

Biceps Curl

FSW40801

KOMPAN[®]



Item no. FSW40801-0001

General Product Information

| | |
|------------------|---|
| Dimensions LxWxH | 86x130x92 cm |
| Age group | 13+ |
| Capacity (users) | 1 |
| Colour options |  |



The Biceps machine provides smooth weight training for the arms. It is incredibly easy to use, as the only required adjustment is the weight load. The ergonomically shaped handles are comfortable and offer multiple grip positions to target the muscles from different angles.

Biceps Curl

FSW40801



All mechanical stops are fully enclosed within the cover. The adjustable weight, featuring internal end stops and indexed positions, moves on rollers within an enclosed groove in an aluminium profile. As a result, entrapment is not possible, making it extremely safe to use and providing protection against the elements and unwanted abuse.



All Steel components are made from carbon steel, with a hot-dip galvanized surface according to ISO1461, and a powder coating corrosion class C3 according to ISO12944-2. Lead content for surfaces is below 90ppm, and below 100ppm for base material.



The machine features low operating noise thanks to an internal end stop made from TPE (thermoplastic elastomer). The damper absorbs impact energy from the weight with minimal rebound, reducing noise and vibration and ensuring a quieter, more controlled training experience.

| Item no. FSW40801-0001 | |
|--------------------------|---------------------|
| Installation Information | |
| Max. fall height | 0 cm |
| Safety surfacing area | 8.2 m ² |
| Total installation time | 0.0 hours |
| Excavation volume | 0.00 m ³ |
| Concrete volume | 0.00 m ³ |
| Footing depth (standard) | 0 cm |
| Shipment weight | 0 kg |
| Anchoring options | |
| Warranty Information | |
| Galvanised/painted metal | 10 years |
| Aluminum | 15 years |
| Movable parts | 2 years |
| Spare parts guaranteed | 10 years |



The ergonomically shaped handles are designed for comfort and feature multiple grip positions to allow targeted training from different angles. The double-hinged design ensures natural wrist movement throughout the exercise, promoting smooth motion and properly loaded biceps engagement.



The weight can be adjusted in 8 steps of 10 lbs, providing a training weight from 15 to 85 lbs. The patent pending system is intuitive to use, eliminating the need for traditional pins that can get lost or stuck. Pull the handle and move the weight to quickly select the desired load.



The information sign is made of Polycarbonate and shows the most relevant exercise and a QR code. The QR code links to a video of the exercise in the KOMPAN sports & fitness App, which will provide a large amount of exercises and training.

Sustainability Data

FSW40801



Independent review certificate

Kompan A/S
C. F. Tietgens Blvd. 32C, 5220 Odense SØ

Bureau Veritas hereby attests that the CO₂e-calculations (covering materials, processing, waste and transport) done by Kompan for "Fitness", meet the requirements set by the listed standard.

Kompan A/S uses a selection of EPDs and emission factors from the Life Cycle Assessment database Ecoinvent 3.11. These values are reported as kg CO₂e, with all other impact categories excluded in line with the scope of ISO 14067:2018. The emission factors cover, material use, manufacturing processes, transport to Kompan, and electricity used during manufacturing. The presented emissions fall under GHG Protocol scope 3 emissions. Scope 1 and 2 are not presented. Scope 3 emissions include emission sources in the upstream value chain of a company, downstream emissions are excluded in this analysis.

Method: ISO 14067:2018 using GHG protocol guidance documents, reported as kg CO₂e.

Object

The verification has been done on the one pager "FAZ10100-0900" version: 27-10-2025. The supporting documentation "KOMPAN data_updated emissions factors_2025_V2" and "Emissions factors, EPD's and ecoinvent 3.11_2025" was also reviewed and approved.

Declaration

The review has been completed as a critical review with a limited assurance. I hereby confirm that nothing has come to the reviewer's attention which would lead to conclude that the study does not give an accurate depiction or isn't completed following method of the CO₂e calculation, the requirements of ISO 14067:2018, and 14071:2024, in the above referenced documentation.

Note: This verification only covers calculation elements according to method described in ISO 14067:2018 and may not be seen as a Life Cycle Assessment according to ISO 14067:2018.

Ref.: Kompan_Verification report 2025, 28-10-2025

Date of certificate: 29-10-2025

Expire date: 29-10-2027

Verified by: Julie Marie Vejsgaard Larsen, Environmental Auditor

Signature:

| Cradle to Gate A1-A3 | Total CO ₂ emission | CO ₂ e/kg | Recycled material |
|----------------------|--------------------------------|-------------------------|-------------------|
| | kg CO ₂ e | kg CO ₂ e/kg | % |
| FSW40801-0001 | 0.00 | 0.00 | 0.00 |

The overall framework applied for these factors is the Environmental Product Declaration (EPD), which quantifies "environmental information on the life cycle of a product and enable comparisons between products fulfilling the same function" (ISO, 2006). This follows the structure and applies a Life-Cycle Assessment approach to the entire Product stage from raw material through manufacturing (A1-A3))

Biceps Curl

FSW40801

* Max fall height | ** Total height | *** Safety surfacing area

* Max fall height | ** Total height

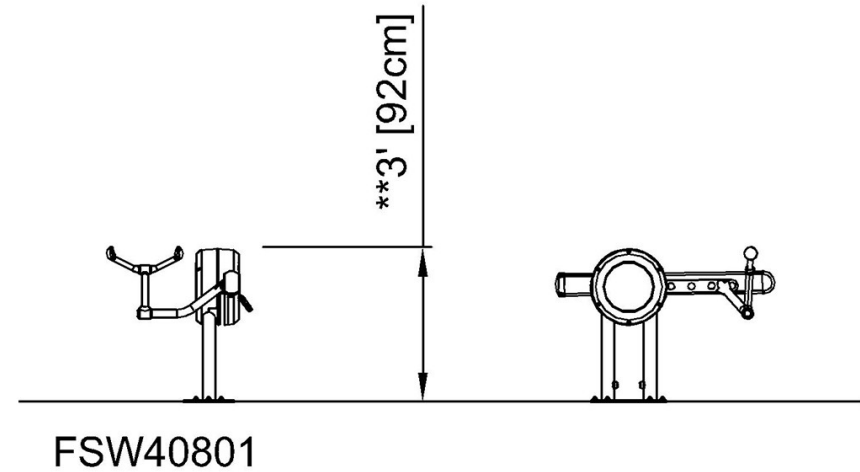
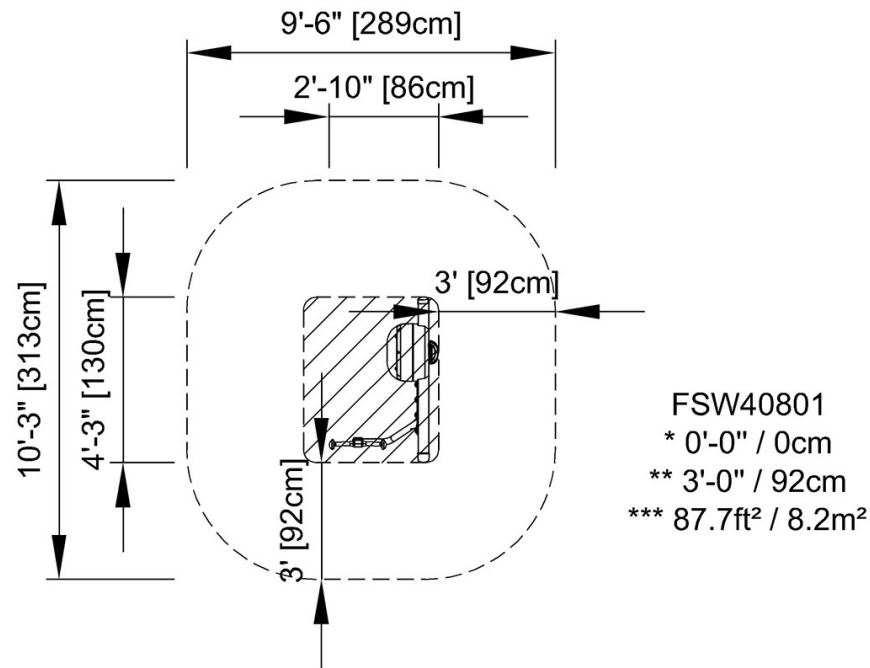

[Click to see TOP VIEW](#)

[Click to see SIDE VIEW](#)