

# Four Towers with Tunnel

PCM400221

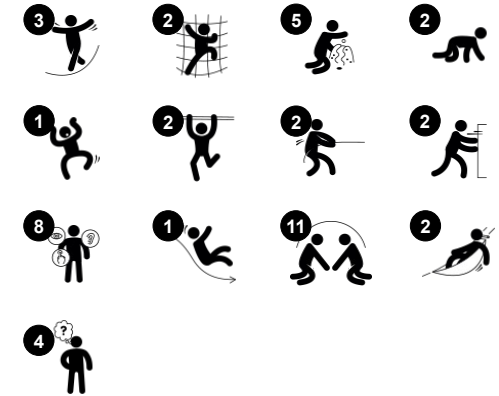

Item no. PCM400221-0603	
General Product Information	
Dimensions LxWxH	489x325x211 cm
Age group	1+
Play capacity (users)	23
Color options	



The Four Towers with Tunnel unit offers a playful social-emotional learning as well as physical growth for toddlers. The unit has a rich variety of play activities, encouraging hours of play. The loop of play between the four towers offers graded play challenges for younger and older toddlers. The slide section allows for high-pace, cardio and balance packed looping,

sliding down and then running back around to slide down again. The balancing and wobble bridges invite stomach tickling balance training. The responses from the moving bridges when other children are also on it are excellent unpredictable challenges for balance. The tunnel encourages crawling, which trains cross-coordination and cross-modal perception,

important for reading. The talking tubes, inviting children to communicate from one side of the tower to the other, making friends and socialising whilst improving their literacy skills.



Data is subject to change without prior notice.

# Four Towers with Tunnel

PCM400221



Panels of 19mm EcoCore™. EcoCore™ is a highly durable, eco friendly material, which is not only recyclable after use, but is also produced from +95% recycled post consumer material from food packing waste. Wooden panels of impregnated and brown painted pine wood with vertical steel profiles.



Main posts with hot dip galvanized steel footing are available in different materials: Pressure impregnated pine wood posts. Pre-galvanized inside and outside with powder coated top finish steel posts. Lead free aluminum with color anodized top finish. Greenline TexMade posts of 95% post-consumer recycled PE and textile waste.

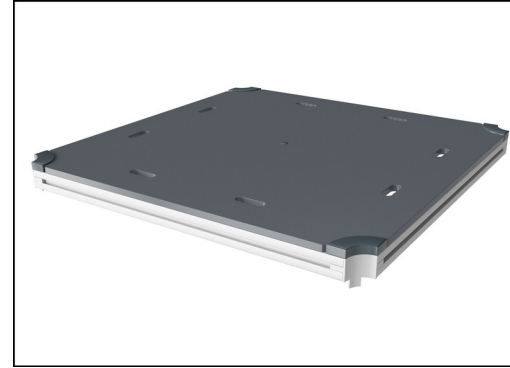

All decks are supported by unique designed low-carbon aluminum profiles with multiple attachment options. The grey colored molded decks are made of 75% post-consumer waste PP material with a non-skid pattern and texture surface.

Item no. PCM400221-0603

### Installation Information

Max. fall height	100 cm
Safety surfacing area	35.7 m <sup>2</sup>
Total installation time	21.1
Excavation volume	0.60 m <sup>3</sup>
Concrete volume	0.00 m <sup>3</sup>
Footing depth (standard)	60 cm
Shipment weight	715 kg
Anchoring options	



Coloured steel components have a base of hot dip galvanisation and a powder coated top finish. This provides an ultimate corrosion resistance in all climates around the world.



The slides can be chosen in six different colors and three materials: Straight or curved one-piece molded PE slides, made from 33% recycled post-consumer materials in different colours. Combined EcoCore™ sides and stainless-steel. Full stainless steel in one piece design for more vandalism proof solutions.



KOMPAN GreenLine versions are designed with ultimate environmentally friendly materials with lowest possible CO2e emission factor. TexMade post, EcoCore™ panels of 95% post-consumer recycled waste and molded PP decks.



# Sustainability Data

PCM400221



Cradle to Gate A1-A3	Total CO <sub>2</sub> emission	CO <sub>2</sub> e/kg	Recycled materials
	kg CO <sub>2</sub> e	kg CO <sub>2</sub> e/kg	%
<b>PCM400221-0651</b>	1,018.10	1.95	61.10
<b>PCM400221-0603</b>	899.00	1.77	28.70

The overall framework applied for these factors is the Environmental Product Declaration (EPD), which quantifies "environmental information on the life cycle of a product and enable comparisons between products fulfilling the same function" (ISO, 2006). This follows the structure and applies a Life-Cycle Assessment approach to the entire Product stage from raw material through manufacturing (A1-A3))

**Kompan A/S**  
 C.F. Tietgens Boulevard 32C  
 DK-5220 Odense SØ  
 Denmark



## Verification of CO<sub>2</sub> calculation of: Play systems



Data version no. 2023-10-05

The CO<sub>2</sub> calculation and data are in compliance with the principles of a carbon footprint impact according to the GHG protocol (Greenhouse Gas Protocol), Scope 3, cradle to gate related to all individual components in the product category: "Play systems" represented by item no.: PCM200321-0950.

(Scope 3 emissions include emission sources in the upstream and downstream value chain).

**Date: 30. October 2023 | Valid until: 30. October 2025**

Verified by:

Julie Marie Vejsgaard Larsen, LCA & EPD Consultant

Verification based on report: Validation of CO<sub>2</sub> calculation of 9 categories of Kompan product line, version 1.0, prepared by: Bureau Veritas HSE, Denmark: Julie M. V. Larsen.

**Publication date: 30. October 2023**

By Bureau Veritas HSE  
 www.bureauveritas.dk  
 +45 7731 1000



# Four Towers with Tunnel

PCM400221

\* Max fall height | \*\* Total height | \*\*\* Safety surfacing area

\* Max fall height | \*\* Total height

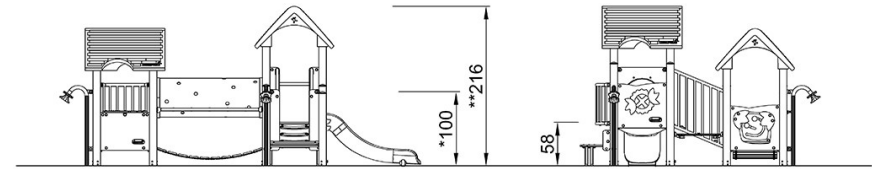
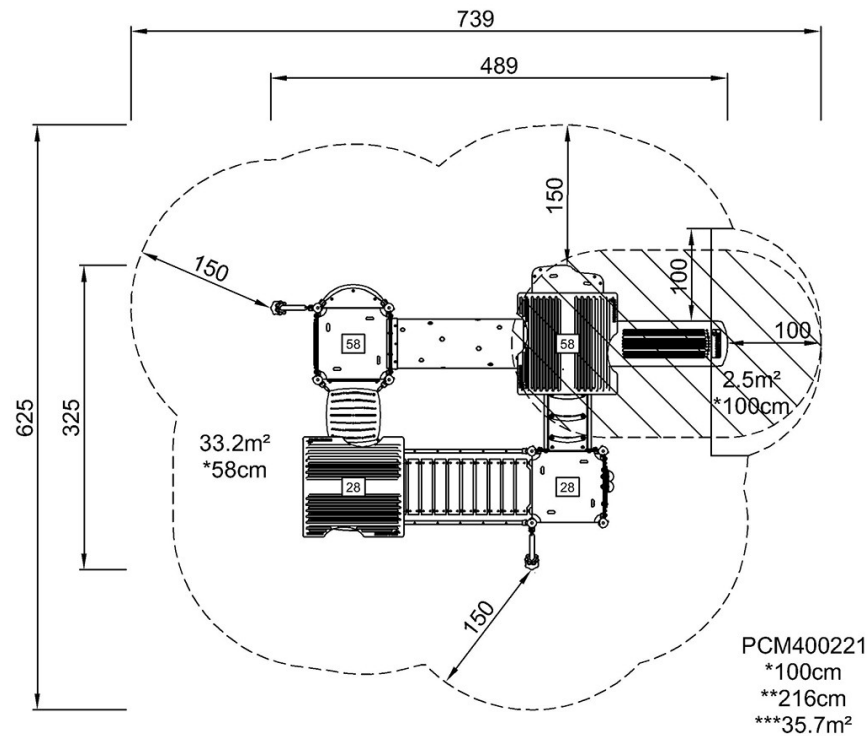

PCM400221

[Click to see TOP VIEW](#)

[Click to see SIDE VIEW](#)