

Racer

ELE400002



Item no. ELE400002-01E

General Product Information

Dimensions LxWxH	71x36x68 cm
Age group	2+
Play capacity (users)	1
Colour options	



The Racer, with its whimsical, rodeo appearance attracts toddlers for a shorter or longer ride, again and again. Apart from its appealing shapes, the Racer offers tactile variation with its rubber handholds and smooth body. Tactile richness is a main motivator, especially in younger children. It supports their understanding of material characteristics such

as weight, texture, temperature, and flexibility. The slightly sloped seat provides a seating destination that ensures hours, years, and decades of fun for many generations. The soothing, rocking movement of the Racer trains the sense of balance and spatial awareness. These are both crucial for body confidence, e.g. fall prevention. A well-developed sense of

balance is fundamental for the ability to sit still and concentrate. The Racer offers children more than just a fun ride.



Data is subject to change without prior notice.

Racer

ELE400002



Handhold

Physical: opens more hold positions and ensures good grip, necessary for rocking intensely which trains hand and arm muscles.



Rocking spring

Physical: response to movements adds to spatial awareness and sense of balance which are fundamental motor skills.

Cognitive: trains the understanding of cause and effect: when I move my body, the spring responds with movement.

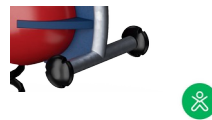

Foot support

Physical: the footrest supports intensive rocking, which stimulates the senses of balance and space, fundamental for managing the world securely.

Racer

ELE400002



The seat is made of recyclable PE and moulded in one piece with a minimum 5mm wall thickness. PE has high impact resistance across a wide temperature span which ensures vandal resistance in all locations.



KOMPAN's springs are manufactured from high-quality spring steel. The springs are cleaned by phosphating before being painted with epoxy primer and polyester powder coating. The springs are fixed by unique anti-pinch fittings for maximum safety and longevity.



The springs are fixed by unique anti-pinch fittings for maximum safety and longevity.

Item no. ELE400002-01E	
Installation Information	
Max. fall height	60 cm
Safety surfacing area	5.9 m ²
Total installation time	1.8
Excavation volume	0.19 m ³
Concrete volume	0.00 m ³
Footing depth (standard)	45 cm
Shipment weight	37 kg
Anchoring options	In-ground ✓ Surface ✓
Warranty Information	
Handle	10 years
Hollow PE parts	10 years
Galvanised Steel	Lifetime
Spare Parts Guarantee	10 years
Springs	5 years



Handles are made with a moulded PP insert and an outer layer of soft TPV rubber. The handles are attached a galvanised steel pipe to ensure strength and durability.



The steel surfaces are hot-dip galvanised inside and outside with lead-free zinc. The galvanisation has excellent corrosion resistance in outside environments and requires low maintenance.



KOMPAN GreenLine versions are designed with ultimate environmentally friendly materials with the lowest possible CO₂e emission factor such as EcoCore™ panels of 100% post consumer recycled ocean waste.



Sustainability Data

ELE400002



Cradle to Gate A1-A3	Total CO ₂ emission	CO ₂ e/kg	Recycled materials
	kg CO ₂ e	kg CO ₂ e/kg	%
ELE400002-01E	81.44	2.53	42.92

The overall framework applied for these factors is the Environmental Product Declaration (EPD), which quantifies "environmental information on the life cycle of a product and enable comparisons between products fulfilling the same function" (ISO, 2006). This follows the structure and applies a Life-Cycle Assessment approach to the entire Product stage from raw material through manufacturing (A1-A3))

Kompan A/S
 C.F. Tietgens Boulevard 32C
 DK-5220 Odense SØ
 Denmark



Verification of CO₂ calculation of: Freestanding play equipment



Data version no. 2023-10-05

The CO₂ calculation and data are in compliance with the principles of a carbon footprint impact according to the GHG protocol (Greenhouse Gas Protocol), Scope 3, cradle to gate related to all individual components in the product category: "Freestanding play equipment" represented by item no.: GXY916012-3417.

(Scope 3 emissions include emission sources in the upstream and downstream value chain).

Date: 30. October 2023 | Valid until: 30. October 2025

Verified by:

Julie Marie Vejsgaard Larsen, LCA & EPD Consultant

Verification based on report: Validation of CO₂ calculation of 9 categories of Kompan product line, version 1.0, prepared by: Bureau Veritas HSE, Denmark: Julie M. V. Larsen.

Publication date: 30. October 2023

By Bureau Veritas HSE
 www.bureauveritas.dk
 +45 7731 1000



Racer

ELE400002

* Max fall height | ** Total height | *** Safety surfacing area

* Max fall height | ** Total height

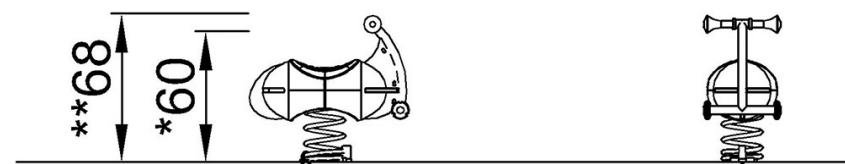
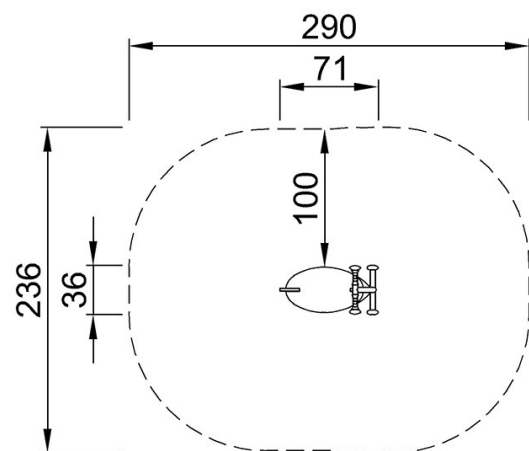

ELE400002

ELE400002

*60cm

**68cm

***5.9m²

[Click to see TOP VIEW](#)

[Click to see SIDE VIEW](#)