

Boogie Spinner™

ELE400068

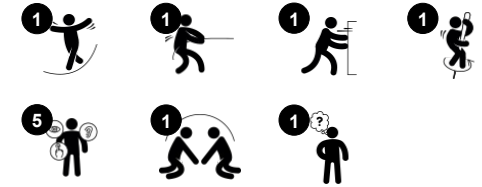

Item no. ELE400068-3217RE	
General Product Information	
Dimensions LxWxH	123x124x129 cm
Age group	6+
Play capacity (users)	4
Colour options	



The whimsical shape and great fun of the Boogie Spinner attracts children again and again. The novel movements, a tilting effect in combination with rotation, evoke children's sense of wonder and are endlessly fun. Responsive to the children's movements, it spins when pushed and pulled, training arms and leg muscles. When holding tight to the

handle children train their core muscles and arm muscles. The rotating movement trains the sense of space and balance, which is fundamental for all other motor skills and motor control. The Boogie Spinner's roomy platform encourages social interaction with fun negotiation, turn-taking, and cooperation. The Boogie Spinner facilitates thrilling play and

social play.



Boogie Spinner™

ELE400068

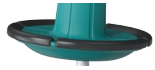

Curved platform

Physical: trains the sense of balance and space as well as the children's upper and lower body muscle strength and bone density when they hold tight or jump on and off.

Social-Emotional: the horizontal surface allows for more children playing and sharing, training cooperation and negotiation skills as well as building up self-confidence and empathy.



Handhold

Physical: the vertical handgrips ensure a firm grip at different heights, necessary for rocking intensely. This trains hand and arm muscles.



Tilting

Physical: coordination and balance are supported when spinning. Leg, core and arms are trained when pushing, pulling or coordinating the Boogie Spinner into motion. When jumping on and off, bone density is strengthened. Bone density for life is mainly built up during childhood. **Social-Emotional:** cooperation, consideration and turn-taking. **Cognitive:** logical thinking, figuring out how to make rotation, speeding up or slowing down the spin.

Boogie Spinner™

ELE400068



The Boogie Spinner is mounted with a double bearing meaning that it can move from side to side while spinning, creating an extra challenge. To ensure safety, the Spinner is equipped with a 360-degree metal handle on top, as well as a non-slip standing surface.



Kompan has designed the Boogie Spinner with a soft, shock absorbent 360-degree bumper with non-slip surface makes the Spinner safe and extremely user friendly.



The central part of the Boogie Spinner is made of recyclable polyethylene (PE) made from 33% post consumer materials and is rotomolded in one piece with integrated metal thread bushings and water drain holes to ensure high durability in all climates around the world.

Item no. ELE400068-3217RE	
Installation Information	
Max. fall height	100 cm
Safety surfacing area	25.0 m ²
Total installation time	2.8
Excavation volume	0.44 m ³
Concrete volume	0.25 m ³
Footing depth (standard)	90 cm
Shipment weight	226 kg
Anchoring options	In-ground ✓ Surface ✓
Warranty Information	
Hollow PE parts	10 years
Hot dip galvanised steel	Lifetime
Movable parts	2 years
Spare parts guaranteed	10 years

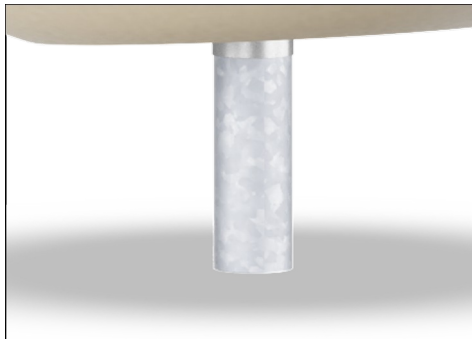

The steel surfaces are hot dip galvanized inside and outside with lead free zinc. The galvanization has excellent corrosion resistance in outside environments and requires low maintenance.



Heavy duty engineered bearing system with single row deep groove ball bearings with rubber seals. The fully closed bearing construction is lifetime lubricated and maintenance free.



The Boogie Spinner will be available in five different Kompan colours which are Red, Green, Blue, Beige and Teal.

EN
1176
compliant

Sustainability Data

ELE400068



Cradle to Gate A1-A3	Total CO ₂ emission	CO ₂ e/kg	Recycled materials
	kg CO ₂ e	kg CO ₂ e/kg	%
ELE400068-3217RE	253.22	2.65	42.84

The overall framework applied for these factors is the Environmental Product Declaration (EPD), which quantifies "environmental information on the life cycle of a product and enable comparisons between products fulfilling the same function" (ISO, 2006). This follows the structure and applies a Life-Cycle Assessment approach to the entire Product stage from raw material through manufacturing (A1-A3))

Kompan A/S
C.F. Tietgens Boulevard 32C
DK-5220 Odense SØ
Denmark



Verification of CO₂ calculation of: Freestanding play equipment



Data version no. 2023-10-05

The CO₂ calculation and data are in compliance with the principles of a carbon footprint impact according to the GHG protocol (Greenhouse Gas Protocol), Scope 3, cradle to gate related to all individual components in the product category: "Freestanding play equipment" represented by item no.: GXY916012-3417.

(Scope 3 emissions include emission sources in the upstream and downstream value chain).

Date: 30. October 2023 | Valid until: 30. October 2025

Verified by:

Julie Marie Vejsgaard Larsen, LCA & EPD Consultant

Verification based on report: Validation of CO₂ calculation of 9 categories of Kompan product line, version 1.0, prepared by: Bureau Veritas HSE, Denmark: Julie M. V. Larsen.

Publication date: 30. October 2023

By Bureau Veritas HSE
www.bureauveritas.dk
+45 7731 1000



Boogie Spinner™

ELE400068

* Max fall height | ** Total height | *** Safety surfacing area

* Max fall height | ** Total height

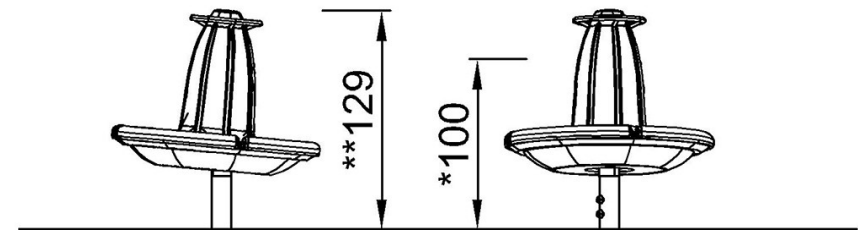
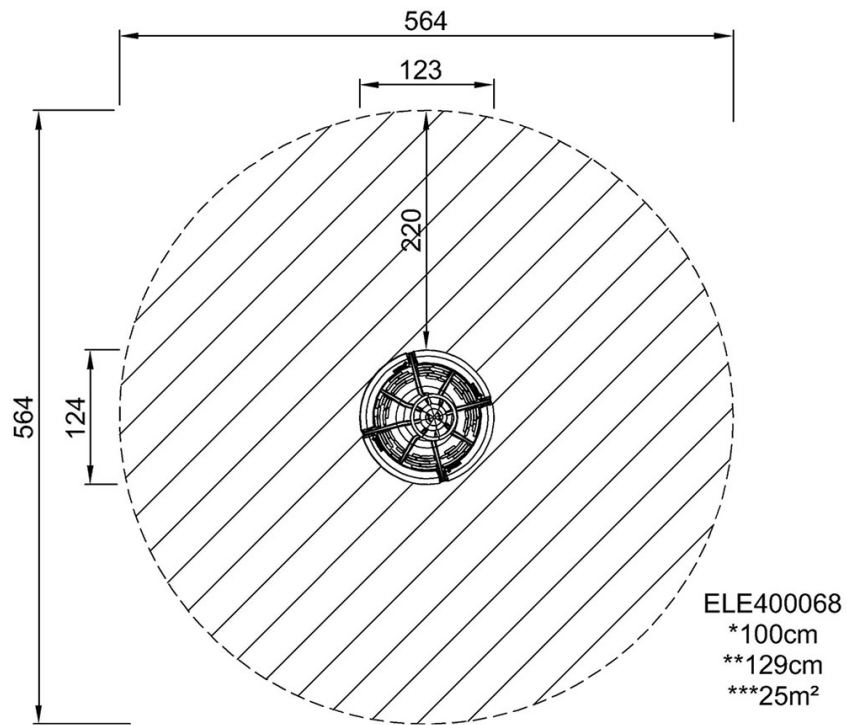

ELE400068

[Click to see TOP VIEW](#)

[Click to see SIDE VIEW](#)