

Super Combi 1, Supervised

FSW251

KOMPAN
Let's play



Produktnummer FSW25100-0900

Allgemeine Produktinformation

Maße L x B x H	533x550x325 cm
Empfohlenes Alter	13+
Spielkapazität (Nutzer)	13
Farbauswahl	



The Super Combi 1 Gated has the same options as the standard Super Combi 1 but also has a connector for battle rope, a connector for a boxing bag, and a station for barbell exercises. This item is intended for supervised or gated areas such as sports or fitness clubs, as these loose items do not satisfy safety standards for public

places.
Supervised products are only for areas that are gated or fenced-off, like fitness clubs with supervision or gated communities.



Super Combi 1, Supervised

FSW251



Die Pfosten sind aus \varnothing 101,6 x 2 mm, aus vorverzinktem Baustahl gefertigt und pulverbeschichtet, ein hervorragender Schutz bei allen Wetterbedingungen.



Produktnummer FSW25100-0900

Montage-Information

Max. freie Fallhöhe	200 cm
Fläche des Fallraums	46,3 m ²
Gesamt-Montagezeit	11,5
Erforderlicher Erdaushub	0,83 m ³
Betonbedarf	0,50 m ³
Fundamenttiefe (Standard)	90 cm
Versandgewicht	609 kg
Verankerungsoptionen	TV ✓ OFM ✓

Garantie-Information

EcoCore HDPE	Lebenslang
Verzinkter Stahl	Lebenslang
PUR Bestandteile	10 Jahre
Ersatzteilgarantie	10 Jahre
Stahl	10 Jahre

Umweltdaten

FSW251



Von der Wiege bis zum Werkstor („cradle to gate“) (A1–A3)

CO ₂ -Emissionen gesamt	CO ₂ e pro kg	Recycelte Materialien	
kg CO ₂ e	kg CO ₂ e pro kg	%	
FSW25100-0900	948,55	2,41	56,70

Den allgemeinen Rahmen für diese Faktoren bilden die Umweltproduktdeklarationen (EPDs). Mithilfe dieser Grundregeln können die Umweltinformationen über den Lebenszyklus eines Produkts hinweg quantifiziert und Vergleiche zwischen Produkten, die dieselbe Funktion erfüllen, angestellt werden (vgl. ISO, 2006). Diese Struktur wird hier befolgt. Der Ansatz zur Lebenszyklusbewertung wird dabei auf die gesamte Herstellungsphase – vom Rohstoff bis zur Herstellung (A1–A3) – angewendet.

Kompan A/S
C.F. Tietgens Boulevard 32C
DK-5220 Odense SØ
Denmark



Verification of CO₂ calculation of:
Fitness



Data version no. 2023-10-05

The CO₂ calculation and data are in compliance with the principles of a carbon footprint impact according to the GHG protocol (Greenhouse Gas Protocol), Scope 3, cradle to gate related to all individual components in the product category: "Fitness" represented by item no.: FAZ10100-0900.

(Scope 3 emissions include emission sources in the upstream and downstream value chain).

Date: 30. October 2023 | Valid until: 30. October 2025

Verified by:

Julie Marie Vejsgaard Larsen, LCA & EPD Consultant

Verification based on report: Validation of CO₂ calculation of 9 categories of Kompan product line, version 1.0, prepared by: Bureau Veritas HSE, Denmark: Julie M. V. Larsen.

Publication date: 30. October 2023

By Bureau Veritas HSE
www.bureauveritas.dk
+45 7731 1000



Super Combi 1, Supervised

FSW251

* Max freie Fallhöhe | ** Gesamthöhe | *** Fläche des Fallraums

* Max freie Fallhöhe | ** Gesamthöhe

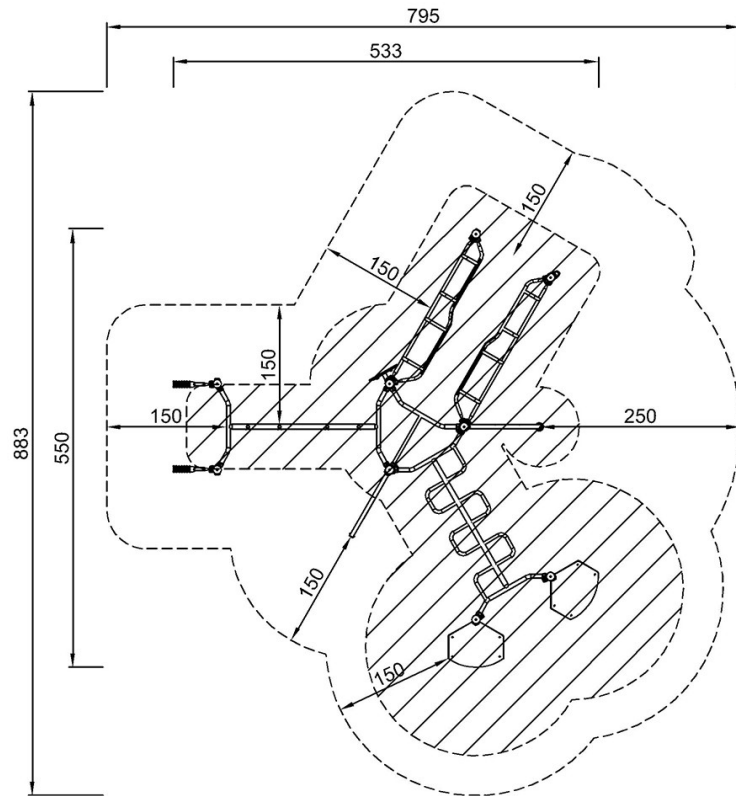

FSW25100
*200cm
**325cm
***46.3m²

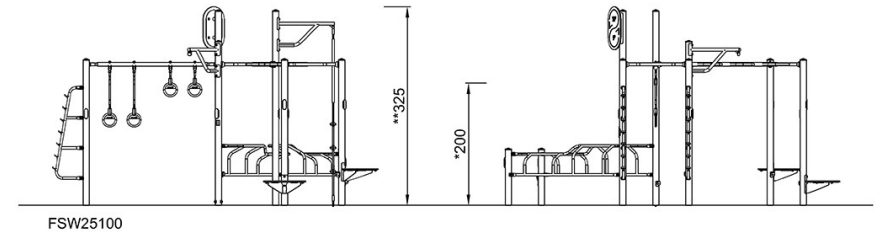

[Klicken Sie hier, um die DRAUFSICHT anzuzeigen](#)

[Klicken Sie hier, um die SEITENANSICHT anzuzeigen](#)