

Cocowave Rope Pendulum Swing

NRO915

KOMPANI
Let's play



Item no. NRO915-1001

General Product Information

Dimensions LxWxH	18'6"x10'9"x12'9"
Age group	5 - 12
Play capacity (users)	8
Color options	

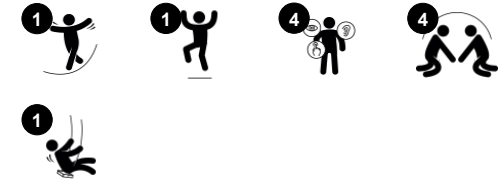

The size and appearance of the Robinia Cocowave Pendulum Swing is an irresistible invitation for all children to play. With its robust, oblong coconut rope, the Robinia Cocowave Pendulum Swing allows for swinging from a seated, lying or standing position. The thrill of swinging – mildly or wildly – is for bigger groups, of different sizes, ages and physical

abilities. It takes teamwork to make the swing move, and this stimulates important social-emotional skills. Apart from being fun, swinging on the Cocowave swing also trains muscles and important motor skills, such as balance, coordination and sense of space. These are important to train vestibular skills that matter profoundly for many real life situations,

including navigating traffic safely. The exciting, challenging feeling of speed and height stimulates children's self-esteem, risk management and other important social-emotional life skills.

Cocowave Rope Pendulum Swing

NRO915



Chains

Physical: space between chains supports a comfortable grip for use of muscle strength when standing up swinging.



Connectors in the side of the rope

Physical: allow for foot position between connectors resulting in ease of use when standing up swinging. Develops muscle strength. **Social-Emotional:** room for different body positions like standing, sitting and lying.



Cocowave swing

Physical: supports muscle strength, sense of balance and space. Bone density is built up when children swing and jump on-off. **Social-Emotional:** height and speed of swinging supports self-esteem. When listening and negotiating, children develop their empathy and cooperation skills. **Cognitive:** height and speed of swinging helps children to judge distances and heights.



Coconut rope

Physical: balance and coordination is supported when walking the swaying rope. A good sense of balance transfers to other skills such as sitting still on a chair. Bone density is developed when jumping off. **Social-Emotional:** children swaying together on the rope experience their own and others' movements. This spurs cooperation and consideration, e.g. when passing others on the rope.

Cocowave Rope Pendulum Swing

NRO915



All Organic Robinia products by KOMPAN are made of Robinia wood from sustainable European sources. On request it can be supplied as FSC® Certified (FSC® C004450).



The paint used for colored components is water based environmental friendly with excellent UV resistance. The paint is in compliance with EN 71 Part 3.



Unique designed swing hangers of stainless steel with anti-twist function. The hangers are attached to the cross beam by a bolt through connection to ensure high durability.



The rope of the pendulum swing is made of polypropylene (PP) rope in Coconut style with a square shape of 14x14cm. The ends of the Coconut rope are closed by a steel clamps and sealed by a glued-on shrinkable tubing. The last 10cm of the rope ends are cut open to make a tassel with bumper function to fulfill global safety requirements.



The chain/ropes are attached to the Coconut rope by KOMPAN swivel bushings made of stainless steel with bronze bearings. The swivels have an outside cover of black PUR. The usage of side mounted swivels provides frictionless movement, eliminates fingers and feet entrapments and enlarges the standing surface on top of the rope.

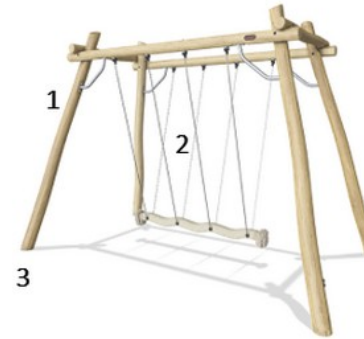

The Cocowave pendulum swing is available in multiple options: untreated Robinia wood, brown pigmented or green colored version, rope or stainless steel chain suspensions, wood in-ground or steel footings.

Item no. NRO915-1001	
Installation Information	
Max. fall height	10'10"
Safety surfacing area	732ft ²
Total installation time	14.4
Excavation volume	3.66yd ³
Concrete volume	2.2yd ³
Footing depth (standard)	3'3"
Shipment weight	1592lbs
Anchoring options	In-ground ✓
Warranty Information	
Chains	10 Years
Movable parts	2 Years
Robinia Wood	10 Years
Ropes & nets	10 Years
Spare Parts Availability	10 Years

Elevated activities 8	Accessible elevated activities	Accessible ground level activities	Accessible ground level play types
Present	0	1	1
Required	0	1	1



Sustainability Data

NRO915



Cradle to Gate A1-A3	Total CO ₂ emission	CO ₂ e/kg	Recycled materials
	kg CO ₂ e	kg CO ₂ e/kg	%
NRO915-1001	535.98	0.85	6.53

The overall framework applied for these factors is the Environmental Product Declaration (EPD), which quantifies "environmental information on the life cycle of a product and enable comparisons between products fulfilling the same function" (ISO, 2006). This follows the structure and applies a Life-Cycle Assessment approach to the entire Product stage from raw material through manufacturing (A1-A3))

Kompan A/S
 C.F. Tietgens Boulevard 32C
 DK-5220 Odense SØ
 Denmark



Verification of CO₂ calculation of: Nature play



Data version no. 2023-10-05

The CO₂ calculation and data are in compliance with the principles of a carbon footprint impact according to the GHG protocol (Greenhouse Gas Protocol), Scope 3, cradle to gate related to all individual components in the product category: "Nature play" represented by item no.: NRO409-0621.

(Scope 3 emissions include emission sources in the upstream and downstream value chain).

Date: 30. October 2023 | Valid until: 30. October 2025

Verified by:

Julie Marie Vejsgaard Larsen, LCA & EPD Consultant

Verification based on report: Validation of CO₂ calculation of 9 categories of Kompan product line, version 1.0, prepared by: Bureau Veritas HSE, Denmark: Julie M. V. Larsen.

Publication date: 30. October 2023

By Bureau Veritas HSE
 www.bureauveritas.dk
 +45 7731 1000



Cocowave Rope Pendulum Swing

NRO915

* Max fall height | ** Total height | *** Safety surfacing area

* Max fall height | ** Total height

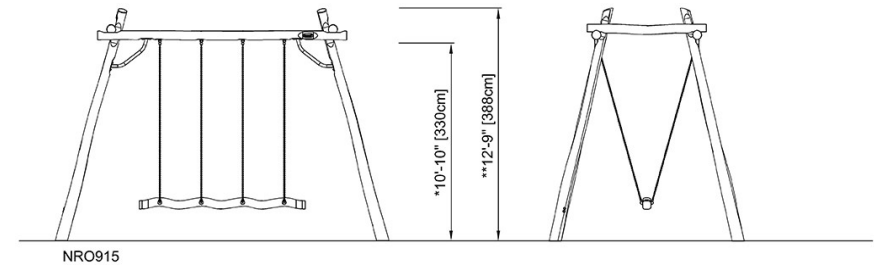
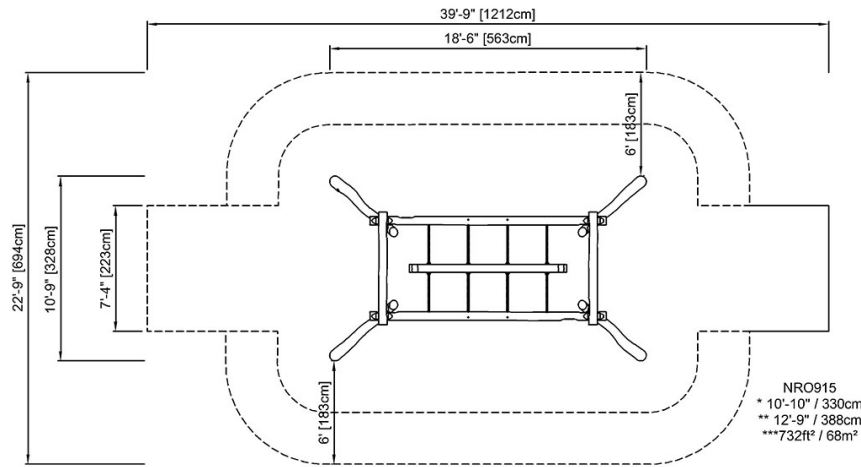

[Click to see TOP VIEW](#)

[Click to see SIDE VIEW](#)