

Robinia Embankment Slide

NRO310

KOMPAN
Let's play



Item no.	
General Product Information	
Dimensions LxWxH	189x424x133 cm
Age group	4+
Play capacity (users)	2
Colour options	



The curved embankment slide motivates fun for all children and those childish at heart. Due to the embankment run loop, children will run up and slide down again and again. Sliding on the embankment slide is a great fun experience as friends can run up or down next to the sliding child. There is room for many children and for different ages and abilities to play together. The

embankment hill is a great place for rolling or running too. When children slide they train their core muscles, sitting upright while sliding down. This stimulates their trunk stability, important for avoiding back and neck pains – a growing problem in children due to sedentary lifestyles. Running uphill or downhill they can train their balance and coordination as well as their

muscle strength. They can train risk taking in holding back or letting go downhill.

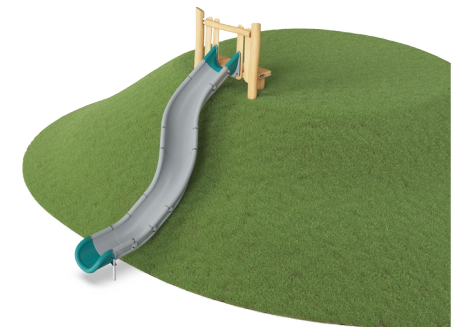

Robinia Embankment Slide

NRO310



Curved slide

Physical: sliding develops spatial awareness and a sense of balance. Furthermore, the core muscles are trained when sitting upright going down. **Social-Emotional:** empathy stimulated by turn-taking.



Robinia Embankment Slide

NRO310



All Organic Robinia products by KOMPAN are made of Robinia wood from sustainable European sources. On request it can be supplied as FSC® Certified (FSC® C004450).



The Robinia wood can be supplied as untreated raw wood or painted with a brown coloured transparent pigment that maintains the golden wood colour of the wood.



Slide interface panel of 19mm EcoCore™. EcoCore™ is a highly durable, eco-friendly material, which is not only recyclable after use, but is also made of +95% recycled post-consumer material from e.g., food packing waste in both core and colorful outer layer.



The slides can be chosen in six different colors and two materials: Molded PE slides made with 33% post consumer materials or full stainless steel in one-piece design for more vandalism proof solutions.

Item no.	
Installation Information	
Max. fall height	38 cm
Safety surfacing area	24.2 m ²
Total installation time	
Excavation volume	
Concrete volume	
Footing depth (standard)	
Shipment weight	
Anchoring options	In-ground ✓
Warranty Information	
EcoCore HDPE	Lifetime
PE slide	10 years
Robinia wood	15 years
Spare parts guaranteed	10 years
Stainless steel components	Lifetime

EN
1176
compliant

Sustainability Data

NRO310



Cradle to Gate A1-A3	Total CO ₂ emission	CO ₂ e/kg	Recycled materials
	kg CO ₂ e	kg CO ₂ e/kg	%

The overall framework applied for these factors is the Environmental Product Declaration (EPD), which quantifies "environmental information on the life cycle of a product and enable comparisons between products fulfilling the same function" (ISO, 2006). This follows the structure and applies a Life-Cycle Assessment approach to the entire Product stage from raw material through manufacturing (A1-A3))

Kompan A/S
 C.F. Tietgens Boulevard 32C
 DK-5220 Odense SØ
 Denmark



Verification of CO₂ calculation of: Nature play



Data version no. 2023-10-05

The CO₂ calculation and data are in compliance with the principles of a carbon footprint impact according to the GHG protocol (Greenhouse Gas Protocol), Scope 3, cradle to gate related to all individual components in the product category: "Nature play" represented by item no.: NRO409-0621.

(Scope 3 emissions include emission sources in the upstream and downstream value chain).

Date: 30. October 2023 | Valid until: 30. October 2025

Verified by:

Julie Marie Vejsgaard Larsen, LCA & EPD Consultant

Verification based on report: Validation of CO₂ calculation of 9 categories of Kompan product line, version 1.0, prepared by: Bureau Veritas HSE, Denmark: Julie M. V. Larsen.

Publication date: 30. October 2023

By Bureau Veritas HSE
 www.bureauveritas.dk
 +45 7731 1000



Robinia Embankment Slide

NRO310

* Max fall height | ** Total height | *** Safety surfacing area

* Max fall height | ** Total height

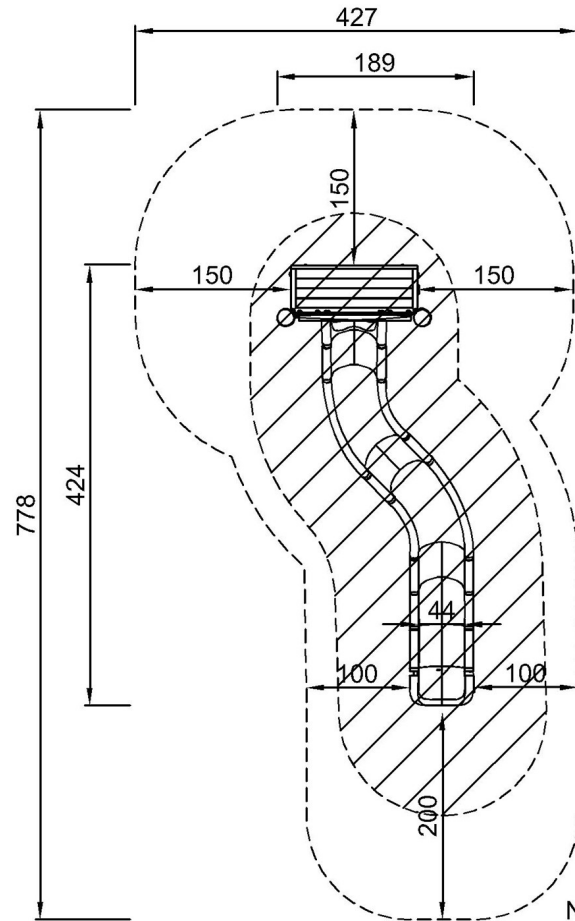

NRO310
*100cm
**133cm
***24.2m²

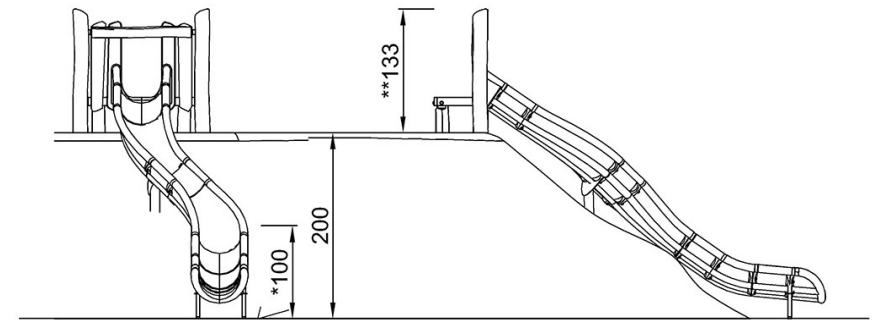

NRO310

[Click to see TOP VIEW](#)

[Click to see SIDE VIEW](#)