

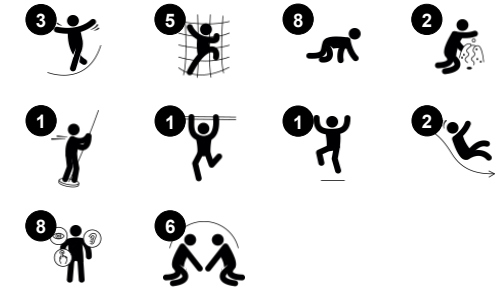

Item no. PCE105321-0903	
General Product Information	
Dimensions LxWxH	330x584x414 cm
Age group	2+
Play capacity (users)	17
Colour options	● ● ●



Wow! The Inventor is a fantastic play structure to support active toddlers. With fun play on all sides, longer playtimes is supported, again and again. The double slide and fireman's pole in each their way support balance and spatial awareness. The twisted stair and the green climbing wall allow access in intriguing ways, training spatial understanding. The climbing net

is especially attractive for children building their climbing skills, thanks to the horizontal and vertical climbers and the red destination balance and climb-through points. The Inventor encourages social-emotional play with plenty of room upstairs and downstairs for many to play. The panel invites play across the Inventor and stimulates cognitive play with its suggestive

symbols. The double slide allows play side by side, making room for caregivers, too. This Inventor invites active play for all areas of development.



Inventor

PCE105321

KOMPANI
Let's play



Double slide

Physical: sliding develops spatial awareness and a sense of balance. Furthermore, the core muscles are trained when sitting upright going down. **Social-Emotional:** invites socializing, supports parent-child and peer-to-peer play. **Cognitive:** young children train their understanding of space, speed and distances when sliding down quickly.



Faces panel

Social-Emotional: spurs group play and conversations with its two-sidedness. **Cognitive:** stimulates theory of mind: that others may have different feelings. Stimulates the understanding of symbols and facial expressions as symbols for emotions. **Creative:** the pointer can be placed in different directions to create stories or change main point of attraction.



Fireman's pole

Physical: coordination is supported when going down, as well as arm and core muscles. Landing strengthens bone density, which is built for life in early childhood. **Social-Emotional:** turn-taking and risk-taking. **Cognitive:** young children develop their understanding of space, speed and distances when gliding down fast.



Climbing net twist

Physical: cross coordination and muscle strength when climbing and crawling through the net. Sense of balance when swaying on red plate. **Social-Emotional:** breaks are invited on the horizontal parts of the twisted net, allowing for socializing. **Cognitive:** figuring out how to position body to climb the twisted net.



Climbing cleat

Physical: placed to support hands and feet when crawling across, they train dexterity, hand and foot strength. **Social-Emotional:** adds the feeling of security, helping children to feel confident in climbing higher.



Wall climber

Physical: crawling up supports cross coordination and trains major muscle groups.



The Curved ELEMENTS panels are moulded of UV stabilised recyclable PE using 33% post-consumer recycled material. With multiple options for in-build play features that also ensures a strong panel solution. Straight panels are made of KOMPAN 19mm HDPE EcoCore™ which is a highly durable, ecofriendly and recyclable material made from +95% PCM.

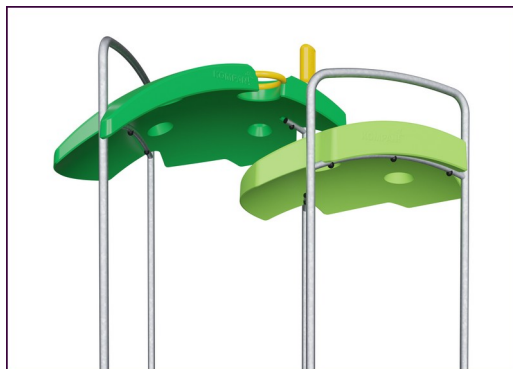

The ELEMENTS roofs are made of recyclable PE made from 33% post consumer recycled materials with a minimum wall thickness of 5 mm to ensure high durability in all climates around the world. The steel pipes are hot dip galvanised inside and outside for maximum durability.



ELEMENTS products are available in three different colour combinations: classic blue & green, blossom orange & yellow, nature lime and green.



The main posts are made of high quality pregalvanized steel with powder coated top finish. Post tops are closed with caps of UV stabilized nylon (PA6). The grey colored molded decks are made of 75% post-consumer waste PP material with a non-skid pattern and texture surface. All decks are supported by unique designed low-carbon aluminum profiles with multiple attachment options.

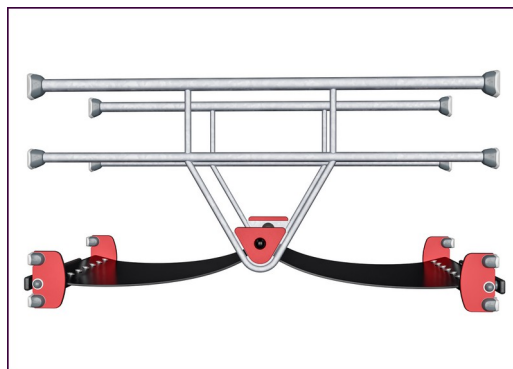

ELEMENTS rubber membranes are conveyor belt made of layers of rubber mixed of natural rubber and SBR rubber, and embedded with layers of armouring made of woven PE and PA. The thickness 8mm ensures high durability in any environment.

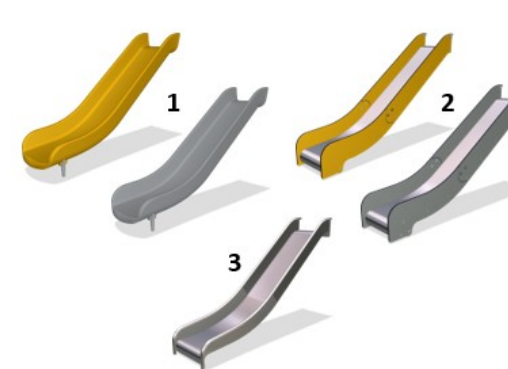

The slides are available in either molded PE made from 33% recycled post-consumer materials in different colors or in full AISI304 stainless steel with a thickness of 2mm.

Item no. PCE105321-0903

Installation Information

Max. fall height	166 cm
Safety surfacing area	37.0 m ²
Total installation time	18.0
Excavation volume	0.41 m ³
Concrete volume	0.06 m ³
Footing depth (standard)	85 cm
Shipment weight	570 kg
Anchoring options	Surface ✓ In-ground ✓

Warranty Information

EcoCore HDPE	Lifetime
Post	10 years
PP Decks	10 years
Ropes & nets	10 years
Spare parts guaranteed	10 years



Sustainability Data

PCE105321



Cradle to Gate A1-A3	Total CO ₂ emission	CO ₂ e/kg	Recycled materials
	kg CO ₂ e	kg CO ₂ e/kg	%
PCE105321-0903	1,309.65	2.98	44.97

The overall framework applied for these factors is the Environmental Product Declaration (EPD), which quantifies "environmental information on the life cycle of a product and enable comparisons between products fulfilling the same function" (ISO, 2006). This follows the structure and applies a Life-Cycle Assessment approach to the entire Product stage from raw material through manufacturing (A1-A3))

Kompan A/S
 C.F. Tietgens Boulevard 32C
 DK-5220 Odense SØ
 Denmark



Verification of CO₂ calculation of: Play systems



Data version no. 2023-10-05

The CO₂ calculation and data are in compliance with the principles of a carbon footprint impact according to the GHG protocol (Greenhouse Gas Protocol), Scope 3, cradle to gate related to all individual components in the product category: "Play systems" represented by item no.: PCM200321-0950.

(Scope 3 emissions include emission sources in the upstream and downstream value chain).

Date: 30. October 2023 | Valid until: 30. October 2025

Verified by:

Julie Marie Vejsgaard Larsen, LCA & EPD Consultant

Verification based on report: Validation of CO₂ calculation of 9 categories of Kompan product line, version 1.0, prepared by: Bureau Veritas HSE, Denmark: Julie M. V. Larsen.

Publication date: 30. October 2023

By Bureau Veritas HSE
 www.bureauveritas.dk
 +45 7731 1000



* Max fall height | ** Total height | *** Safety surfacing area

* Max fall height | ** Total height

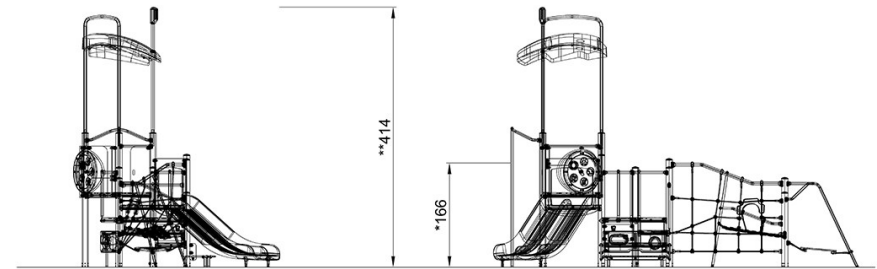
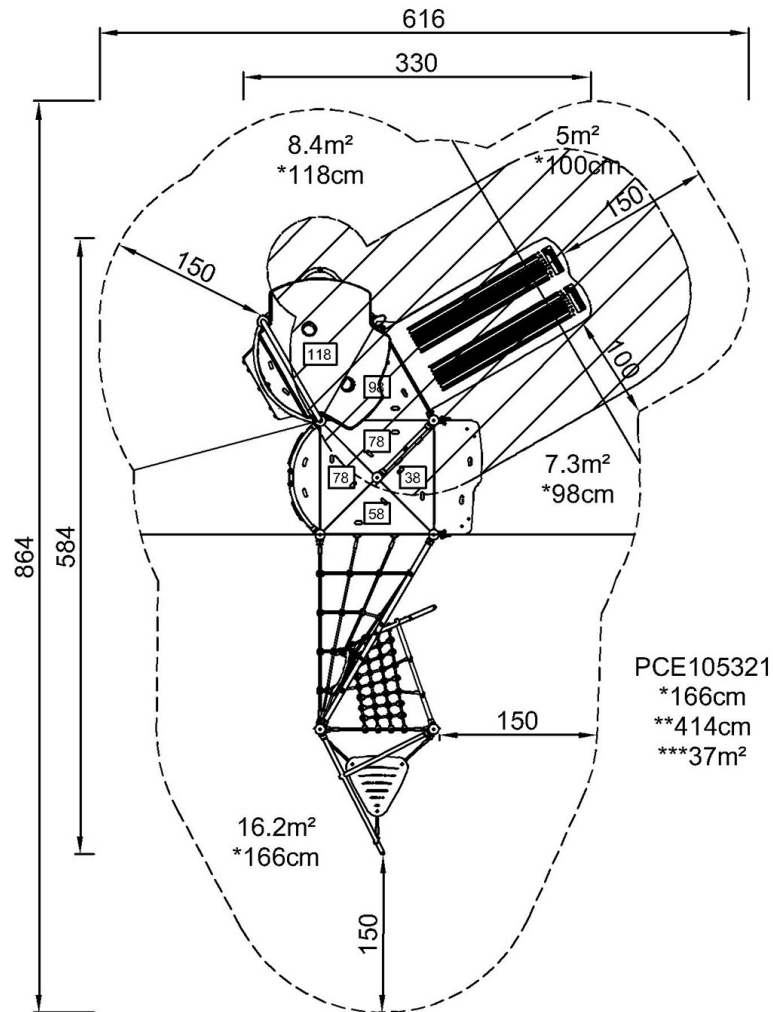

PCE105321

[Click to see TOP VIEW](#)

[Click to see SIDE VIEW](#)