

# Dip Bench Robinia

FRO202



Item no. FRO20200-1001

## General Product Information

Dimensions LxWxH	234x60x73 cm
Age group	13+
Play capacity (users)	2
Colour options	



See KOMPAN Fit app for more



A row of parallel handlebars is suitable for the more advanced hand balancing exercises such as handstand push-ups. Also perfect for dips, an ideal exercise for strengthening the chest, shoulder, and arm muscles. Rounded corners make it safe and simple for anyone to try exercises in which they try to swing their legs over the bar. The Dip Bench has a clear

instruction sign showing the basic exercise and a QR code. By using the QR code users can connect to the KOMPAN fitness App, where they will find multiple exercises and workouts at every level.

The Robinia bars are made from de-barked and sap-free Robinia trunks in various dimensions. Robinia is a native European

wood species with high strength and natural durability in various climatic conditions. KOMPAN uses wood from FSC-certified sources.

# Dip Bench Robinia

FRO202



All Organic Robinia products by KOMPAN are made of Robinia wood from sustainable European sources. On request it can be supplied as FSC® Certified (FSC® C004450).



The Robinia wood can be supplied as untreated raw wood or painted with a brown coloured transparent pigment that maintains the golden wood colour of the wood.



Bars intended as grips during exercises are made of hot-dip galvanised steel ø38mm. A great diameter to support the wrist when doing dips or handstands.

Item no. FRO20200-1001

### Installation Information

Max. fall height	73 cm
Safety surfacing area	11.6 m <sup>2</sup>
Total installation time	3.6
Excavation volume	0.28 m <sup>3</sup>
Concrete volume	0.00 m <sup>3</sup>
Footing depth (standard)	100 cm
Shipment weight	197 kg
Anchoring options	In-ground ✓ Surface ✓

### Warranty Information

Hot dip galvanised steel	Lifetime
Robinia wood	15 years
Spare parts guaranteed	10 years



All KOMPAN fitness products are compliant with the ASTM F3101 & EN16630 Outdoor Fitness Standards. Load tests are performed as a static test by adding dynamic factors as well as safety factors to the specified load of 78kg per user. A product intended for 1 user is loaded with 420kg.

**ASTM  
F3101**  
compliant

# Sustainability Data

FRO202

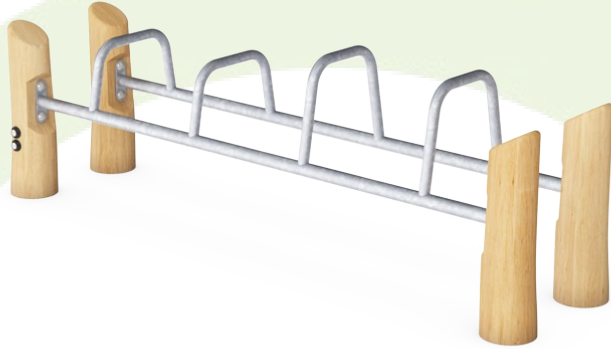

Cradle to Gate A1-A3	Total CO <sub>2</sub> emission	CO <sub>2</sub> e/kg	Recycled materials
	kg CO <sub>2</sub> e	kg CO <sub>2</sub> e/kg	%
<b>FRO20200-1001</b>	80.93	0.55	8.78

The overall framework applied for these factors is the Environmental Product Declaration (EPD), which quantifies "environmental information on the life cycle of a product and enable comparisons between products fulfilling the same function" (ISO, 2006). This follows the structure and applies a Life-Cycle Assessment approach to the entire Product stage from raw material through manufacturing (A1-A3))

**Kompan A/S**  
 C.F. Tietgens Boulevard 32C  
 DK-5220 Odense SØ  
 Denmark



## Verification of CO<sub>2</sub> calculation of: Fitness



Data version no. 2023-10-05

The CO<sub>2</sub> calculation and data are in compliance with the principles of a carbon footprint impact according to the GHG protocol (Greenhouse Gas Protocol), Scope 3, cradle to gate related to all individual components in the product category: "Fitness" represented by item no.: FAZ10100-0900.

(Scope 3 emissions include emission sources in the upstream and downstream value chain).

**Date: 30. October 2023 | Valid until: 30. October 2025**

Verified by:

Julie Marie Vejsgaard Larsen, LCA & EPD Consultant

Verification based on report: Validation of CO<sub>2</sub> calculation of 9 categories of Kompan product line, version 1.0, prepared by: Bureau Veritas HSE, Denmark: Julie M. V. Larsen.

**Publication date: 30. October 2023**

By Bureau Veritas HSE  
 www.bureauveritas.dk  
 +45 7731 1000



# Dip Bench Robinia

FRO202

\* Max fall height | \*\* Total height | \*\*\* Safety surfacing area

\* Max fall height | \*\* Total height

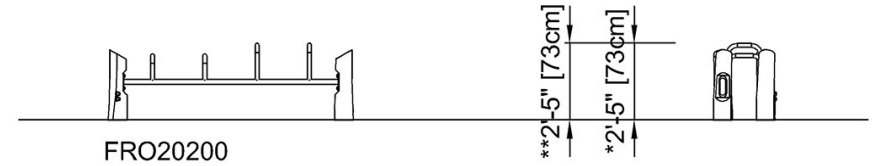
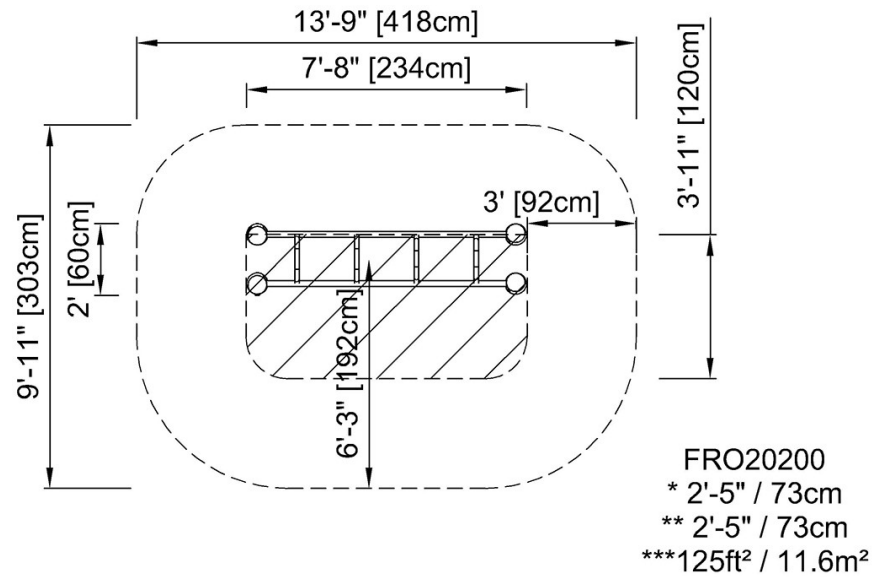

[Click to see TOP VIEW](#)

[Click to see SIDE VIEW](#)