

Four Tower with Bridges

PCM410421

Item no. PCM410421-0951

General Product Information

Dimensions LxWxH	428x669x380 cm
Age group	4+
Play capacity (users)	26
Color options	

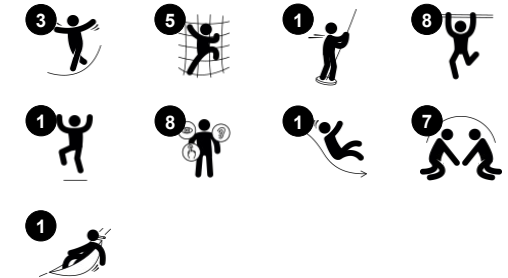

The four tower play universe is a magnet for climbing, balancing and rough-and-tumble play, its transparency and play variation is a haven for older children. The transparency makes it possible to see all the other children playing, stimulating social interaction and positive competition making play last for longer. The longer children are playing new games are

created such as, do-not-touch-the-ground meaning children test out a wide scope of physical competences and social skills. The variety of nets and balance links challenge children's agility, balance and cross-coordination whilst allowing for more children to play together in groups. There are varied entry points to the tower, from the fast access stairs

and climbing wall to the inclined crawling access, ensures the tower is suitable for a variety of ages and user abilities.

Four Tower with Bridges

PCM410421



Panels of 19mm EcoCore™. EcoCore™ is a highly durable, eco friendly material, which is not only recyclable after use, but also consists of material produced from +95% recycled post consumer material from food packing waste.



All decks are supported by unique designed low-carbon aluminum profiles with multiple attachment options. The grey colored molded decks are made of 75% post-consumer waste PP material with a non-skid pattern and texture surface.



Main posts with hot dip galvanized steel footing are available in different materials: Pressure impregnated pine wood posts. Pre-galvanized inside and outside with powder coated top finish steel posts. Lead free aluminum with color anodized top finish. Greenline TexMade posts of 95% post-consumer recycled PE and textile waste.

Item no. PCM410421-0951	
Installation Information	
Max. fall height	224 cm
Safety surfacing area	55.2 m ²
Total installation time	27.1
Excavation volume	0.79 m ³
Concrete volume	0.06 m ³
Footing depth (standard)	90 cm
Shipment weight	1,118 kg
Anchoring options	In-ground ✓ Surface ✓

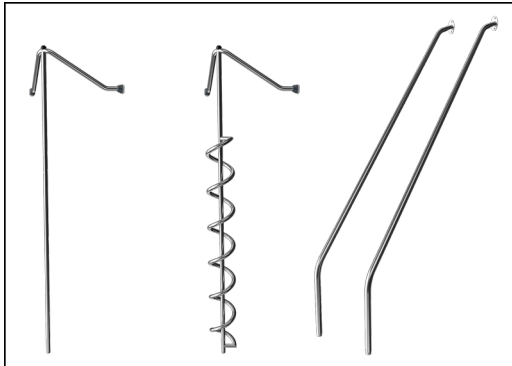

The stainless-steel activities are made of high-quality stainless steel. The steel is cleaned by a total pickling process after manufacturing to ensure a smooth and clean gliding surfaces.



The slides can be chosen in six different colors and three materials: Straight or curved one-piece molded PE slides, made from 33% recycled post-consumer materials in different colours. Combined EcoCore™ sides and stainless-steel. Full stainless steel in one piece design for more vandalism proof solutions.



KOMPAN GreenLine versions are designed with ultimate environmentally friendly materials with lowest possible CO2e emission factor. TexMade post, EcoCore™ panels of 95% post-consumer recycled waste and molded PP decks.



Sustainability Data

PCM410421



Cradle to Gate A1-A3	Total CO ₂ emission	CO ₂ e/kg	Recycled materials
	kg CO ₂ e	kg CO ₂ e/kg	%
PCM410421-0951	1,518.40	1.99	68.40
PCM410421-0905	1,890.50	3.12	48.70

The overall framework applied for these factors is the Environmental Product Declaration (EPD), which quantifies "environmental information on the life cycle of a product and enable comparisons between products fulfilling the same function" (ISO, 2006). This follows the structure and applies a Life-Cycle Assessment approach to the entire Product stage from raw material through manufacturing (A1-A3))

Kompan A/S
 C.F. Tietgens Boulevard 32C
 DK-5220 Odense SØ
 Denmark



Verification of CO₂ calculation of: Play systems



Data version no. 2023-10-05

The CO₂ calculation and data are in compliance with the principles of a carbon footprint impact according to the GHG protocol (Greenhouse Gas Protocol), Scope 3, cradle to gate related to all individual components in the product category: "Play systems" represented by item no.: PCM200321-0950.

(Scope 3 emissions include emission sources in the upstream and downstream value chain).

Date: 30. October 2023 | Valid until: 30. October 2025

Verified by:

Julie Marie Vejsgaard Larsen, LCA & EPD Consultant

Verification based on report: Validation of CO₂ calculation of 9 categories of Kompan product line, version 1.0, prepared by: Bureau Veritas HSE, Denmark: Julie M. V. Larsen.

Publication date: 30. October 2023

By Bureau Veritas HSE
 www.bureauveritas.dk
 +45 7731 1000



Four Tower with Bridges

PCM410421

* Max fall height | ** Total height | *** Safety surfacing area

* Max fall height | ** Total height

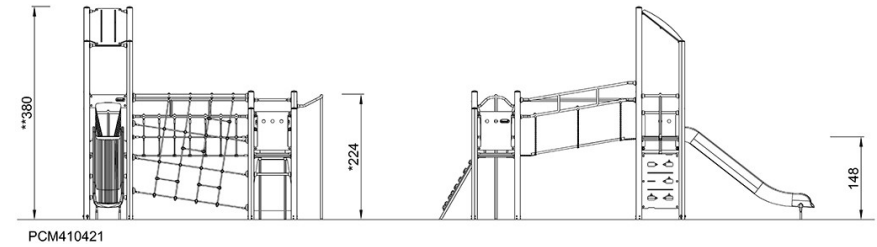
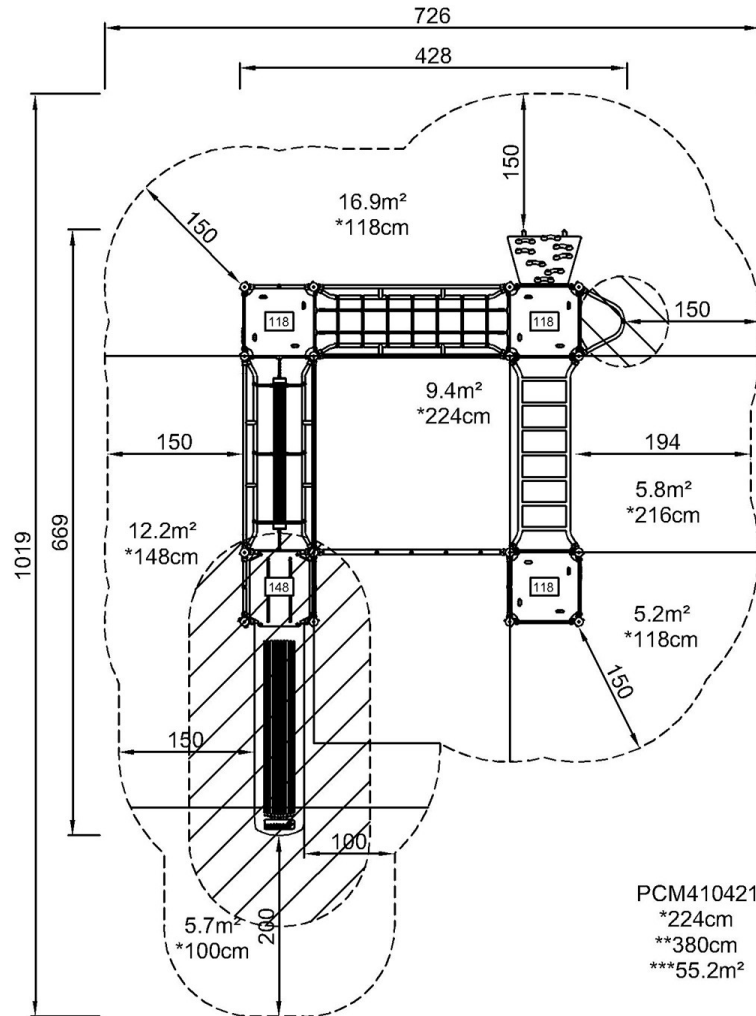

[Click to see TOP VIEW](#)

[Click to see SIDE VIEW](#)