

# Balance Beam, Round

PCM80621



Item no. PCM80621-0901	
<b>General Product Information</b>	
Dimensions LxWxH	7'5"x0'5"x1'6"
Age group	5 - 12
Play capacity (users)	2
Color options	●



The Balance Beam is a great playground classic, that attracts children again and again. It can function as playground glue, connecting activities and friends. It can also function as a point for a break, providing seating for children sharing, or parents or carers in need of a point from which to observe the children play. When children balance across the Balance Beam,

they train their equilibrium immensely. The sense of balance is a fundamental motor skill, that is basic for the development of all other skills. The sense of balance for instance makes it possible for children to sit still and concentrate. So the fun of physical play supports child development. The spaciousness allows for ample social interaction and

cooperative play.



# Balance Beam, Round

PCM80621



## Balance beam

**Physical:** trains the sense of balance, fundamental for all other motor skills that make it possible to navigate the world confidently and securely. **Social-Emotional:** turn-taking skills and negotiation when crossing each other on the beam. Room for a seated rest and exchange.

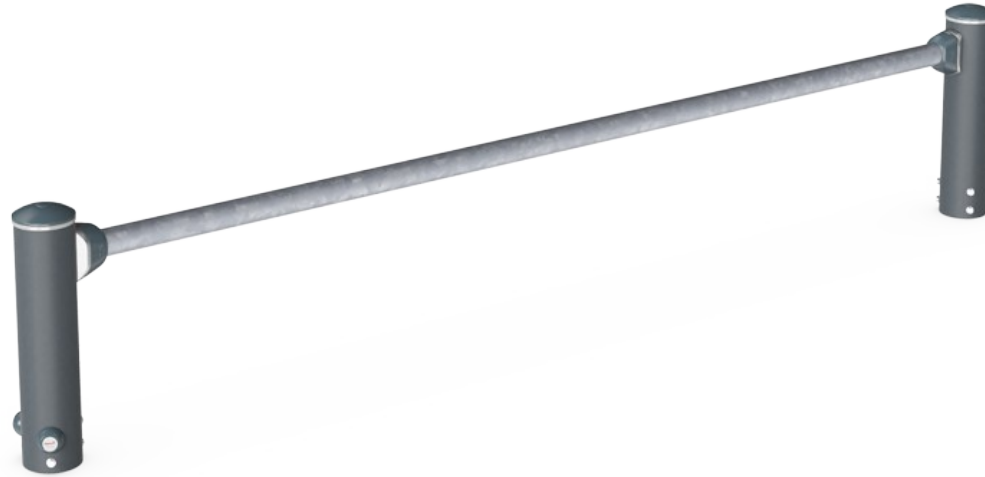

# Balance Beam, Round

PCM80621

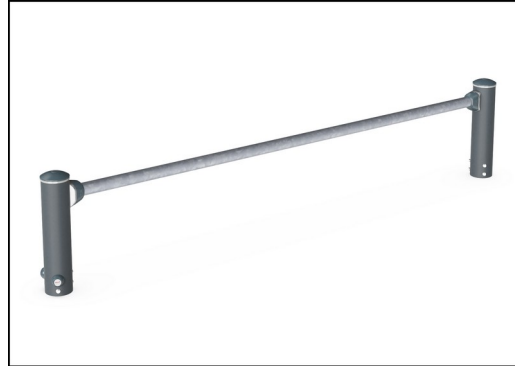

Main posts with hot-dip galvanized steel footing are available in different materials: Pressure impregnated pinewood posts. Pre-galvanized inside and outside with powder-coated top finish steel posts. Lead-free aluminum with color anodized top finish. Greenline TexMade posts of 100% post-consumer recycled PE and textile waste.

The steel surfaces are hot-dip galvanized inside and outside with lead-free zinc. The galvanization has excellent corrosion resistance in outside environments and requires minimal maintenance.

Item no. PCM80621-0901	
Installation Information	
Max. fall height	1'4"
Safety surfacing area	208ft <sup>2</sup>
Total installation time	2.5
Excavation volume	0.08yd <sup>3</sup>
Concrete volume	0.04yd <sup>3</sup>
Footing depth (standard)	2'11"
Shipment weight	71lbs
Anchoring options	Surface ✓ In-ground ✓
Warranty Information	
HDG post	Lifetime
Post	10 Years
Spare Parts Availability	10 Years

Elevated activities 0	Accessible elevated activities	Accessible ground level activities	Accessible ground level play types
Present	0	1	1
Required	0	0	0

**ASTM  
F1487**  
compliant

# Sustainability Data

PCM80621

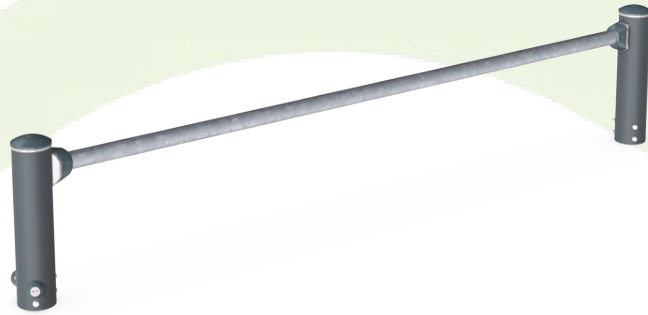

Cradle to Gate A1-A3	Total CO <sub>2</sub> emission	CO <sub>2</sub> e/kg	Recycled materials
	kg CO <sub>2</sub> e	kg CO <sub>2</sub> e/kg	%
<b>PCM80621-0901</b>	77.66	3.14	45.85

The overall framework applied for these factors is the Environmental Product Declaration (EPD), which quantifies "environmental information on the life cycle of a product and enable comparisons between products fulfilling the same function" (ISO, 2006). This follows the structure and applies a Life-Cycle Assessment approach to the entire Product stage from raw material through manufacturing (A1-A3))

**Kompan A/S**  
 C.F. Tietgens Boulevard 32C  
 DK-5220 Odense SØ  
 Denmark



## Verification of CO<sub>2</sub> calculation of: Freestanding play equipment



Data version no. 2023-10-05

The CO<sub>2</sub> calculation and data are in compliance with the principles of a carbon footprint impact according to the GHG protocol (Greenhouse Gas Protocol), Scope 3, cradle to gate related to all individual components in the product category: "Freestanding play equipment" represented by item no.: GXY916012-3417.

(Scope 3 emissions include emission sources in the upstream and downstream value chain).

**Date: 30. October 2023 | Valid until: 30. October 2025**

**Verified by:**

Julie Marie Vejsgaard Larsen, LCA & EPD Consultant

Verification based on report: Validation of CO<sub>2</sub> calculation of 9 categories of Kompan product line, version 1.0, prepared by: Bureau Veritas HSE, Denmark: Julie M. V. Larsen.

**Publication date: 30. October 2023**

**By Bureau Veritas HSE**  
 www.bureauveritas.dk  
 +45 7731 1000



# Balance Beam, Round

PCM80621

\* Max fall height | \*\* Total height | \*\*\* Safety surfacing area

\* Max fall height | \*\* Total height

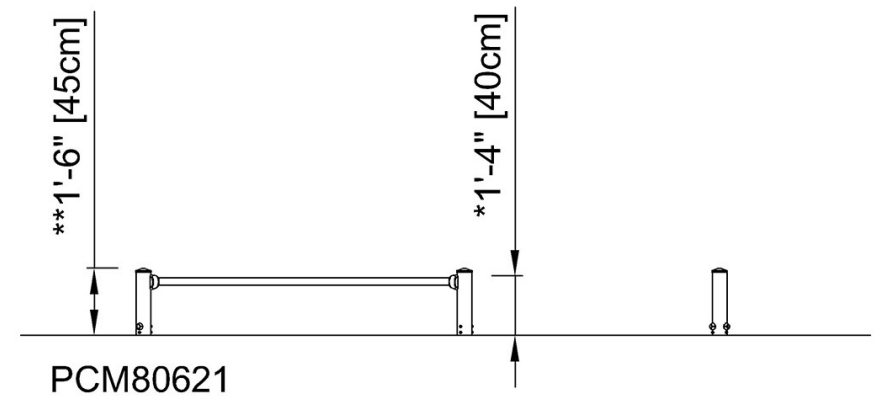
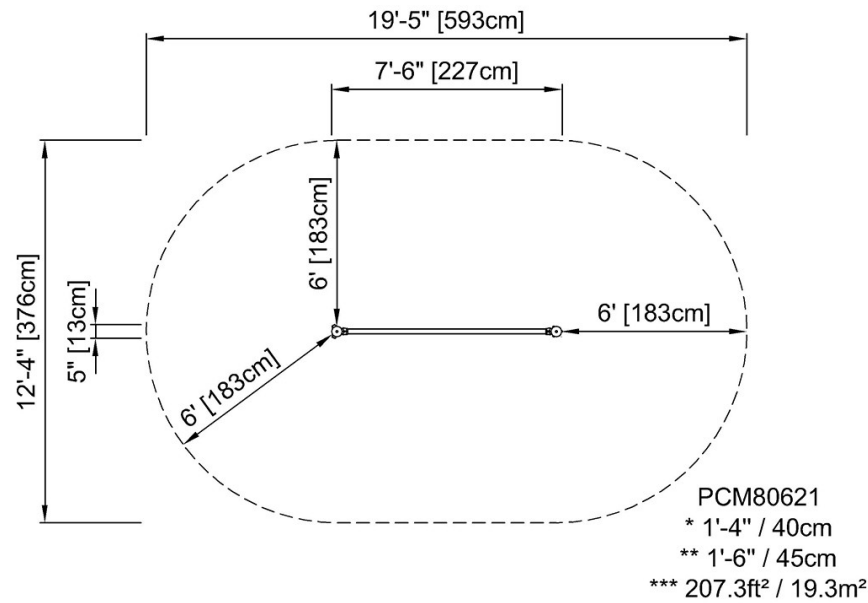

[Click to see TOP VIEW](#)

[Click to see SIDE VIEW](#)