

# Play Tower with Climbing Net

PCM101531



| Item no. PCM101531-0651     |                |
|-----------------------------|----------------|
| General Product Information |                |
| Dimensions LxWxH            | 425x302x306 cm |
| Age group                   | 2 - 5          |
| Play capacity (users)       | 13             |
| Colour options              |                |



The Play Tower with Climbing Net attracts and excites growing toddlers to physical play again and again. The accessible stairway apart makes children run up the stairs and slide down the slide tirelessly. Apart from being fun, children also train their muscles and foundational motor skills this way. When sliding, children train their sense of balance,

which is foundational for all other motor skills and physical actions. The big net is wonderful to climb, and the big, slightly swaying meshes are fine destinations for a break. When they climb the big net, children stimulate their cross-coordination, which is a skill that lays the fundament for later reading skills. The somersault bar children will master as their

physical confidence grows. It trains the spatial awareness as well as proprioception. The tactile abacus is a lovely tactile feature that trains the understanding of space, shapes and measures. Loads of play in little space.

# Play Tower with Climbing Net

PCM101531

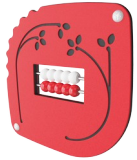

## Abacus

**Cognitive:** supports understanding of measures.



## Slide

**Physical:** sliding develops spatial awareness and a sense of balance. Furthermore, the core muscles are trained when sitting upright going down. **Social-Emotional:** empathy stimulated by turn-taking. **Cognitive:** young children develop their understanding of space, speed and distances when sliding down quickly.



## Somersault bar

**Physical:** develop balance and core when hanging from knees. Arm, leg and core muscles are developed when climbing up, somersaulting around. Balance and spatial awareness are strengthened. **Social-Emotional:** meeting, socializing and turn-taking when climbing up and down via bar.



## Climbing net

**Physical:** children develop cross-body coordination and muscle strength when climbing. The big meshes allow for climbing and crawling through, supporting proprioception and spatial awareness. **Social-Emotional:** the big meshes allow for more children to sit together and talk.



## Pipe ladder

**Physical:** cross coordination and eye-hand coordination are supported when children climb the ladder. The climbing also supports leg and arm muscles. **Social-Emotional:** learning about turn taking and cooperation.

# Play Tower with Climbing Net

PCM101531



Panels of 19mm EcoCore™. EcoCore™ is a highly durable, eco friendly material, which is not only recyclable after use, but is also produced from +95% recycled post consumer material from food packing waste. Wooden panels of impregnated and brown painted pine wood with vertical steel profiles.



Main posts with hot dip galvanized steel footing are available in different materials: Pressure impregnated pine wood posts. Pre-galvanized inside and outside with powder coated top finish steel posts. Lead free aluminum with color anodized top finish. Greenline TexMade posts of 95% post-consumer recycled PE and textile waste.

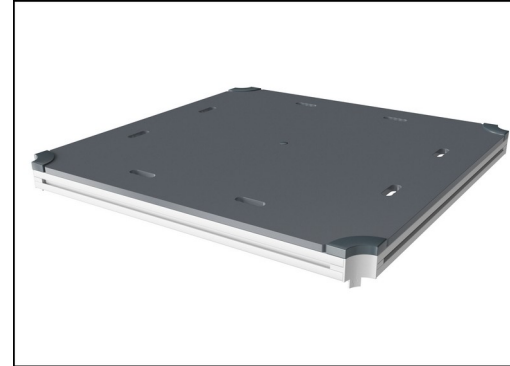

All decks are supported by unique designed low-carbon aluminum profiles with multiple attachment options. The grey colored molded decks are made of 75% post-consumer waste PP material with a non-skid pattern and texture surface.

| Item no. PCM101531-0651  |  |
|--------------------------|--|
| Installation Information |  |
| Max. fall height         | 193 cm   |
| Safety surfacing area    | 40.3 m <sup>2</sup>  |
| Total installation time  | 15.0   |
| Excavation volume        | 0.33 m <sup>3</sup>  |
| Concrete volume          | 0.00 m <sup>3</sup>  |
| Footing depth (standard) | 60 cm  |
| Shipment weight          | 509 kg   |
| Anchoring options        | In-ground <input checked="" type="checkbox"/><br>Surface <input checked="" type="checkbox"/> |
| Warranty Information     |  |
| EcoCore HDPE             | Lifetime   |
| Post                     | 10 years   |
| PP Decks                 | 10 years   |
| Ropes & nets             | 10 years   |
| Spare parts guaranteed   | 10 years   |



Ropes of UV-stabilized PES rope strands with inner steel cable reinforcement. The polyester yarn is made from +95% post-consumer materials and is inductively melted onto each strand.

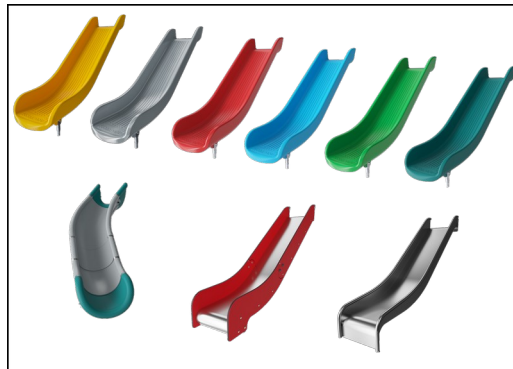

The slides can be chosen in six different colors and three materials: Straight or curved one-piece molded PE slides, made from 33% recycled post-consumer materials in different colours. Combined EcoCore™ sides and stainless-steel. Full stainless steel in one piece design for more vandalism proof solutions.



KOMPAN GreenLine versions are designed with ultimate environmentally friendly materials with lowest possible CO2e emission factor. TexMade post, EcoCore™ panels of 95% post-consumer recycled waste and molded PP decks.

| Elevated activities 3 | Accessible elevated activities | Accessible ground level activities | Accessible ground level play types |
|-----------------------|--------------------------------|------------------------------------|------------------------------------|
| Present               | 3                              | 1                                  | 1                                  |
| Required              | 2                              | 1                                  | 1                                  |

**CSA  
Z614**  
compliant

# Sustainability Data

PCM101531



| Cradle to Gate A1-A3  | Total CO <sub>2</sub> emission | CO <sub>2</sub> e/kg    | Recycled materials |
|-----------------------|--------------------------------|-------------------------|--------------------|
|                       | kg CO <sub>2</sub> e           | kg CO <sub>2</sub> e/kg | %                  |
| <b>PCM101531-0651</b> | 615.41                         | 1.72                    | 67.15              |
| <b>PCM101531-0605</b> | 802.00                         | 2.54                    | 52.83              |

The overall framework applied for these factors is the Environmental Product Declaration (EPD), which quantifies "environmental information on the life cycle of a product and enable comparisons between products fulfilling the same function" (ISO, 2006). This follows the structure and applies a Life-Cycle Assessment approach to the entire Product stage from raw material through manufacturing (A1-A3))

**Kompan A/S**  
 C.F. Tietgens Boulevard 32C  
 DK-5220 Odense SØ  
 Denmark



## Verification of CO<sub>2</sub> calculation of: Play systems



Data version no. 2023-10-05

The CO<sub>2</sub> calculation and data are in compliance with the principles of a carbon footprint impact according to the GHG protocol (Greenhouse Gas Protocol), Scope 3, cradle to gate related to all individual components in the product category: "Play systems" represented by item no.: PCM200321-0950.

(Scope 3 emissions include emission sources in the upstream and downstream value chain).

**Date: 30. October 2023 | Valid until: 30. October 2025**

Verified by:

Julie Marie Vejsgaard Larsen, LCA & EPD Consultant

Verification based on report: Validation of CO<sub>2</sub> calculation of 9 categories of Kompan product line, version 1.0, prepared by: Bureau Veritas HSE, Denmark: Julie M. V. Larsen.

**Publication date: 30. October 2023**

By Bureau Veritas HSE  
 www.bureauveritas.dk  
 +45 7731 1000



# Play Tower with Climbing Net

PCM101531

\* Max fall height | \*\* Total height | \*\*\* Safety surfacing area

\* Max fall height | \*\* Total height

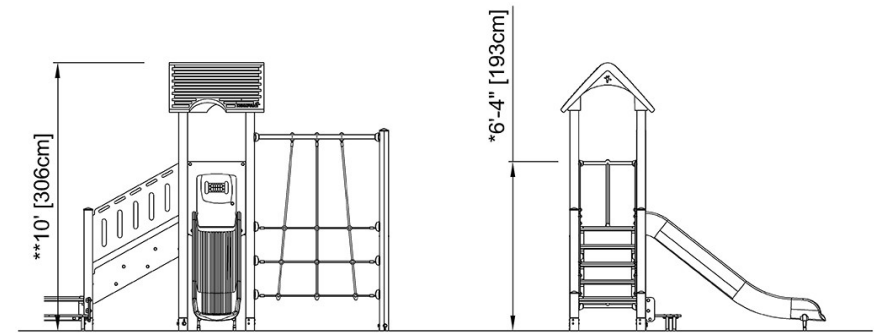
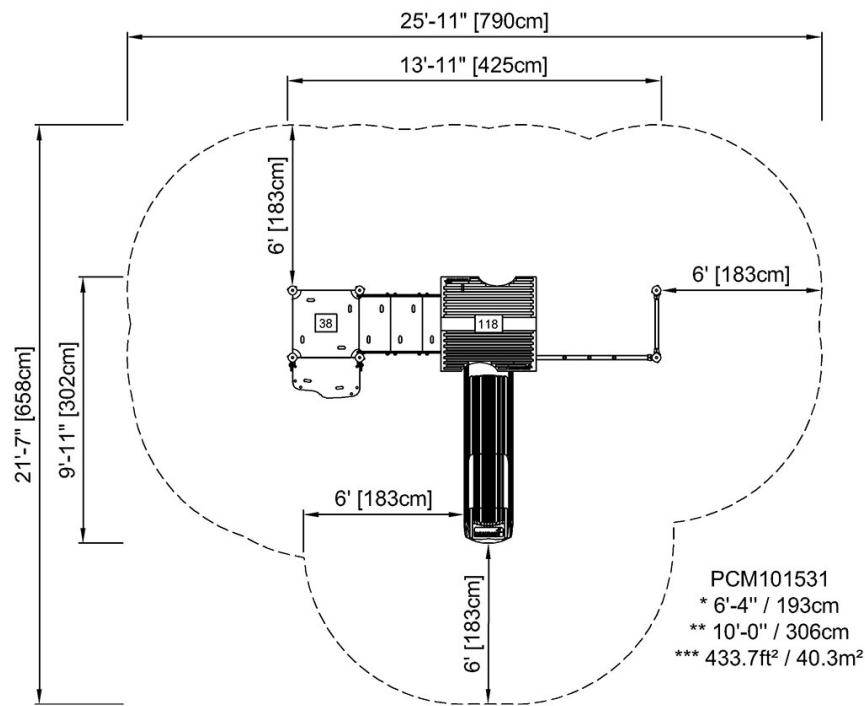

PCM101531

[Click to see TOP VIEW](#)

[Click to see SIDE VIEW](#)