

Wooden Rope Climber L

KPW250501

KOMPANI®



产品编号 KPW250501-0901

产品信息概览

长宽高尺寸	491x272x282 cm
适用年龄段	4+
容纳人数	16
颜色选择	●

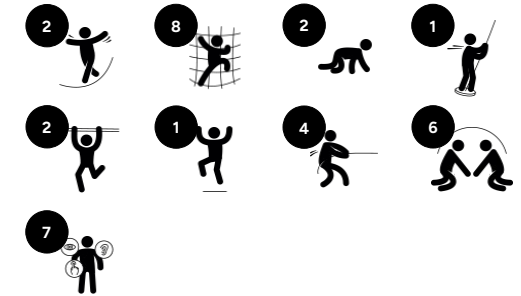

The Wooden Rope Climber immediately attracts children to the dense activity hub. Thanks to the varied climbing activities and route opportunity, all children have a chance of doing something. The fireman's pole provides a thrilling destination. The openness in design also invites conversation and social interaction across the Climber. This supports children's

socio-emotional development. With its combination of activities, the Climbing Structure stimulates children's cross-coordination, strength and bone density. All of these abilities are built for life in childhood.

Wooden Rope Climber L

KPW250501

KOMPANI®



攀爬网

身体素质：儿童在攀爬时可训练跨体协调能力
和肌肉力量。大网眼设计便于攀爬和爬行，有
助于训练本体感觉和空间意识。 **社交情感：**绳
网中的大网格可以让更多的孩子坐在一起分享
交流。

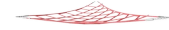

横向网

身体素质：在翻越时培养交叉协调能力，在上
方向下俯视时培养空间感。 **社交情感：**为社交
和弹跳间的休息提供空间。



管道梯

身体素质：孩子们在爬梯的过程中，交叉协调
能力和眼手协调能力都得到了锻炼。攀爬还能
锻炼腿部和手臂肌肉。 **社交情感：**培养轮流意
识和合作意识。



支撑手持装置

身体素质：手柄可为不太自信的攀爬儿童提供
良好的抓力。将自己拉起并拉入绳网，可锻炼
上身肌肉。



平衡木

身体素质：训练其他运动技能所需的基础能力
——平衡感，让儿童在周围世界中安全自信地
行走。 **社交情感：**当在平衡木上错身经过时可
以训练轮流技能和协商能力。适合坐下休息和
相互交流的空间。



消防员爬杆

身体素质：当下降时，协调得到支持，同时也
锻炼了手臂和核心肌肉。着地时会增强骨密度，
这对于儿童早期生活中的骨骼建设至关重要。
社交情感：训练轮流意识和风险意识。 **认知能
力：**幼儿在快速滑下时可训练对空间、速度和
距离的理解。

Wooden Rope Climber L

KPW250501

KOMPAN[®]

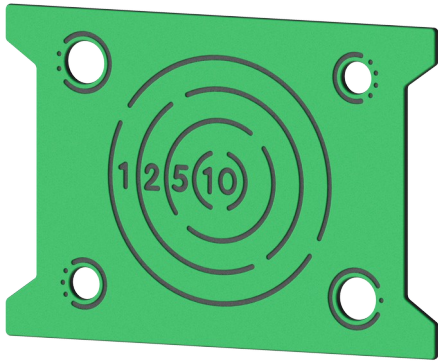

19 毫米 EcoCore™ 面板。EcoCore™ 是一种高度耐用、环保的材料，不仅在使用后可回收利用，而且还包含由 100 % 食品包装可循环材料制成的芯。



主塔柱有两种类型的材料：欧洲松木柱，根据 EN335 标准，木材进行 3 级压力浸渍（相当于 NTR AB 级）。铝柱 t = 2mm，经阳极氧化表面处理。基础材料 EN AW-6060 T66。

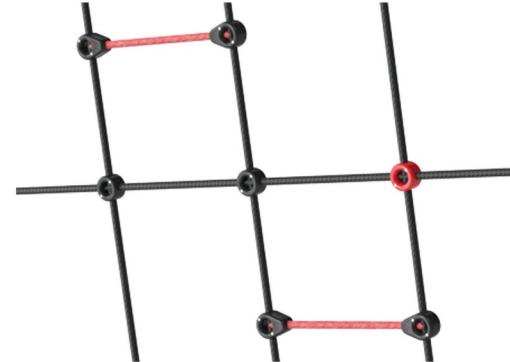

绳索由防紫外线的 PES 绳股制成，并带有内部钢缆增强件。聚酯包裹的绳股经过感应处理，融化到每根单独的丝束上，以获得优异的耐磨性和抗撕裂性。

产品编号 KPW250501-0901

安装信息

最大跌落高度	148 cm
安全面积	31.8 m ²
安装总时长	10.8 小时
开挖量	1.33 m ³
混凝土使用量	0.68 m ³
标准入地深度	90 cm
运输重量	355 kg
固定选项	入地 ✓ 地表 ✓

质保信息

松木	10 年
铝	15 年
EcoCore HDPE	终身质保
绳网	10 年
承保零部件	10 年

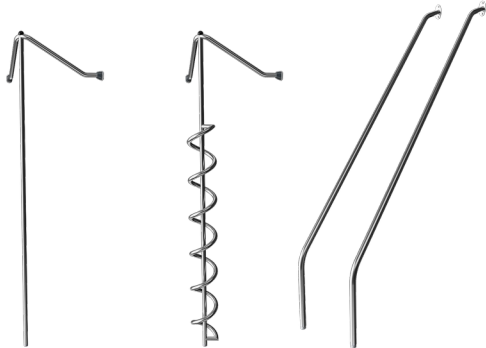

不锈钢游戏活动部件由优质不锈钢制成。在制造后使用酸洗工艺对钢进行清洁，以确保光滑和清洁的顺滑表面。

EN
1176
compliant



Independent review certificate

Kompan A/S
C. F. Tietgens Blvd. 32C, 5220 Odense SØ

Bureau Veritas hereby attests that the CO₂e-calculations (covering materials, processing, waste and transport) done by Kompan for "Nature Play", meet the requirements set by the listed standard.

Kompan A/S uses a selection of EPDs and emission factors from the Life Cycle Assessment database Ecoinvent 3.11. These values are reported as kg CO₂e, with all other impact categories excluded in line with the scope of ISO 14067:2018. The emission factors cover, material use, manufacturing processes, transport to Kompan, and electricity used during manufacturing. The presented emissions fall under GHG Protocol scope 3 emissions. Scope 1 and 2 are not presented. Scope 3 emissions include emission sources in the upstream value chain of a company, downstream emissions are excluded in this analysis.

Method: ISO 14067:2018 using GHG protocol guidance documents, reported as kg CO₂e.

Object

The verification has been done on the one pager "NRO40901-0601" version: 27-10-2025. The supporting documentation "KOMPAN data_updated emissions factors_2025_V2" and "Emissions factors, EPD's and ecoinvent 3.11_2025" was also reviewed and approved.

Declaration

The verification has been completed as a critical review with a limited assurance. I hereby confirm that nothing has come to the reviewer's attention which would lead to conclude that the study does not give an accurate depiction or isn't completed following method of the CO₂e calculation, the requirements of ISO 14067:2018, and 14071:2024, in the above referenced documentation.

Note: This verification only covers calculation elements according to method described in ISO 14067:2018 and may not be seen as a Life Cycle Assessment according to ISO 14067:2018.

Ref.: Kompan_Verification report 2025, 28-10-2025

Date of certificate: 29-10-2025

Expire date: 29-10-2027

Verified by: Julie Marie Vejsgaard Larsen, Environmental Auditor

Signature:

从原材料到成品

CO₂ 排放总量

kg CO₂e

CO₂ 排放量 / 千克

kg CO₂e/kg

回收的原料

%

KPW250501-0901

674.96

2.61

26.84

这些因素采用的总体框架为环保产品声明 (EPD), 该声明可量化“产品生命周期的环保信息, 并对相同功能的产品进行对比” (ISO, 2006)。在遵循该框架的同时, 对从原材料到制造的整个产品阶段 (A1-A3) 应用生命周期评估法。

Wooden Rope Climber L

KPW250501

最大跌落高度 | 总高度 | 安全区域

最大跌落高度 | 总高度

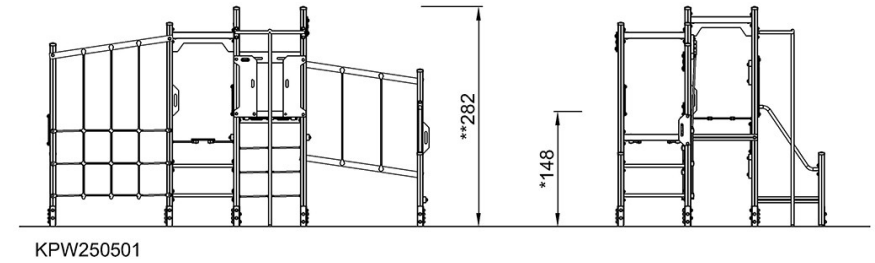
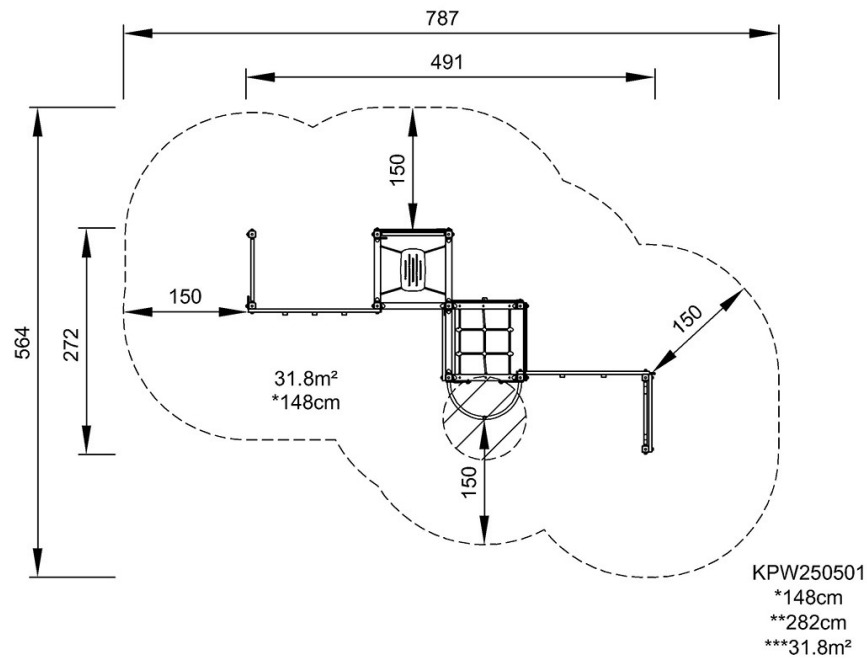

[点击查看俯视图](#)

[点击查看侧面图](#)