

Ocean & Jungle

MSC6402

KOMPAN
Let's play



Item no. MSC640200-3717P

General Product Information

Dimensions LxWxH	346x375x286 cm
Age group	2+
Play capacity (users)	20
Color options	

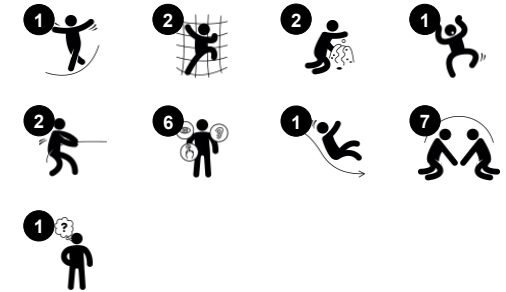

WOW! The Ocean & Jungle themes hugely appeal to children's urge for dramatic play stories. The under-deck den invites a break with friends. There is an Ocean side and a Jungle side, inspiring wild explorer play stories. Thanks to the two-sided themed panels and the curved and inclined choice of access points, the Ocean & Jungle challenges a wide

user group. The curved climbing wall and the inclined climbing net train motor skills in their own ways, such as through cross-coordination. This influences the brain's ability to read and write. It builds up body confidence, too, making children more secure in moving through the world. The Ocean & Jungle can be played on all sides. From the upper level, a megaphone

encourages communication with the outside. Here children meet, greet and play, making friends for life.

Ocean & Jungle

MSC6402

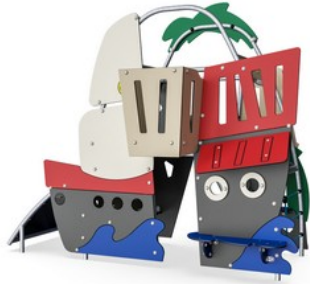

Panels of 19mm EcoCore™. EcoCore™ is a highly durable, eco friendly material, which is not only recyclable after use, but also consists of material produced from +95% recycled post consumer material from food packing waste.

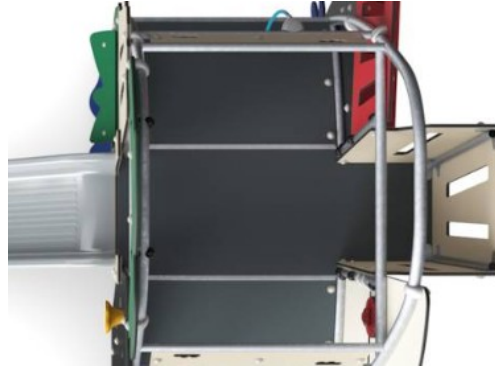

All floors are made of High-Pressure Laminate HPL with a thickness 17.8mm and non skid surface texture according to EN 438-6. KOMPAN HPL has high wearing strength to ensure long lifetime in all climates.

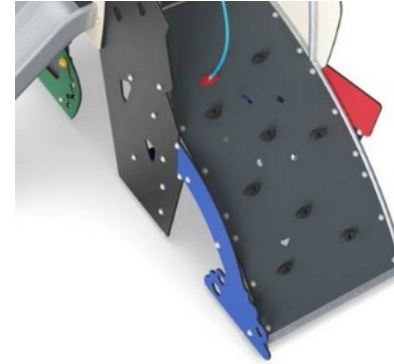

Curved climbing wall is made of Ekogrip® panel that consist of a 15mm thick PE base with 3 mm top-layer of soft rubber with a non-skid effect.

Item no. MSC640200-3717P

Installation Information

Max. fall height	120 cm
Safety surfacing area	31.3 m ²
Total installation time	21.0
Excavation volume	0.80 m ³
Concrete volume	0.00 m ³
Footing depth (standard)	90 cm
Shipment weight	691 kg
Anchoring options	In-ground ✓ Surface ✓



The slide is made of moulded PE. PE has high impact resistance across a wide temperature span which ensures vandal resistance in all locations.

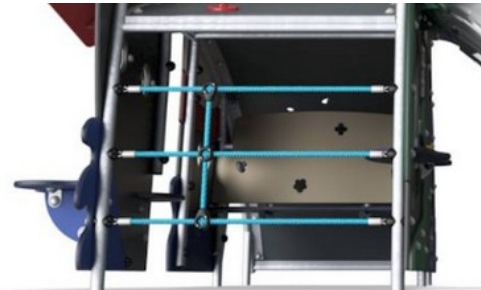

Ropes are made of UV-stabilised PA with inner steel cable reinforcement. The rope is induction treated in order to create a strong connection between steel and rope which leads to good wear resistance.



The steel surfaces are hot dip galvanised inside and outside with lead free zinc. The galvanisation has excellent corrosion resistance in outside environments and requires low maintenance.



Sustainability Data

MSC6402



Cradle to Gate A1-A3	Total CO ₂ emission	CO ₂ e/kg	Recycled materials
	kg CO ₂ e	kg CO ₂ e/kg	%
MSC640200-3717P	1,132.50	2.18	57.10

The overall framework applied for these factors is the Environmental Product Declaration (EPD), which quantifies "environmental information on the life cycle of a product and enable comparisons between products fulfilling the same function" (ISO, 2006). This follows the structure and applies a Life-Cycle Assessment approach to the entire Product stage from raw material through manufacturing (A1-A3))

Kompan A/S
 C.F. Tietgens Boulevard 32C
 DK-5220 Odense SØ
 Denmark



Verification of CO₂ calculation of: Themed play systems



Data version no. 2023-10-05

The CO₂ calculation and data are in compliance with the principles of a carbon footprint impact according to the GHG protocol (Greenhouse Gas Protocol), Scope 3, cradle to gate related to all individual components in the product category: "Themed play systems" represented by item no.: MSC641100-3717P.

(Scope 3 emissions include emission sources in the upstream and downstream value chain).

Date: 30. October 2023 | Valid until: 30. October 2025

Verified by:

Julie Marie Vejsgaard Larsen, LCA & EPD Consultant

Verification based on report: Validation of CO₂ calculation of 9 categories of Kompan product line, version 1.0, prepared by: Bureau Veritas HSE, Denmark: Julie M. V. Larsen.

Publication date: 30. October 2023

By Bureau Veritas HSE
 www.bureauveritas.dk
 +45 7731 1000



Ocean & Jungle

MSC6402

* Max fall height | ** Total height | *** Safety surfacing area

* Max fall height | ** Total height

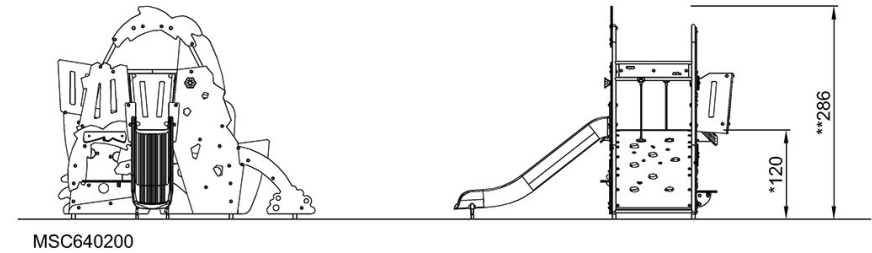
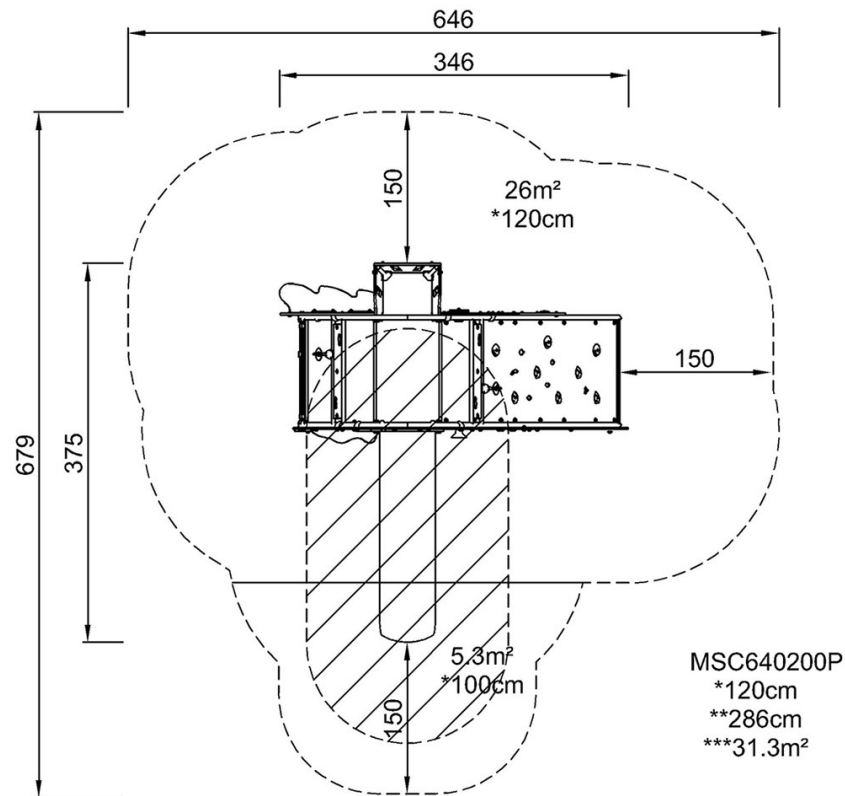

[Click to see TOP VIEW](#)

[Click to see SIDE VIEW](#)