

Creator

PCE305021

Item no. PCE305021-0603

General Product Information

Dimensions LxWxH	829x632x173 cm
Age group	2+
Play capacity (users)	32
Colour options	  

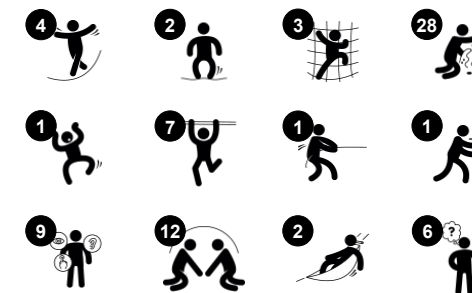

The Creator is the ultimately versatile unit for the youngest players. The varied activities make them return again and again. All activities support the fundamental development of physical, social-emotional, cognitive and creative skills. The bouncy and swaying rubber features are responsive, which toddlers love. In addition, it trains the understanding of cause-

and-effect and the turn-taking skills. The membrane bridge builds coordination and bone density when children jump. The net and monkey bars develop cross-coordination and upper body strength. The enticing play corner and panels at ground level add sensory play events, such as music and sound, and promotes agility as well as logical thinking

skills. Ground level transparent play events mean communication throughout and play for all abilities.



Data is subject to change without prior notice.

Creator

PCE305021



Xylophone music panel

Social-Emotional: invites social interaction and co-creation for more children, on both sides. **Cognitive:** understanding of cause and effect when striking tubes and creating sound. **Creative:** the creation of different intensity and tonality stimulates creative skills.

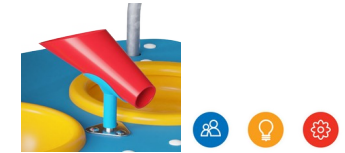

Changeable sand funnel

Social-Emotional: supports cooperation and turn-taking as children pour water or materials into the funnel. **Cognitive:** the passing of materials through funnels develops children's logical thinking, for younger children the understanding of object permanence: that materials do not vanish, but run through. **Creative:** the sand funnel can be turned, creating new directions of dispensing materials.



Overhead ladder

Physical: develops children's upper body muscles and arm strength, cross coordination and spatial awareness. This is especially important due to sedentary lifestyles and back-pain in children. **Social-Emotional:** chill and socialize on top of the overhead ladder, training cooperation.



Flower panel

Social-Emotional: invites cooperation due to the two-sides and provides for parallel play. **Cognitive:** stimulates cause and effect and logical thinking: sounds are made when the flower moves through the grooves. **Creative:** children can leave their mark, placing the flowers in different positions.



Climbing net twist

Physical: cross coordination and muscle strength when on net. Sense of balance when swaying on red plate. **Social-Emotional:** breaks are invited on the horizontal parts of the twisted net, allowing for socialising. **Cognitive:** figuring out how to position body to climb the twisted net.



Membrane bridge

Physical: agility, balance and coordination, force of movement and sense of effort. Development of bone density when jumping. **Social-Emotional:** turn-taking, problem solving and cooperation when bouncing others. Relaxation when lying or sitting, being bounced by others. **Cognitive:** understanding of 'cause and effect' as well as logical thinking.



Flap door

Physical: tactile stimulation from leaning the body through rubber doors. **Cognitive:** suggests a theme and supports dramatic play, which stimulates language and communication skills.

Creator

PCE305021



The Curved ELEMENTS panels are moulded of UV stabilised recyclable PE with multiple options for in-built play features that also ensures a strong panel solution. Straight panels are made of KOMPAN 19mm PE EcoCore™ which is a highly durable, eco-friendly and recyclable material.

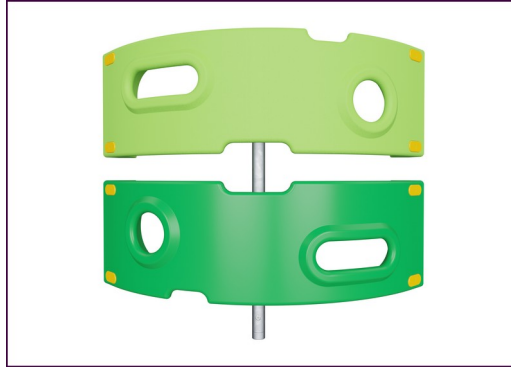

The climbing elements displayed are moulded in one piece with a minimum 5mm wall thickness. The climbing elements are made of recyclable PE, which has a high impact resistance across a wide temperature span and is also vandal resistance.

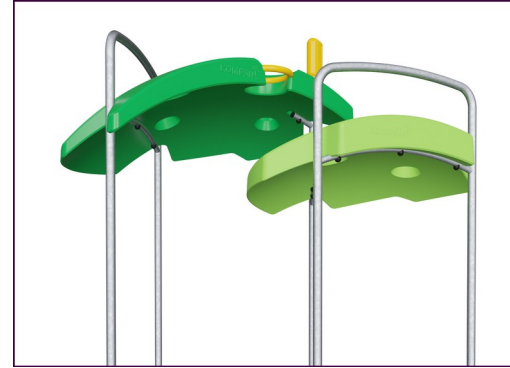

The ELEMENTS roofs are made of recyclable PE with a minimum wall thickness of 5 mm to ensure high durability in all climates around the world. The steel pipes are hot-dip galvanised inside and outside for maximum durability.



The main posts are made of high quality pre-galvanized steel with powder coated top finish. Post tops are closed with caps of UV stabilized nylon (PA6). The grey colored molded decks are made of 75% post-consumer ocean waste PP material with a non-skid pattern and textured surface. All decks are supported by uniquely designed, low-carbon aluminum profiles with multiple attachment options.

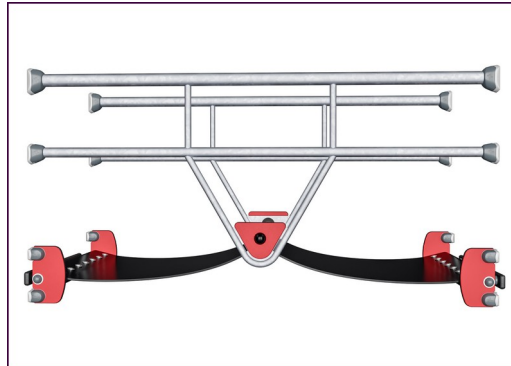

ELEMENTS rubber membranes are conveyor belt made of layers of rubber mixed of natural rubber and SBR rubber and embedded with layers of armouring made of woven PE and PA. The thickness 8mm ensures high durability in any environment.

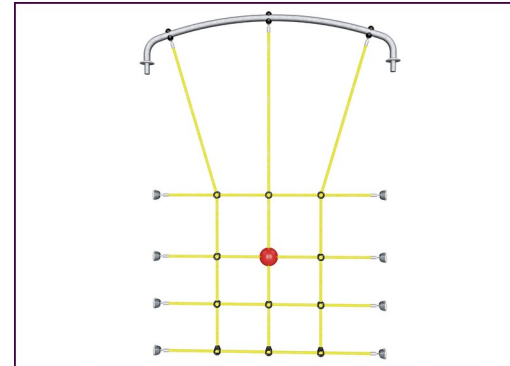

ELEMENTS ropes have six-stranded steel wires and a steel wire core. Each strand is tightly wrapped with PES yarn, which is melted onto each individual strand. After initial friction has removed the surface fibres, a harder PES coating remains to protect each strand, making the ropes highly wear and vandalism resistant.

Item no. PCE305021-0603

Installation Information

Max. fall height	166 cm
Safety surfacing area	69.7 m ²
Total installation time	27.9
Excavation volume	0.60 m ³
Concrete volume	0.13 m ³
Footing depth (standard)	60 cm
Shipment weight	842 kg
Anchoring options	Surface ✓ In-ground ✓

Warranty Information

Curved Panels	10 years
EcoCore HDPE	Lifetime
Membrane	2 years
Post	10 years
Spare Parts Guarantee	10 years



Sustainability Data

PCE305021



Cradle to Gate A1-A3	Total CO ₂ emission	CO ₂ e/kg	Recycled materials
	kg CO ₂ e	kg CO ₂ e/kg	%
PCE305021-0603	1,942.99	3.04	43.84

The overall framework applied for these factors is the Environmental Product Declaration (EPD), which quantifies "environmental information on the life cycle of a product and enable comparisons between products fulfilling the same function" (ISO, 2006). This follows the structure and applies a Life-Cycle Assessment approach to the entire Product stage from raw material through manufacturing (A1-A3))

Kompan A/S
 C.F. Tietgens Boulevard 32C
 DK-5220 Odense SØ
 Denmark

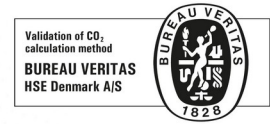

Verification of CO₂ calculation of: Play systems



Data version no. 2023-10-05

The CO₂ calculation and data are in compliance with the principles of a carbon footprint impact according to the GHG protocol (Greenhouse Gas Protocol), Scope 3, cradle to gate related to all individual components in the product category: "Play systems" represented by item no.: PCM200321-0950.

(Scope 3 emissions include emission sources in the upstream and downstream value chain).

Date: 30. October 2023 | Valid until: 30. October 2025

Verified by:

Julie Marie Vejsgaard Larsen, LCA & EPD Consultant

Verification based on report: Validation of CO₂ calculation of 9 categories of Kompan product line, version 1.0, prepared by: Bureau Veritas HSE, Denmark: Julie M. V. Larsen.

Publication date: 30. October 2023

By Bureau Veritas HSE
 www.bureauveritas.dk
 +45 7731 1000



* Max fall height | ** Total height | *** Safety surfacing area

* Max fall height | ** Total height

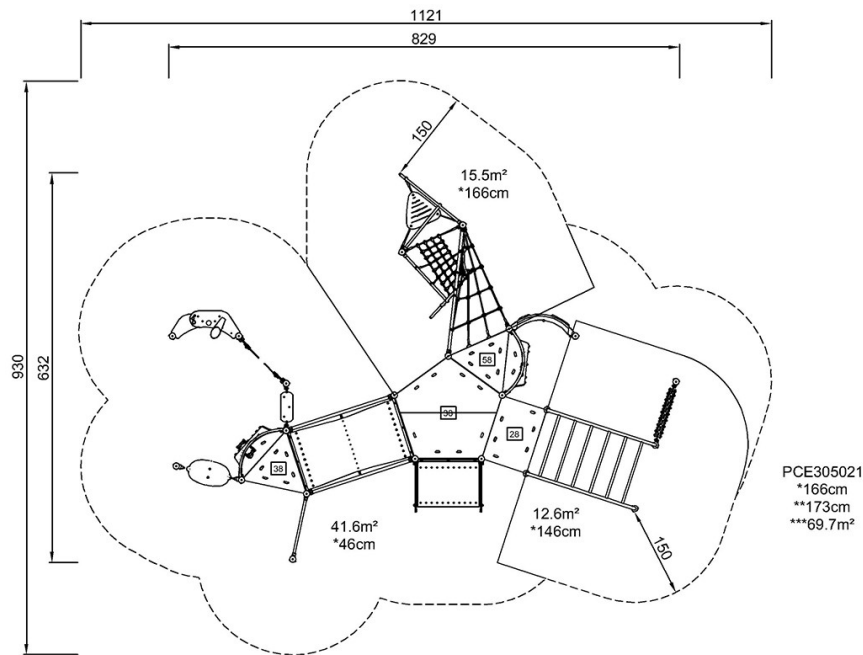

PCE305021
*166cm
**173cm
***69.7m²

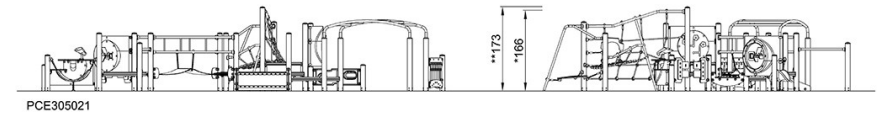

[Click to see TOP VIEW](#)

[Click to see SIDE VIEW](#)