

Penta Climber

PCM81321



Item no. PCM81321-0950	
General Product Information	
Dimensions LxWxH	287x322x253 cm
Age group	6+
Play capacity (users)	8
Color options	



Wow! The Penta Climber attracts children instantly. With its high concentration of challenging activities, the Penta Climber encourages children to play for longer and come back again and again. Its varied climbing features train proprioception and cross-body coordination. These motor skills are fundamental for navigating the world securely

and they also affect reading skills. The Climbing Wall, Pipe Climber and Climbing Pole add challenges for moving up as well as across, training muscles. The Horizontal Net offers a great and transparent destination for breaks and talkative play. The Banister Bars and Fireman's Pole are thrilling egresses, and the jumping down builds bone density. Apart

from all the climbing and gliding, there are plenty of opportunities for socializing and making friends - which adds to play duration.

Penta Climber

PCM81321



Pipe climber

Physical: muscle strength, cross coordination, and spatial awareness when climbing. **Social-Emotional:** encourage socializing when seated on the bars.

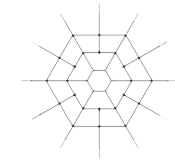

Horizontal spider net

Physical: crawling the net supports cross coordination. **Social-Emotional:** place to meet and hang for many children seated, lying or hanging.



Climbing pole

Physical: cross coordination and muscle strength are trained. **Social-Emotional:** turn-taking and cooperation.



Banister bars

Physical: coordination is supported when going down, as well as arm and core muscles. Landing strengthens bone density, which is built for life in childhood. **Social-Emotional:** turn-taking and risk-taking.



Fireman's pole

Physical: coordination is supported when going down, as well as arm and core muscles. Landing strengthens bone density, which is built for life in early childhood. **Social-Emotional:** turn-taking and risk-taking.



Climbing wall

Physical: develops children's cross coordination, eye-hand coordination, and muscle strength when climbing. **Social-Emotional:** two-sided climb invites cooperation.

Penta Climber

PCM81321



Main posts with hot dip galvanized steel footing are available in different materials: Pressure impregnated pine wood posts. Pre-galvanized inside and outside with powder coated top finish steel posts. Lead free aluminum with color anodized top finish. Greenline TexMade posts of 95% post-consumer recycled PE and textile waste.

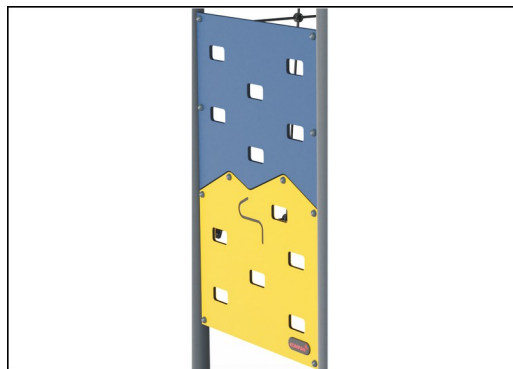

Panels of 19mm EcoCore™. EcoCore™ is a highly durable, eco friendly material, which is not only recyclable after use, but also consists of material produced from +95% recycled post consumer material from food packing waste.



The steel surfaces are hot dip galvanized inside and outside with lead free zinc. The galvanisation has excellent corrosion resistance in outside environments and requires low maintenance.



Ropes of UV-stabilized PES rope strands with inner steel cable reinforcement. The polyester yarn is made from +95% post-consumer materials and is inductively melted onto each strand.

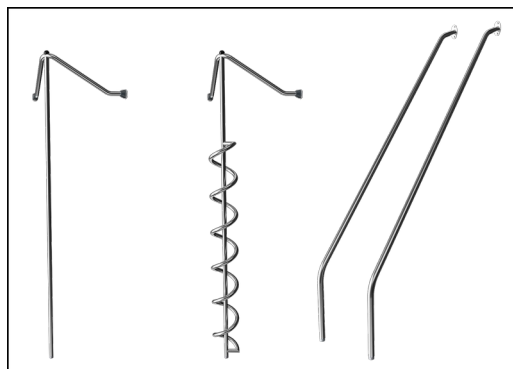

The stainless-steel activities are made of high-quality stainless steel. The steel is cleaned by a total pickling process after manufacturing to ensure a smooth and clean gliding surfaces.



KOMPAN GreenLine versions are designed with ultimate environmentally friendly materials with lowest possible CO2e emission factor. TexMade post, EcoCore™ panels of 95% post-consumer recycled waste and molded PP decks.

Item no. PCM81321-0950

Installation Information

Max. fall height	223 cm
Safety surfacing area	27.3 m ²
Total installation time	10.2
Excavation volume	1.21 m ³
Concrete volume	0.59 m ³
Footing depth (standard)	90 cm
Shipment weight	349 kg
Anchoring options	Surface ✓ In-ground ✓

Warranty Information

EcoCore HDPE	Lifetime
Hot dip galvanized steel	Lifetime
Post	10 years
Ropes & nets	10 years
Spare parts guaranteed	10 years



Sustainability Data

PCM81321



Cradle to Gate A1-A3	Total CO ₂ emission	CO ₂ e/kg	Recycled materials
	kg CO ₂ e	kg CO ₂ e/kg	%
PCM81321-0950	430.98	1.78	74.13
PCM81321-0901	486.60	2.35	65.53

The overall framework applied for these factors is the Environmental Product Declaration (EPD), which quantifies "environmental information on the life cycle of a product and enable comparisons between products fulfilling the same function" (ISO, 2006). This follows the structure and applies a Life-Cycle Assessment approach to the entire Product stage from raw material through manufacturing (A1-A3))

Kompan A/S
 C.F. Tietgens Boulevard 32C
 DK-5220 Odense SØ
 Denmark



Verification of CO₂ calculation of: Freestanding play equipment



Data version no. 2023-10-05

The CO₂ calculation and data are in compliance with the principles of a carbon footprint impact according to the GHG protocol (Greenhouse Gas Protocol), Scope 3, cradle to gate related to all individual components in the product category: "Freestanding play equipment" represented by item no.: GXY916012-3417.

(Scope 3 emissions include emission sources in the upstream and downstream value chain).

Date: 30. October 2023 | Valid until: 30. October 2025

Verified by:

Julie Marie Vejsgaard Larsen, LCA & EPD Consultant

Verification based on report: Validation of CO₂ calculation of 9 categories of Kompan product line, version 1.0, prepared by: Bureau Veritas HSE, Denmark: Julie M. V. Larsen.

Publication date: 30. October 2023

By Bureau Veritas HSE
 www.bureauveritas.dk
 +45 7731 1000



Penta Climber

PCM81321

* Max fall height | ** Total height | *** Safety surfacing area

* Max fall height | ** Total height

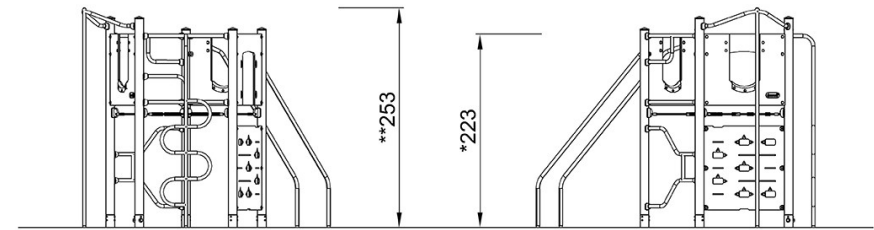
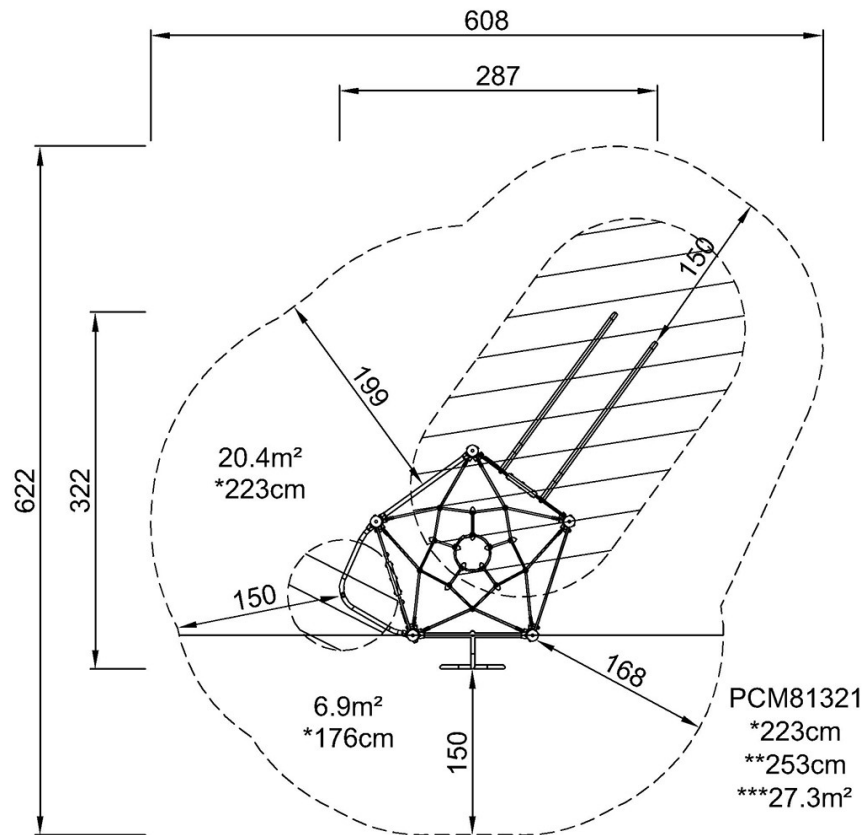

PCM81321

[Click to see TOP VIEW](#)

[Click to see SIDE VIEW](#)