

Two Towers with Bridge

NRO2002



Item no. NRO2002-1001

General Product Information

Dimensions LxWxH	589x300x400 cm
Age group	6+
Play capacity (users)	13
Color options	

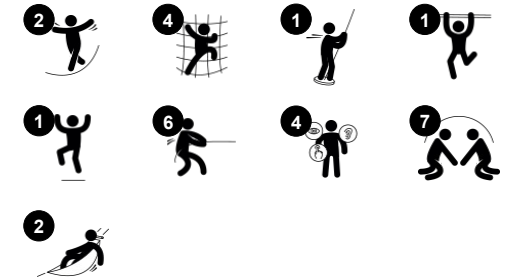

The Two Towers with Bridge has lots of climb and glide variations, so children will want to try it out again and again. They will train their cardio and muscles as they loop the slide and the varied climb access points. The inclined net access is a fun challenge which trains the child's proprioception: the awareness of where the body parts are in space and how much force

and distance it takes to move securely. The rope ladders are even more challenging with their swaying vertical steps. The bridge trains sense of balance, the fundamental motor skill that make children confident when moving and is important for the ability to sit still and concentrate. On the platforms and the bridge, children socialise and learn how to take turns.

The banister bars offer a thrilling way down, training the sense of space and the proprioception.



Two Towers with Bridge

NRO2002



All Organic Robinia products by KOMPAN are made of Robinia wood from sustainable European sources. On request it can be supplied as FSC® Certified (FSC® C004450).



The product/activities are preassembled from the factory to ensure all safety requirements are considered.



Ropes of UV-stabilized PES rope strands with inner steel cable reinforcement. The polyester yarn is made from +95% post-consumer materials and is inductively melted onto each strand.

Item no. NRO2002-1001	
Installation Information	
Max. fall height	200 cm
Safety surfacing area	39.6 m ²
Total installation time	18.0
Excavation volume	2.05 m ³
Concrete volume	0.46 m ³
Footing depth (standard)	100 cm
Shipment weight	959 kg
Anchoring options	In-ground ✓



The stainless-steel activities are made of high-quality stainless steel. The steel is cleaned by a total pickling process after manufacturing to ensure a smooth and clean gliding surfaces.



The Robinia wood can be supplied as untreated raw wood or painted with a brown coloured transparent pigment that maintains the golden wood colour of the wood.



Sustainability Data

NRO2002



Cradle to Gate A1-A3	Total CO ₂ emission	CO ₂ e/kg	Recycled materials
	kg CO ₂ e	kg CO ₂ e/kg	%
NRO2002-1001	436.90	0.57	5.10

The overall framework applied for these factors is the Environmental Product Declaration (EPD), which quantifies "environmental information on the life cycle of a product and enable comparisons between products fulfilling the same function" (ISO, 2006). This follows the structure and applies a Life-Cycle Assessment approach to the entire Product stage from raw material through manufacturing (A1-A3))

Kompan A/S
 C.F. Tietgens Boulevard 32C
 DK-5220 Odense SØ
 Denmark



Verification of CO₂ calculation of: Nature play



Data version no. 2023-10-05

The CO₂ calculation and data are in compliance with the principles of a carbon footprint impact according to the GHG protocol (Greenhouse Gas Protocol), Scope 3, cradle to gate related to all individual components in the product category: "Nature play" represented by item no.: NRO409-0621.

(Scope 3 emissions include emission sources in the upstream and downstream value chain).

Date: 30. October 2023 | Valid until: 30. October 2025

Verified by:

Julie Marie Vejsgaard Larsen, LCA & EPD Consultant

Verification based on report: Validation of CO₂ calculation of 9 categories of Kompan product line, version 1.0, prepared by: Bureau Veritas HSE, Denmark: Julie M. V. Larsen.

Publication date: 30. October 2023

By Bureau Veritas HSE
 www.bureauveritas.dk
 +45 7731 1000



Two Towers with Bridge

NRO2002

* Max fall height | ** Total height | *** Safety surfacing area

* Max fall height | ** Total height

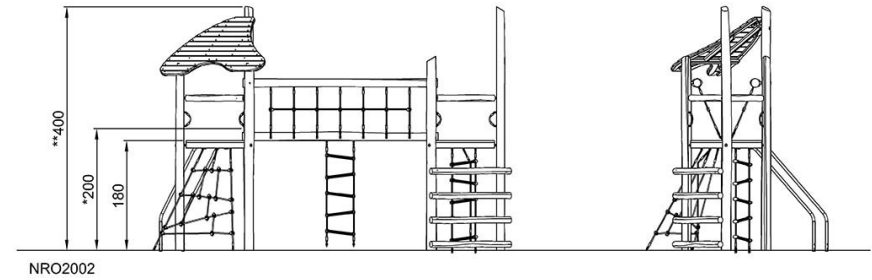
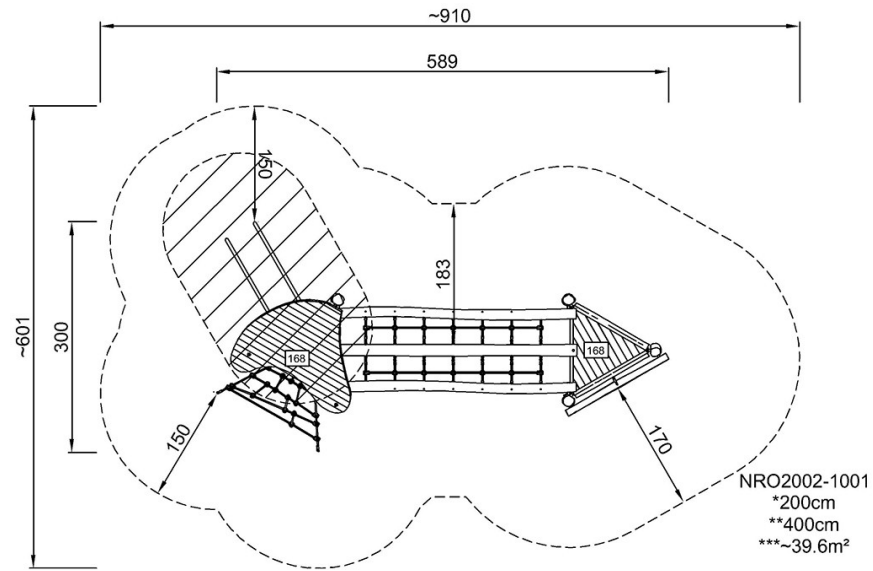

[Click to see TOP VIEW](#)

[Click to see SIDE VIEW](#)