

Dragon Slide

PCM304



Sliding is a favourite playground activity that attracts children to be active and playful in a thrilling way. This sturdy slide with dragon theme will delight children and encourage them to be brave and enthusiastic at the playground, for hours of imaginative and active play. When children slide they train their core muscles, sitting upright while sliding down. This

stimulates their trunk stability, important for avoiding back and neck pains – a growing problem in children due to sedentary lifestyles. Sliding additionally train the child's sense of balance and spatial understanding. They are important motor skills and thus fundamental in physical confidence in the child. The steps are ergonomically appropriate for little hands,

adding a feeling of confidence to the climb.

Item no. PCM304-0601	
General Product Information	
Dimensions LxWxH	67x294x195 cm
Age group	2+
Play capacity (users)	2
Colour options	

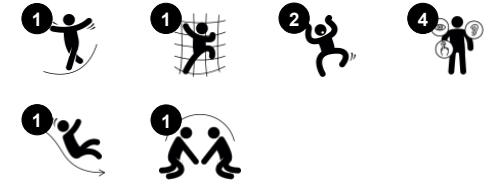

Dragon Slide

PCM304



Stair ladder

Physical: cross coordination is used, supporting the cooperation of the left and right halves of the brain, which. For young children.



Slide

Physical: develops spatial awareness, sense of balance and trains core muscles when sitting upright going down. **Social-Emotional:** empathy stimulated by turn-taking. **Cognitive:** young children develop their understanding of space, speed and distances when sliding down.

Dragon Slide

PCM304



Panels of 19mm EcoCore™. EcoCore™ is a highly durable, eco-friendly material, which is not only recyclable after use but also consists of a core produced from 100% recycled material.

Steps are made of extruded aluminium with a non-skid surface. Aluminium has high corrosion resistance; ensuring the steps are highly durable.



The slide can be chosen in different colours including yellow or grey colour. Slide is made of moulded PE.

Item no. PCM304-0601	
Installation Information	
Max. fall height	118 cm
Safety surfacing area	17.8 m ²
Total installation time	4.2
Excavation volume	0.27 m ³
Concrete volume	0.00 m ³
Footing depth (standard)	60 cm
Shipment weight	113 kg
Anchoring options	In-ground ✓
Warranty Information	
EcoCore HDPE	Lifetime
Galvanised Steel	Lifetime
Spare Parts Guarantee	10 years



The steel surfaces are hot-dip galvanised inside and outside with lead-free zinc. The galvanisation has excellent corrosion resistance in outside environments and requires low maintenance.



Sustainability Data

PCM304



Cradle to Gate A1-A3	Total CO ₂ emission	CO ₂ e/kg	Recycled materials
	kg CO ₂ e	kg CO ₂ e/kg	%
PCM304-0601	151.18	1.65	56.68

The overall framework applied for these factors is the Environmental Product Declaration (EPD), which quantifies "environmental information on the life cycle of a product and enable comparisons between products fulfilling the same function" (ISO, 2006). This follows the structure and applies a Life-Cycle Assessment approach to the entire Product stage from raw material through manufacturing (A1-A3))

Kompan A/S
 C.F. Tietgens Boulevard 32C
 DK-5220 Odense SØ
 Denmark



Verification of CO₂ calculation of: Freestanding play equipment



Data version no. 2023-10-05

The CO₂ calculation and data are in compliance with the principles of a carbon footprint impact according to the GHG protocol (Greenhouse Gas Protocol), Scope 3, cradle to gate related to all individual components in the product category: "Freestanding play equipment" represented by item no.: GXY916012-3417.

(Scope 3 emissions include emission sources in the upstream and downstream value chain).

Date: 30. October 2023 | Valid until: 30. October 2025

Verified by:

Julie Marie Vejsgaard Larsen, LCA & EPD Consultant

Verification based on report: Validation of CO₂ calculation of 9 categories of Kompan product line, version 1.0, prepared by: Bureau Veritas HSE, Denmark: Julie M. V. Larsen.

Publication date: 30. October 2023

By Bureau Veritas HSE
 www.bureauveritas.dk
 +45 7731 1000



Dragon Slide

PCM304

* Max fall height | ** Total height | *** Safety surfacing area

* Max fall height | ** Total height

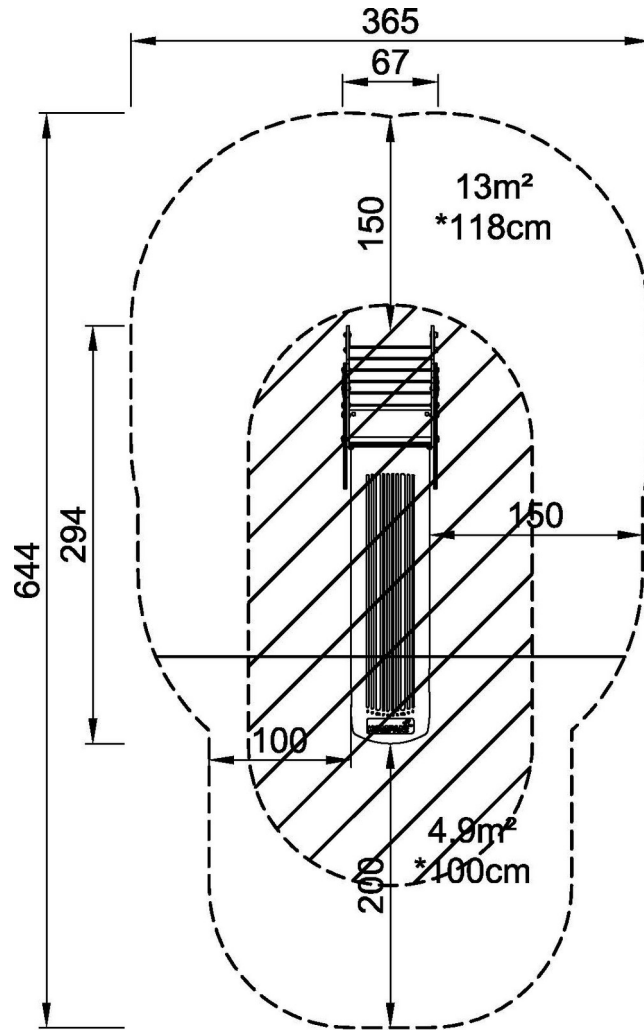

PCM304
*118cm
**195cm
***19.3m²

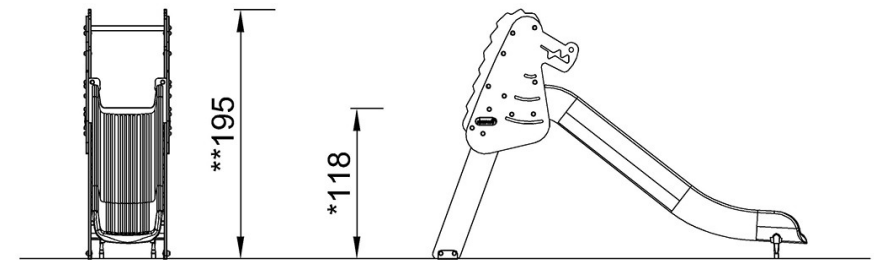

PCM304

[Click to see TOP VIEW](#)

[Click to see SIDE VIEW](#)