

# Excavator

NRO524



Item no. NRO524-0801

## General Product Information

Dimensions LxWxH	124x23x80 cm
Age group	2+
Play capacity (users)	1
Color options	 



The Excavator is a magnet for construction play. It attracts builders in a wide age span to dig, transport and turn sand. It will absorb children in play, again and again. When digging, the children need to navigate the handles and shovel. This is a huge task on coordination as well as logical thinking skills. When the sand needs to be re-located, the

children will have to use their feet to turn the Excavator up to 360 degrees, to the desired destination. The fine motor and gross motor skill training going into this is considerable. The Excavator can accommodate solitary as well as social play, such as turn-taking and negotiation. These skills can be hard to teach, but children acquire them when they do construction play.

These skills are fundamental for the ability to form friendships.



# Excavator

NRO524



## Seat

**Social-Emotional:** possibility for being seated adds ease to shoveling, making it a controllable experience



## Shovel module

**Physical:** cross coordination to control the shovel thereby developing cooperation of left and right brain half which is necessary for academic skills such as reading. **Cognitive:** navigating the shovel, filling and emptying it takes refined logical thinking. **Creative:** sand and construction play is encouraged, leaving your mark on the playground.



## Handhold

**Physical:** the vertical handgrips ensure a firm grip at different heights, necessary for rocking intensely. This trains hand and arm muscles.

# Excavator

NRO524



All Organic Robinia products by KOMPAN are made of Robinia wood from sustainable European sources. On request it can be supplied as FSC® Certified (FSC® C004450).



The stainless-steel activities are made of high-quality stainless steel. The steel is cleaned by a total pickling process after manufacturing to ensure a smooth and clean gliding surfaces.



Handholds are made of UV stabilised conditioned injection-moulded polyamide (PA6) a great protection to all weather conditions. The ergonomically shaped handles guarantee a good and pleasant grip for all users.

Item no. NRO524-0801

## Installation Information

Max. fall height	37 cm
Safety surfacing area	19.0 m <sup>2</sup>
Total installation time	1.5
Excavation volume	0.29 m <sup>3</sup>
Concrete volume	0.00 m <sup>3</sup>
Footing depth (standard)	80 cm
Shipment weight	96 kg
Anchoring options	In-ground ✓



# Sustainability Data

NRO524



Cradle to Gate A1-A3	Total CO <sub>2</sub> emission	CO <sub>2</sub> e/kg	Recycled materials
	kg CO <sub>2</sub> e	kg CO <sub>2</sub> e/kg	%
<b>NRO524-0801</b>	250.37	3.76	48.44

The overall framework applied for these factors is the Environmental Product Declaration (EPD), which quantifies "environmental information on the life cycle of a product and enable comparisons between products fulfilling the same function" (ISO, 2006). This follows the structure and applies a Life-Cycle Assessment approach to the entire Product stage from raw material through manufacturing (A1-A3))

**Kompan A/S**  
 C.F. Tietgens Boulevard 32C  
 DK-5220 Odense SØ  
 Denmark



## Verification of CO<sub>2</sub> calculation of: Nature play



Data version no. 2023-10-05

The CO<sub>2</sub> calculation and data are in compliance with the principles of a carbon footprint impact according to the GHG protocol (Greenhouse Gas Protocol), Scope 3, cradle to gate related to all individual components in the product category: "Nature play" represented by item no.: NRO409-0621.

(Scope 3 emissions include emission sources in the upstream and downstream value chain).

**Date: 30. October 2023 | Valid until: 30. October 2025**

**Verified by:**

Julie Marie Vejsgaard Larsen, LCA & EPD Consultant

Verification based on report: Validation of CO<sub>2</sub> calculation of 9 categories of Kompan product line, version 1.0, prepared by: Bureau Veritas HSE, Denmark: Julie M. V. Larsen.

**Publication date: 30. October 2023**

**By Bureau Veritas HSE**  
 www.bureauveritas.dk  
 +45 7731 1000



# Excavator

NRO524

\* Max fall height | \*\* Total height | \*\*\* Safety surfacing area

\* Max fall height | \*\* Total height

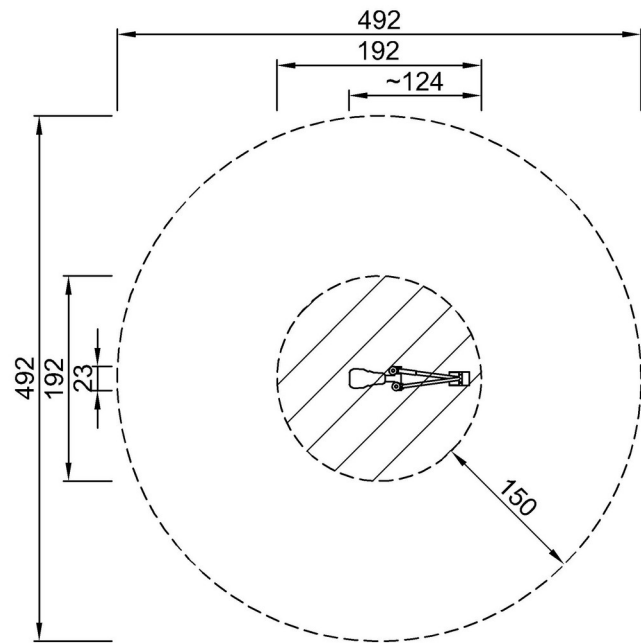

NRO524  
\*37cm  
\*\*80cm  
\*\*\*19m<sup>2</sup>

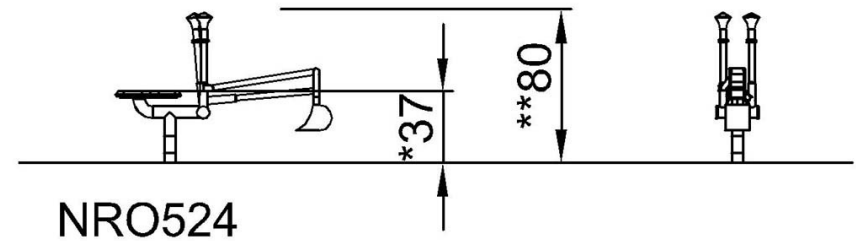

NRO524

[Click to see TOP VIEW](#)

[Click to see SIDE VIEW](#)