

# Super Combi 1, Supervised

FSW251

**KOMPANI**  
Let's play



Item no. FSW25100-0900	
<b>General Product Information</b>	
Dimensions LxWxH	533x550x325 cm
Age group	13+
Play capacity (users)	13
Color options	



The Super Combi 1 Gated has the same options as the standard Super Combi 1 but also has a connector for battle rope, a connector for a boxing bag, and a station for barbell exercises. This item is intended for supervised or gated areas such as sports or fitness clubs, as these loose items do not satisfy safety standards for public

places.<br>Supervised products are only for areas that are gated or fenced-off, like fitness clubs with supervision or gated communities.



# Super Combi 1, Supervised

FSW251



Post are made of  $\text{Ø}101.6 \times 2\text{mm}$ , pre-galvanized carbon steel and powder coated, a great protection to all conditions.

Item no. FSW25100-0900

### Installation Information

Max. fall height	200 cm
Safety surfacing area	46.3 m <sup>2</sup>
Total installation time	11.5
Excavation volume	0.83 m <sup>3</sup>
Concrete volume	0.50 m <sup>3</sup>
Footing depth (standard)	90 cm
Shipment weight	609 kg
Anchoring options	In-ground ✓ Surface ✓



# Sustainability Data

FSW251



Cradle to Gate A1-A3	Total CO <sub>2</sub> emission	CO <sub>2</sub> e/kg	Recycled materials
	kg CO <sub>2</sub> e	kg CO <sub>2</sub> e/kg	%
<b>FSW25100-0900</b>	948.55	2.41	56.70

The overall framework applied for these factors is the Environmental Product Declaration (EPD), which quantifies "environmental information on the life cycle of a product and enable comparisons between products fulfilling the same function" (ISO, 2006). This follows the structure and applies a Life-Cycle Assessment approach to the entire Product stage from raw material through manufacturing (A1-A3))

**Kompan A/S**  
 C.F. Tietgens Boulevard 32C  
 DK-5220 Odense SØ  
 Denmark



## Verification of CO<sub>2</sub> calculation of: Fitness



Data version no. 2023-10-05

The CO<sub>2</sub> calculation and data are in compliance with the principles of a carbon footprint impact according to the GHG protocol (Greenhouse Gas Protocol), Scope 3, cradle to gate related to all individual components in the product category: "Fitness" represented by item no.: FAZ10100-0900.

(Scope 3 emissions include emission sources in the upstream and downstream value chain).

**Date: 30. October 2023 | Valid until: 30. October 2025**

**Verified by:**

Julie Marie Vejsgaard Larsen, LCA & EPD Consultant

Verification based on report: Validation of CO<sub>2</sub> calculation of 9 categories of Kompan product line, version 1.0, prepared by: Bureau Veritas HSE, Denmark: Julie M. V. Larsen.

**Publication date: 30. October 2023**

**By Bureau Veritas HSE**  
 www.bureauveritas.dk  
 +45 7731 1000



# Super Combi 1, Supervised

FSW251

\* Max fall height | \*\* Total height | \*\*\* Safety surfacing area

\* Max fall height | \*\* Total height

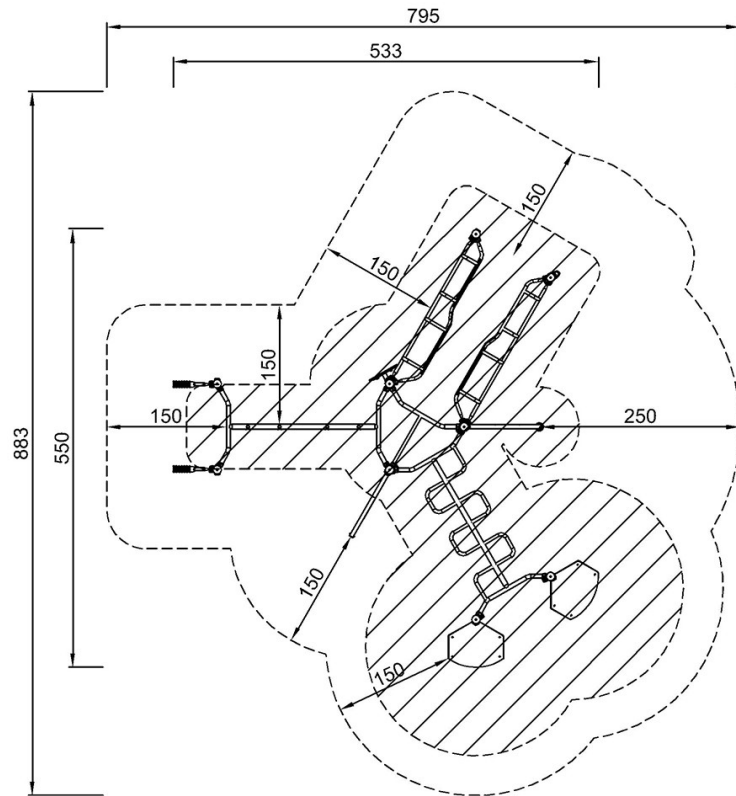

FSW25100  
\*200cm  
\*\*325cm  
\*\*\*46.3m<sup>2</sup>

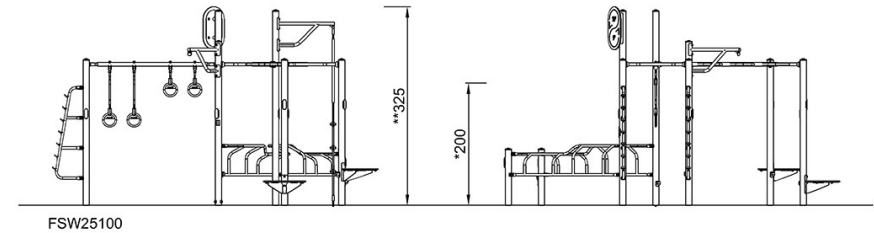

[Click to see TOP VIEW](#)

[Click to see SIDE VIEW](#)