

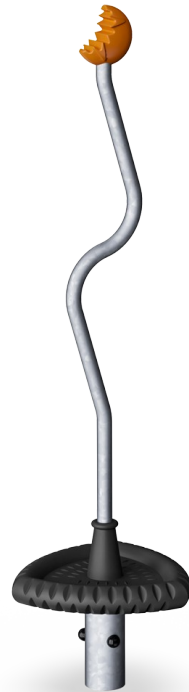

Spica 3

GXY8016



Item no. GXY801621-3717	
General Product Information	
Dimensions LxWxH	44x45x169 cm
Age group	6+
Play capacity (users)	1
Colour options	



Spica is a uniquely designed, delightful, challenging piece of rotating playground equipment that can be independently placed along a pedestrian street, by a sports centre or within a shopping district. It can also be included as part of a group of playground equipment. The three models have different designs and react in different ways to the

movement of the child. It is therefore necessary to experiment with its movement and one's centre of gravity in order to master Spica's rotations.



Spica 3

GXY8016



Curved pole

Physical: more gripping or leaning support points when standing, sitting, hanging holding tight and spinning.

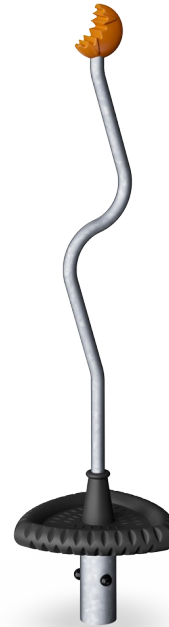

Triangle seat

Social-Emotional: turn-taking, cooperation, socializing.



Internal ball-bearing spinner

Cognitive: logical thinking, figuring out how to make the spinner work with gravity, not against it.



Rotation

Physical: pushing or pulling it into motion, children use their muscle strength and strengthen their cardio. The rotation develops the sense of balance and space when enjoying the ride. **Social-Emotional:** listening and negotiating how slow or fast to go, children develop their empathy and cooperation skills.

Spica 3

GXY8016



The Spica bearings are installed in a one-piece design bearing house with integrated drain holes for water passage. The two large steel bearings are fully closed and lifetime lubricated.



The unique GALAXY super triangle deck plate has an inner core of galvanised steel and soft outer layer of PUR rubber. The rounded edges has a non-skid pattern for safe play.



The coloured top is made of injection moulded high quality nylon (PA6) which is UV stabilised to ensure long life time. The two component design is assembled with steel pins around the steel pipe.



The steel surfaces are hot dip galvanised inside and outside with lead free zinc. The galvanisation has excellent corrosion resistance in outside environments and requires low maintenance.

Item no. GXY801621-3717	
Installation Information	
Max. fall height	100 cm
Safety surfacing area	9.7 m ²
Total installation time	1.6
Excavation volume	0.38 m ³
Concrete volume	0.30 m ³
Footing depth (standard)	90 cm
Shipment weight	60 kg
Anchoring options	In-ground ✓ Surface ✓
Warranty Information	
Bearing construction	5 years
Hardware	10 years
Hot dip galvanised steel	Lifetime
Spare parts guaranteed	10 years



Sustainability Data

GXY8016



Cradle to Gate A1-A3	Total CO ₂ emission	CO ₂ e/kg	Recycled materials
	kg CO ₂ e	kg CO ₂ e/kg	%
GXY801621-3717	110.76	2.89	35.20

The overall framework applied for these factors is the Environmental Product Declaration (EPD), which quantifies "environmental information on the life cycle of a product and enable comparisons between products fulfilling the same function" (ISO, 2006). This follows the structure and applies a Life-Cycle Assessment approach to the entire Product stage from raw material through manufacturing (A1-A3))

Kompan A/S
 C.F. Tietgens Boulevard 32C
 DK-5220 Odense SØ
 Denmark



Verification of CO₂ calculation of: Freestanding play equipment



Data version no. 2023-10-05

The CO₂ calculation and data are in compliance with the principles of a carbon footprint impact according to the GHG protocol (Greenhouse Gas Protocol), Scope 3, cradle to gate related to all individual components in the product category: "Freestanding play equipment" represented by item no.: GXY916012-3417.

(Scope 3 emissions include emission sources in the upstream and downstream value chain).

Date: 30. October 2023 | Valid until: 30. October 2025

Verified by:

Julie Marie Vejsgaard Larsen, LCA & EPD Consultant

Verification based on report: Validation of CO₂ calculation of 9 categories of Kompan product line, version 1.0, prepared by: Bureau Veritas HSE, Denmark: Julie M. V. Larsen.

Publication date: 30. October 2023

By Bureau Veritas HSE
 www.bureauveritas.dk
 +45 7731 1000



Spica 3

GXY8016

* Max fall height | ** Total height | *** Safety surfacing area

* Max fall height | ** Total height

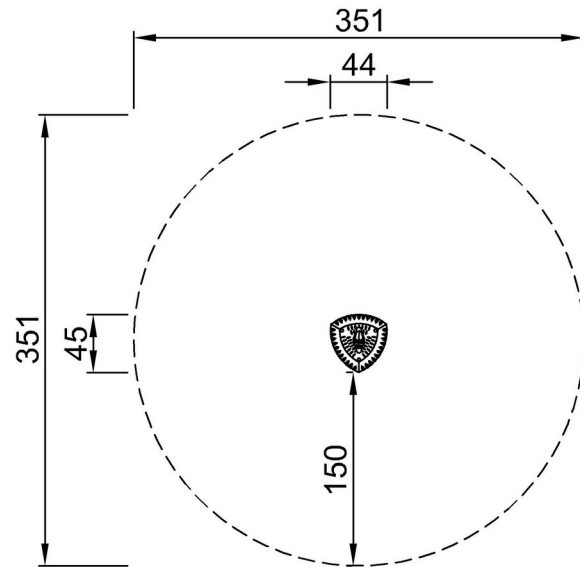

GXY8016XX-xx17
*100cm
**169cm
***9.7m²

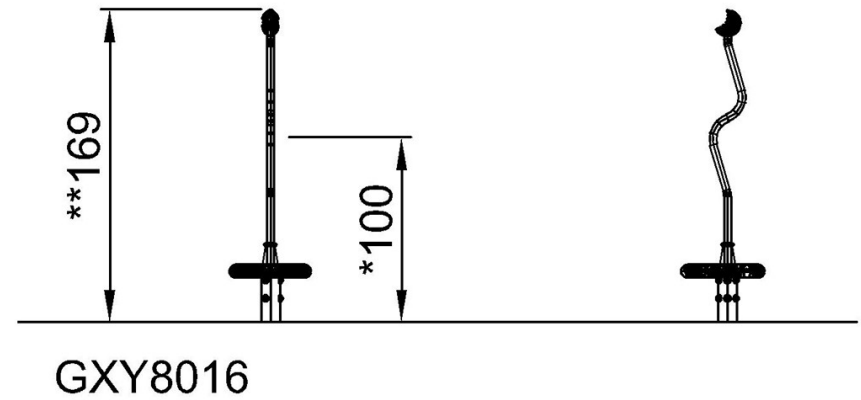

[Click to see TOP VIEW](#)

[Click to see SIDE VIEW](#)