

Wooden Rope Climber M

KPW250401

KOMPANI



Item no. KPW250401-0901	
General Product Information	
Dimensions LxWxH	404x188x282 cm
Age group	4+
Play capacity (users)	13
Colour options	

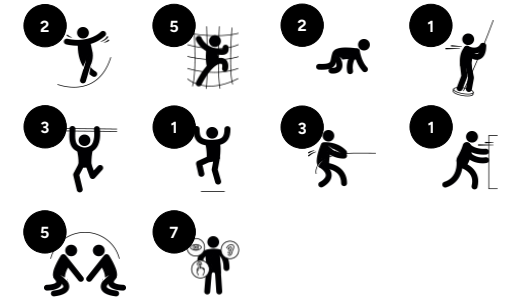

The Wooden Rope Climber immediately attracts children to the dense activity hub. Thanks to the varied climbing activities and route opportunity, all children have a chance of doing something. The fireman's pole provides a thrilling destination. The openness in design also invites conversation and social interaction across the Climber. This supports children's

socio-emotional development. With its combination of activities, the Climbing Structure stimulates children's cross-coordination, strength and bone density. All of these abilities are built for life in childhood.

Wooden Rope Climber M

KPW250401



Climbing net

Physical: children develop cross-body coordination and muscle strength when climbing. The big meshes allow for climbing and crawling through, supporting proprioception and spatial awareness. **Social-Emotional:** the big meshes allow for more children to sit together and talk.

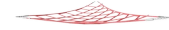

Horizontal net

Physical: cross coordination is developed when climbing over and sense of space when looking down. **Social-Emotional:** space for socializing and bouncy breaks.



Somersault bar

Physical: develop balance and core when hanging from knees. Arm, leg and core muscles are developed when climbing up, somersaulting around. Balance and spatial awareness are strengthened. **Social-Emotional:** meeting, socializing and turn-taking when climbing up and down via bar.



Supportive handholds

Physical: handhold provides good grip for less confident climbers. Pulling yourself up and in trains upper body muscles.



Balance beam

Physical: trains the sense of balance, fundamental for all other motor skills that makes it possible to navigate the world confidently and securely. **Social-Emotional:** turn-taking skills and negotiation when crossing each other on the beam. Room for a seated rest and exchange.



Fireman's pole

Physical: coordination is supported when going down, as well as arm and core muscles. Landing strengthens bone density, which is built for life in early childhood. **Social-Emotional:** turn-taking and risk-taking. **Cognitive:** young children develop their understanding of space, speed and distances when gliding down fast.

Wooden Rope Climber M

KPW250401

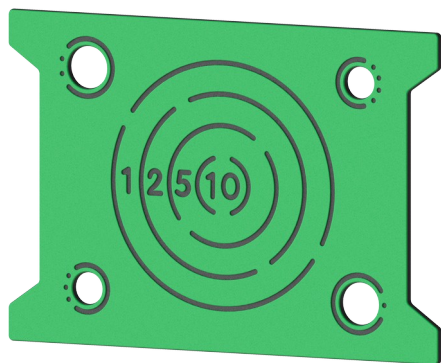

Panels of 19mm CircularHDPE. CircularHDPE is a highly durable, eco-friendly material, which is not only recyclable after use, but also consists of material produced from +95% recycled post-consumer material from food packing waste.

The main tower posts are available in two types of material: European pine wood posts, pressure impregnated Class 3 according to EN335 (Equivalent to NTR Class AB). Aluminum post t=2mm with anodized surface treatment. Base material EN AW-6060 T66.

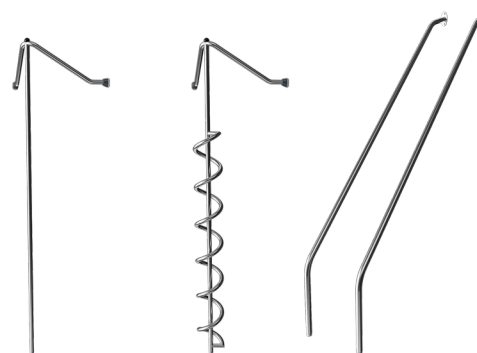

The stainless-steel activities are made of high-quality stainless steel. The steel is cleaned by a total pickling process after manufacturing to ensure a smooth and clean gliding surfaces.

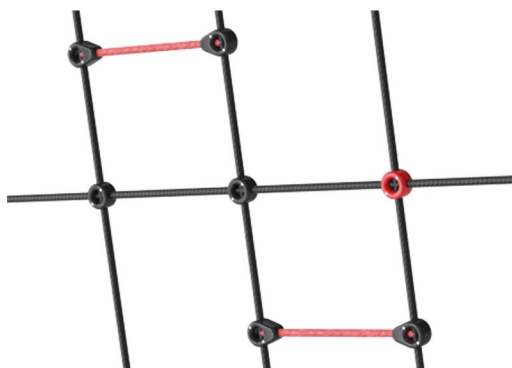

Ropes of UV-stabilized PES rope strands with inner steel cable reinforcement. The polyester yarn is made from +95% post-consumer materials and is inductively melted onto each strand.

Item no. KPW250401-0901

Installation Information

Max. fall height	148 cm
Safety surfacing area	26,5 m ²
Total installation time	7,6 hours
Excavation volume	0,99 m ³
Concrete volume	0,50 m ³
Footing depth (standard)	90 cm
Shipment weight	245 kg
Anchoring options	In-ground ✓ Surface ✓

Warranty Information

Pinewood	10 years
Aluminum	15 years
CircularHDPE	Lifetime
Ropes & nets	10 years
Spare parts guaranteed	10 years

**EN
1176**
compliant

Sustainability Data

KPW250401



Independent review certificate

Kompan A/S
C. F. Tietgens Blvd. 32C, 5220 Odense SØ

Bureau Veritas hereby attests that the CO₂e-calculations (covering materials, processing, waste and transport) done by Kompan for "Nature Play", meet the requirements set by the listed standard.

Kompan A/S uses a selection of EPDs and emission factors from the Life Cycle Assessment database Ecoinvent 3.11. These values are reported as kg CO₂e, with all other impact categories excluded in line with the scope of ISO 14067:2018. The emission factors cover, material use, manufacturing processes, transport to Kompan, and electricity used during manufacturing. The presented emissions fall under GHG Protocol scope 3 emissions. Scope 1 and 2 are not presented. Scope 3 emissions include emission sources in the upstream value chain of a company, downstream emissions are excluded in this analysis.

Method: ISO 14067:2018 using GHG protocol guidance documents, reported as kg CO₂e.

Object

The verification has been done on the one pager "NRO40901-0601" version: 27-10-2025. The supporting documentation "KOMPAN data_updated emissions factors_2025_V2" and "Emissions factors, EPD's and ecoinvent 3.11_2025" was also reviewed and approved.

Declaration

The verification has been completed as a critical review with a limited assurance. I hereby confirm that nothing has come to the reviewer's attention which would lead to conclude that the study does not give an accurate depiction or isn't completed following method of the CO₂e calculation, the requirements of ISO 14067:2018, and 14071:2024, in the above referenced documentation.

Note: This verification only covers calculation elements according to method described in ISO 14067:2018 and may not be seen as a Life Cycle Assessment according to ISO 14067:2018.

Ref.: Kompan_Verification report 2025, 28-10-2025

Date of certificate: 29-10-2025

Expire date: 29-10-2027

Verified by: Julie Marie Vejsgaard Larsen, Environmental Auditor

Signature:

Cradle to Gate A1-A3	Total CO ₂ emission	CO ₂ e/kg	Recycled material
	kg CO ₂ e	kg CO ₂ e/kg	%
KPW250401-0901	477,15	2,68	27,41

The overall framework applied for these factors is the Environmental Product Declaration (EPD), which quantifies "environmental information on the life cycle of a product and enable comparisons between products fulfilling the same function" (ISO, 2006). This follows the structure and applies a Life-Cycle Assessment approach to the entire Product stage from raw material through manufacturing (A1-A3))

Wooden Rope Climber M

KPW250401

* Max fall height | ** Total height | *** Safety surfacing area

* Max fall height | ** Total height

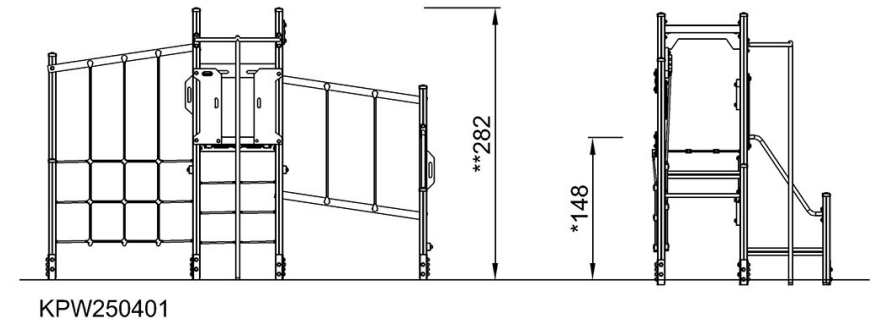
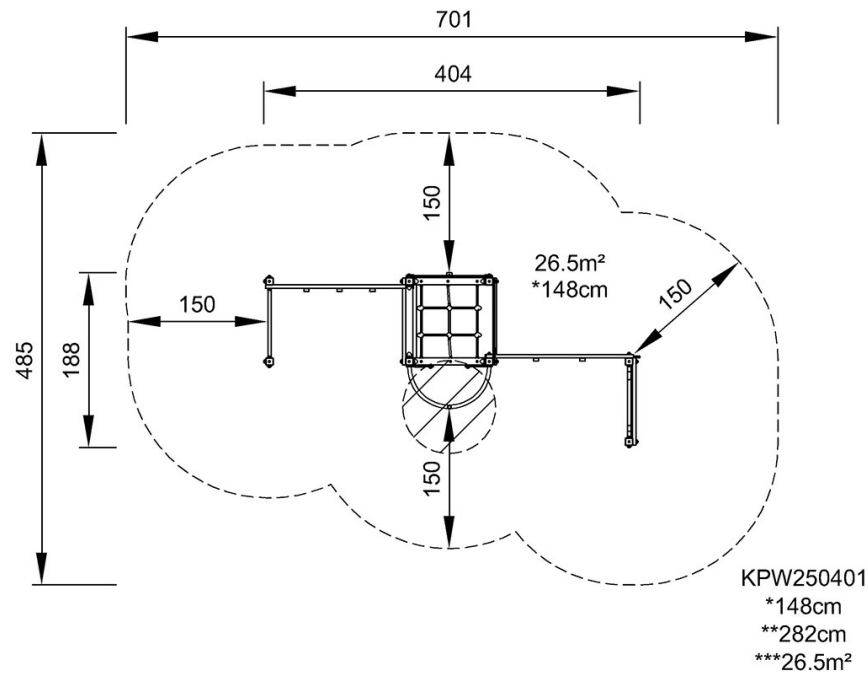

[Click to see TOP VIEW](#)

[Click to see SIDE VIEW](#)