

Tower Slide 1.4m high

NRO306

KOMPANI
Let's play



The Tower Slide appeals immensely to children. With its climb and slide variation, children will try it out again, training cardio and muscles as they loop the slide and the varied climb accesses. The inclined net access is a fun challenge to climb, and it trains the child's proprioception: the automatized awareness of where the body parts are in space and how

much force and distance it takes to move securely. The sturdy stair-way is an even more challenging with its chunky-grip, vertical steps. The platform offers a nice view. The slide is an all-time favorite, tickling the stomach all way down. When children slide, they train their core muscles, sitting upright while sliding down. This stimulates trunk stability, important for avoiding

back and neck pains – a growing problem in children due to sedentary lifestyles. So playground play and the Tower Slide play a fun-role in children's health.

Item no. NRO306-1001

General Product Information

Dimensions LxWxH	386x224x359 cm
Age group	4+
Play capacity (users)	7
Color options	

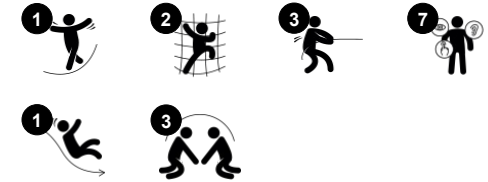

Tower Slide 1.4m high

NRO306



The stainless-steel slides with one-piece slide bed are made of high-quality stainless-steel AISI 304.



All Organic Robinia products by KOMPAN are made of Robinia wood from sustainable European sources. On request it can be supplied as FSC® Certified (FSC® C004450).



Slide interface panel of 19mm EcoCore™. EcoCore™ is a highly durable, eco-friendly material, which is not only recyclable after use, but is also made of +95% recycled post-consumer material from e.g., food packing waste in both core and colorful outer layer.



Nets and ropes are made of UV-stabilised PA with inner steel cable reinforcement. The rope is induction treated in order to create a strong connection between steel and rope which leads to good wear resistance.

Item no. NRO306-1001	
Installation Information	
Max. fall height	140 cm
Safety surfacing area	25.8 m ²
Total installation time	9.3
Excavation volume	0.99 m ³
Concrete volume	0.23 m ³
Footing depth (standard)	100 cm
Shipment weight	470 kg
Anchoring options	In-ground ✓ Surface ✓



Sustainability Data

NRO306



Cradle to Gate A1-A3	Total CO ₂ emission	CO ₂ e/kg	Recycled materials
	kg CO ₂ e	kg CO ₂ e/kg	%
NRO306-1001	316.70	0.94	11.60

The overall framework applied for these factors is the Environmental Product Declaration (EPD), which quantifies "environmental information on the life cycle of a product and enable comparisons between products fulfilling the same function" (ISO, 2006). This follows the structure and applies a Life-Cycle Assessment approach to the entire Product stage from raw material through manufacturing (A1-A3))

Kompan A/S
 C.F. Tietgens Boulevard 32C
 DK-5220 Odense SØ
 Denmark



Verification of CO₂ calculation of: Nature play



Data version no. 2023-10-05

The CO₂ calculation and data are in compliance with the principles of a carbon footprint impact according to the GHG protocol (Greenhouse Gas Protocol), Scope 3, cradle to gate related to all individual components in the product category: "Nature play" represented by item no.: NRO409-0621.

(Scope 3 emissions include emission sources in the upstream and downstream value chain).

Date: 30. October 2023 | Valid until: 30. October 2025

Verified by:

Julie Marie Vejsgaard Larsen, LCA & EPD Consultant

Verification based on report: Validation of CO₂ calculation of 9 categories of Kompan product line, version 1.0, prepared by: Bureau Veritas HSE, Denmark: Julie M. V. Larsen.

Publication date: 30. October 2023

By Bureau Veritas HSE
 www.bureauveritas.dk
 +45 7731 1000



Tower Slide 1.4m high

NRO306

* Max fall height | ** Total height | *** Safety surfacing area

* Max fall height | ** Total height

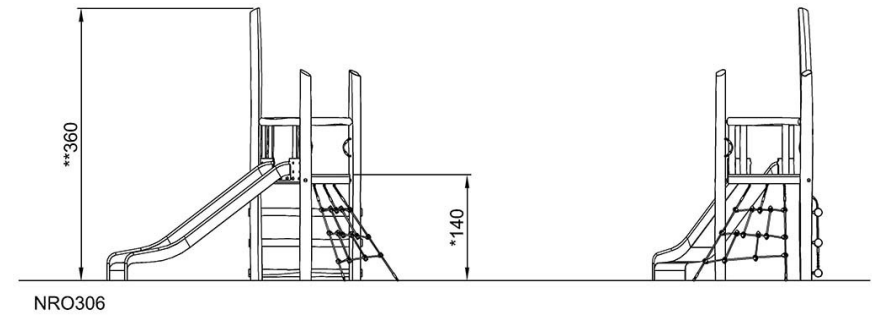
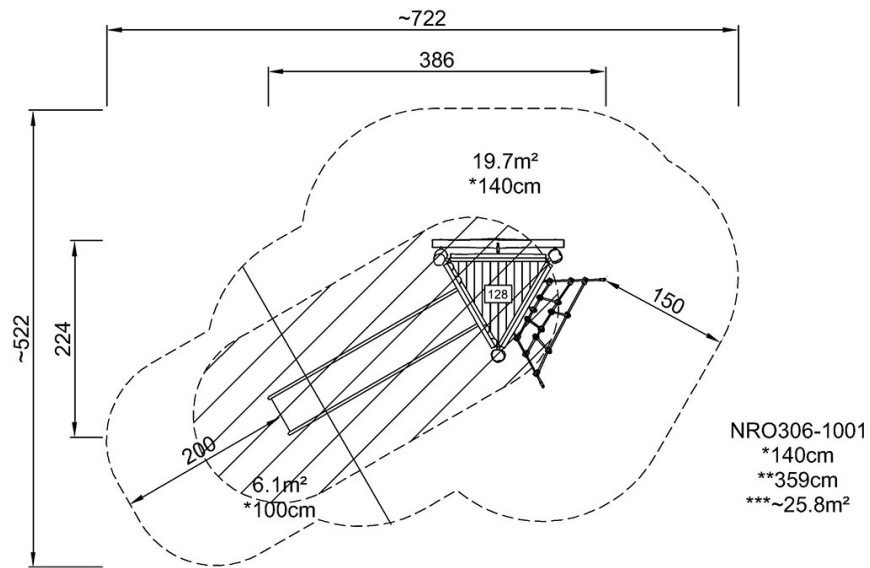

[Click to see TOP VIEW](#)

[Click to see SIDE VIEW](#)