

Mountaineer

PCE205221

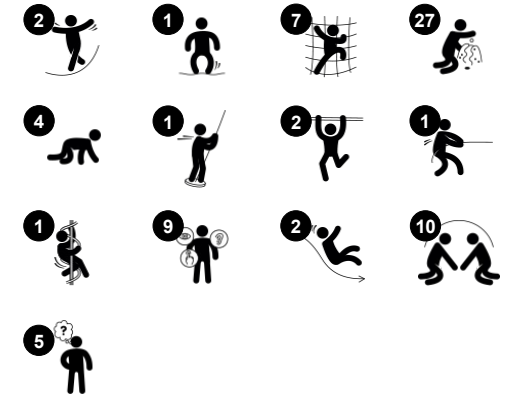

Item no. PCE205221-0603	
General Product Information	
Dimensions LxWxH	738x552x410 cm
Age group	2 - 5
Play capacity (users)	35
Colour options	● ● ●



The Mountaineer attracts toddlers again and again with its spacious and varied play events. There is a choice of physical activity, social activity and cognitive stimulation, for a range of users. The varied climbing possibilities - a membrane climber, horizontal net, play panel climbing wall and stairway - offer play on different levels with challenges, and train cross-

coordination and muscles. The bouncy membrane climber is a play event that responds to the child's movements, adding challenge and fun. The double slide is a social and thrilling event, that also trains the sense of balance and the core muscles. The vast amount of play panels and the talking tubes are attractive play exploration opportunities, that

train agility as well as logical thinking with their many moveable and sound elements. There is varied play for all.

Mountaineer

PCE205221

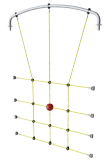

Climbing net

Physical: children train cross-body coordination and muscle strength. The big meshes allow for climbing and crawling through, training proprioception and spatial awareness. **Social-Emotional:** the big meshes allow for more children being seated together, sharing.



Changeable sand funnel

Social-Emotional: supports cooperation and turn-taking as children pour water or materials into the funnel. **Cognitive:** the passing of materials through funnels develops children's logical thinking, for younger children the understanding of object permanence: that materials do not vanish, but run through. **Creative:** the sand funnel can be turned, creating new directions of dispensing materials.



Membrane climber

Physical: cross coordination and muscle strength when climbing up the bouncy, rubbery membrane climber, assisted by climbing cleats or just the hands. Gliding down supports spatial awareness. **Social-Emotional:** the two rows of cleats allow for parallel play and cooperation. **Cognitive:** the two rows of cleats invite rules play and competition.



Bubble Window

Social-Emotional: invites interaction between outside and inside. **Cognitive:** distorts the sound of the voice, developing logical thinking.



Curly climber

Physical: coordination and proprioception are supported when placing arms and legs correctly for going down. Sense of balance when rotating. Arm muscles for holding tight. **Social-Emotional:** empathy stimulated by turn-taking. **Cognitive:** logical thinking when placing arms and legs right for rotating downwards.



Flower panel

Social-Emotional: invites cooperation due to the two-sidedness and provides for parallel play. **Cognitive:** stimulates cause and effect understanding and logical thinking: making sounds when running flower through vertical grooves. **Creative:** children can leave their mark, placing the flowers in different positions.



Xylophone music panel

Social-Emotional: invites social interaction and co-creation for more children, on both sides. **Cognitive:** understanding of cause and effect when striking tubes and creating sound. **Creative:** the creation of different intensity and tonality stimulates creative skills.

Mountaineer

PCE205221



The Curved ELEMENTS panels are moulded of UV stabilised recyclable PE using 33% post-consumer recycled material. With multiple options for in-build play features that also ensures a strong panel solution. Straight panels are made of KOMPAN 19mm HDPE EcoCore™ which is a highly durable, ecofriendly and recyclable material made from +95% PCM.

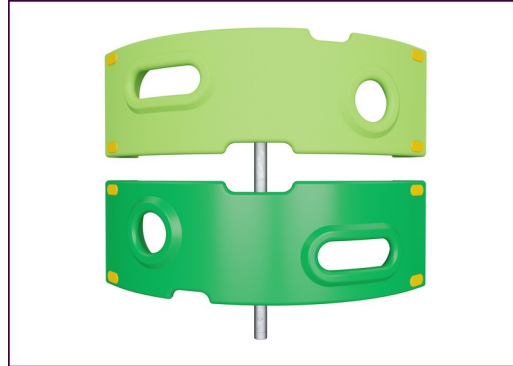

The climbing elements displayed are moulded from 33% post-consumer recycled materials in one piece, with a minimum 5mm wall thickness. The climbing elements are made of recyclable PE which has a high impact resistance across a wide temperature span which ensures vandal resistance in all locations.

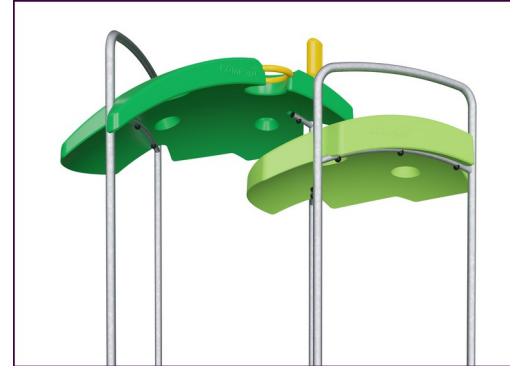

The ELEMENTS roofs are made of recyclable PE made from 33% post consumer recycled materials with a minimum wall thickness of 5 mm to ensure high durability in all climates around the world. The steel pipes are hot dip galvanised inside and outside for maximum durability.

Item no. PCE205221-0603	
Installation Information	
Max. fall height	204 cm
Safety surfacing area	75.8 m ²
Total installation time	36.0
Excavation volume	1.34 m ³
Concrete volume	0.74 m ³
Footing depth (standard)	60 cm
Shipment weight	1,194 kg
Anchoring options	Surface ✓ In-ground ✓
Warranty Information	
Curved panels	10 years
EcoCore HDPE	Lifetime
Membrane	2 years
Post	10 years
Spare parts guaranteed	10 years



The main posts are made of high quality pregalvanized steel with powder coated top finish. Post tops are closed with caps of UV stabilized nylon (PA6). The grey colored molded decks are made of 75% post-consumer waste PP material with a non-skid pattern and texture surface. All decks are supported by unique designed low-carbon aluminum profiles with multiple attachment options.

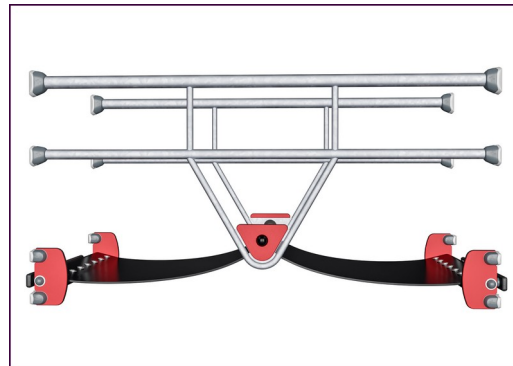

ELEMENTS rubber membranes are conveyer belt made of layers of rubber mixed of natural rubber and SBR rubber, and embedded with layers of armouring made of woven PE and PA. The thickness 8mm ensures high durability in any environment.

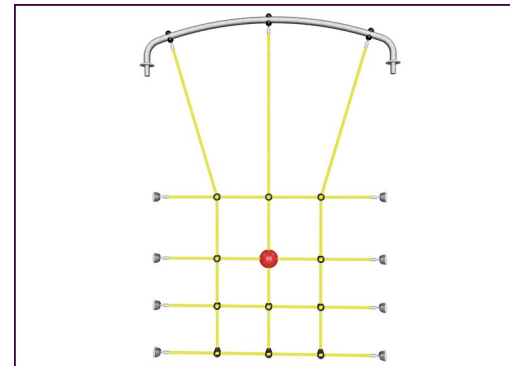

ELEMENTS ropes has six-stranded steel wires and a steel wire core. Each strand is tightly wrapped with PES yarn, which is made from +95% post consumer materials. The yarn is then melted onto each individual strand making the ropes highly wear- and vandalism-resistant.

Elevated activities 10	Accessible elevated activities	Accessible ground level activities	Accessible ground level play types
Present	10	3	2
Required	5	3	2

**CSA
Z614**
compliant

Sustainability Data

PCE205221



Cradle to Gate A1-A3	Total CO ₂ emission	CO ₂ e/kg	Recycled materials
	kg CO ₂ e	kg CO ₂ e/kg	%
PCE205221-0603	2,610.55	2.81	45.02

The overall framework applied for these factors is the Environmental Product Declaration (EPD), which quantifies "environmental information on the life cycle of a product and enable comparisons between products fulfilling the same function" (ISO, 2006). This follows the structure and applies a Life-Cycle Assessment approach to the entire Product stage from raw material through manufacturing (A1-A3))

Kompan A/S
 C.F. Tietgens Boulevard 32C
 DK-5220 Odense SØ
 Denmark



Verification of CO₂ calculation of: Play systems



Data version no. 2023-10-05

The CO₂ calculation and data are in compliance with the principles of a carbon footprint impact according to the GHG protocol (Greenhouse Gas Protocol), Scope 3, cradle to gate related to all individual components in the product category: "Play systems" represented by item no.: PCM200321-0950.

(Scope 3 emissions include emission sources in the upstream and downstream value chain).

Date: 30. October 2023 | Valid until: 30. October 2025

Verified by:

Julie Marie Vejsgaard Larsen, LCA & EPD Consultant

Verification based on report: Validation of CO₂ calculation of 9 categories of Kompan product line, version 1.0, prepared by: Bureau Veritas HSE, Denmark: Julie M. V. Larsen.

Publication date: 30. October 2023

By Bureau Veritas HSE
 www.bureauveritas.dk
 +45 7731 1000



Mountaineer

PCE205221

* Max fall height | ** Total height | *** Safety surfacing area

* Max fall height | ** Total height

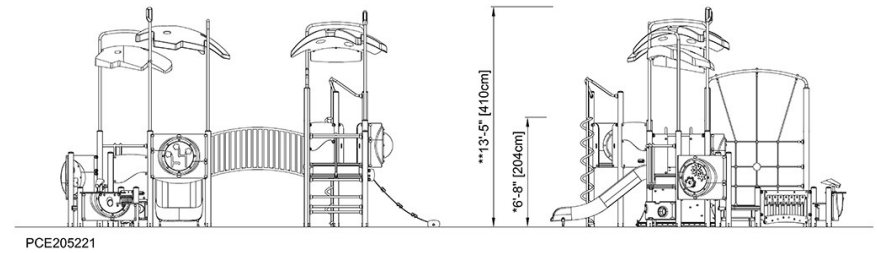
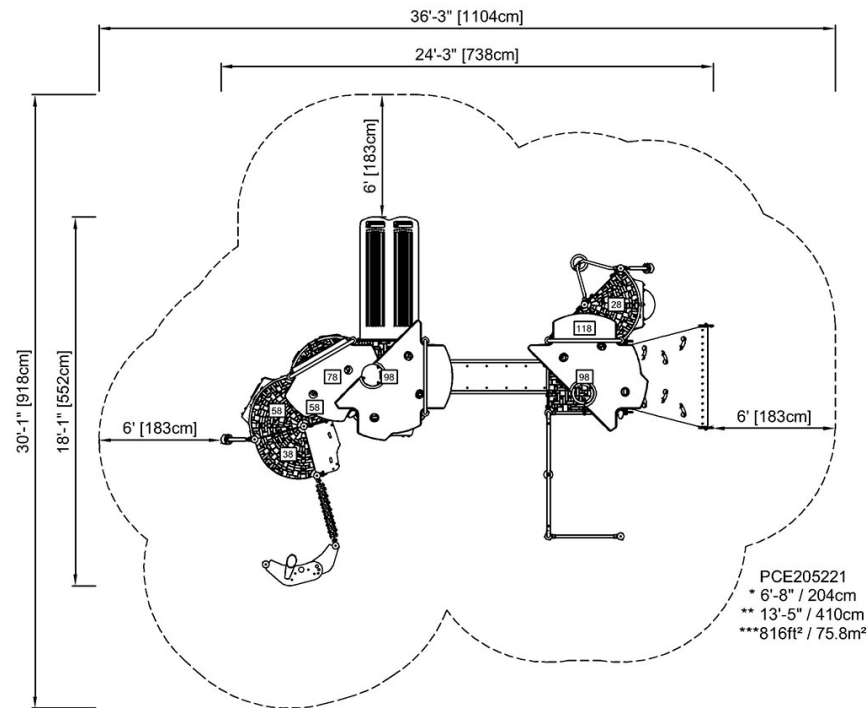

[Click to see TOP VIEW](#)

[Click to see SIDE VIEW](#)