

# Robinia Cliff Rider, H:238cm

NRO2015

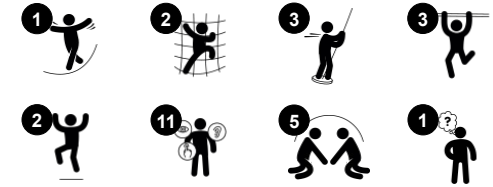

Item no. NRO2015-1021	
General Product Information	
Dimensions LxWxH	687x403x417 cm
Age group	6+
Play capacity (users)	20
Color options	



The amazing taller Cliff Rider is hugely attractive to school age children. It calls for repeated loops of action, again and again. The intensely thrilling ride high up in the air, on a small footrest, is for the courageous. And those who aren't at the first go, get there with a little help from their friends. Till then, there is ample climbing and gliding on the Pipe Ladder,

Climbing Net, Banister Bars and the Fireman's Pole. The Cliff Rider trains muscle force, tension, timing and sequencing of movements. It builds life skills that make it possible to navigate the body securely and confidently through for instance street traffic. Furthermore, the self-confidence that children gain from overcoming their initial hesitations to travel on

the Cliff Rider, builds social-emotional fundamentals for friendships.



# Robinia Cliff Rider, H:238cm

NRO2015



The pole vaulter pole is made of a welded steel construction with a 360° standing platform of Ekogrip. The double sided curved handles are made of EcoCore material. The pole combines superior ergonomics with outstanding functionality.



The rocking movement back and forth is controlled by a heavy duty scaled double rubber torsion spring element. The rubber element ensures a safe movement and reduces speed towards the tower platforms. The base cover of molded PE material with high impact resistance.



The Robinia products are designed with a KOMPAN colour concept with a number of different standard colours. The wood can also be supplied as untreated or with brown painted with a pigment that maintains the wood colour.

Item no. NRO2015-1021

### Installation Information

Max. fall height	300 cm
Safety surfacing area	65.1 m <sup>2</sup>
Total installation time	38.2
Excavation volume	1.98 m <sup>3</sup>
Concrete volume	1.13 m <sup>3</sup>
Footing depth (standard)	100 cm
Shipment weight	1,654 kg
Anchoring options	Surface ✓ In-ground ✓



The curved start platforms are made of a curved stainless steel plate with non skid texture. The lower part of the platform is supported by a EcoCore board for safe foothold and the rubber bumper is placed to receive the pole.

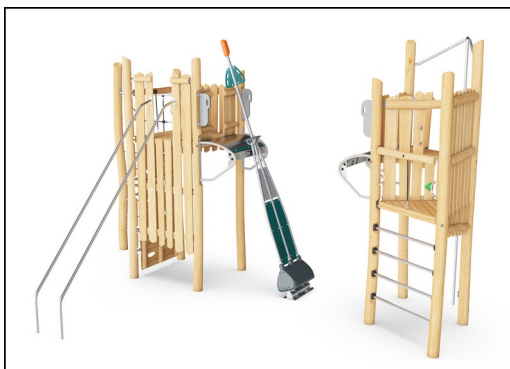

All Organic Robinia products by KOMPAN are made of Robinia wood from sustainable European sources. On request it can be supplied as FSC® Certified (FSC® C004450).



The paint used for coloured components is water based environmental friendly with excellent UV resistance. The paint is in compliance with EN 71 Part 3.



# Sustainability Data

NRO2015



Cradle to Gate A1-A3	Total CO <sub>2</sub> emission	CO <sub>2</sub> e/kg	Recycled materials
	kg CO <sub>2</sub> e	kg CO <sub>2</sub> e/kg	%
<b>NRO2015-1021</b>	1,069.50	0.81	11.50

The overall framework applied for these factors is the Environmental Product Declaration (EPD), which quantifies "environmental information on the life cycle of a product and enable comparisons between products fulfilling the same function" (ISO, 2006). This follows the structure and applies a Life-Cycle Assessment approach to the entire Product stage from raw material through manufacturing (A1-A3))

**Kompan A/S**  
 C.F. Tietgens Boulevard 32C  
 DK-5220 Odense SØ  
 Denmark



## Verification of CO<sub>2</sub> calculation of: Nature play



Data version no. 2023-10-05

The CO<sub>2</sub> calculation and data are in compliance with the principles of a carbon footprint impact according to the GHG protocol (Greenhouse Gas Protocol), Scope 3, cradle to gate related to all individual components in the product category: "Nature play" represented by item no.: NRO409-0621.

(Scope 3 emissions include emission sources in the upstream and downstream value chain).

**Date: 30. October 2023 | Valid until: 30. October 2025**

**Verified by:**

Julie Marie Vejsgaard Larsen, LCA & EPD Consultant

Verification based on report: Validation of CO<sub>2</sub> calculation of 9 categories of Kompan product line, version 1.0, prepared by: Bureau Veritas HSE, Denmark: Julie M. V. Larsen.

**Publication date: 30. October 2023**

**By Bureau Veritas HSE**  
 www.bureauveritas.dk  
 +45 7731 1000



# Robinia Cliff Rider, H:238cm

NRO2015

\* Max fall height | \*\* Total height | \*\*\* Safety surfacing area

\* Max fall height | \*\* Total height

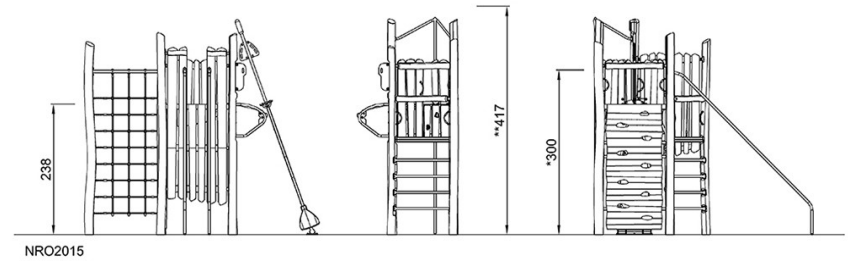
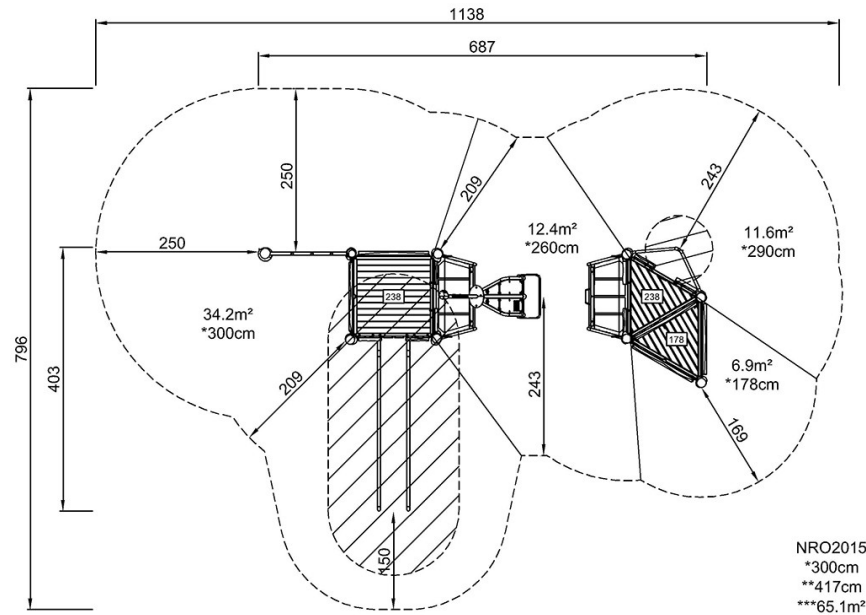

[Click to see TOP VIEW](#)

[Click to see SIDE VIEW](#)