

Dress-Up Cottage

NRO605

KOMPANI
Let's play



Item no. NRO605-0621	
General Product Information	
Dimensions LxWxH	181x190x256 cm
Age group	1+
Play capacity (users)	8
Color options	

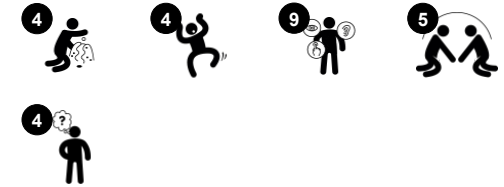

The Robinia Dress-Up Cottage is an immense play invitation for toddlers and preschoolers. With its varied play props for exploration and dramatic play and its openness in design it makes for hours of active socialising for toddlers, again and again. The many tactile and dramatic play details: clock, bell, mirror and flaps with shelf invite dramatic play, which

develops language skills. These items also stimulate logical thinking, the understanding of object permanence and identity. The transparency and openings invite social interaction from inside to outside of the house as well as dramatic play. It also encourages moving and climbing over and through, stimulating gross motor skills as well as sense

of space.



Data is subject to change without prior notice.

Dress-Up Cottage

NRO605



All Organic Robinia products by KOMPAN are made of Robinia wood from sustainable European sources. On request it can be supplied as FSC® Certified (FSC® C004450).



The paint used for coloured components is water based environmental friendly with excellent UV resistance. The paint is in compliance with EN 71 Part 3.



Play activities in very strong materials: HDPE-plate with HDPE-clock and hands in conveyer belt rubber, bell in pressed aluminium. Mirror in plexi-glass with a high impact resistant.

Item no. NRO605-0621

Installation Information

Max. fall height	0 cm
Safety surfacing area	17.4 m ²
Total installation time	12.3
Excavation volume	0.30 m ³
Concrete volume	0.00 m ³
Footing depth (standard)	60 cm
Shipment weight	617 kg
Anchoring options	In-ground ✓ Surface ✓



All rubber activities/components are made of conveyer belt rubber that makes it extremely weather resistant and long lasting.

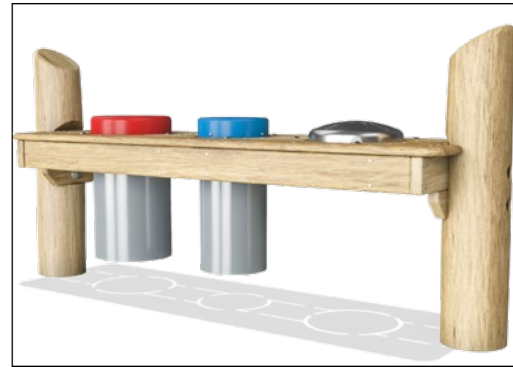

The percussion panel consist of 2 Conga Drums with PP tubes and top in coloured ABS. Babel drum in stainless steel 316L.

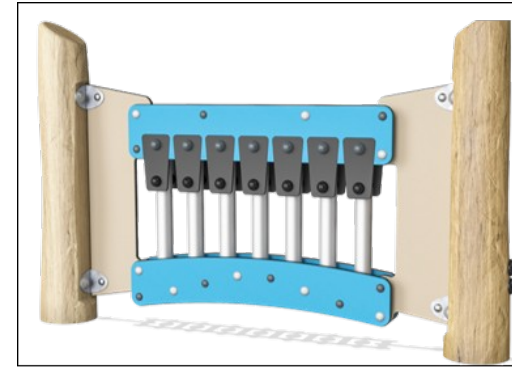

The Xylofon music panel consist of HDPE - material in 19mm EcoCore™. EcoCore™ is a highly durable, ecofriendly material. The pipes are made of die-cast aluminium specifically alloyed for outdoor environments.



Sustainability Data

NRO605



Cradle to Gate A1-A3	Total CO ₂ emission	CO ₂ e/kg	Recycled materials
	kg CO ₂ e	kg CO ₂ e/kg	%
NRO605-0621	111.40	0.23	2.30

The overall framework applied for these factors is the Environmental Product Declaration (EPD), which quantifies "environmental information on the life cycle of a product and enable comparisons between products fulfilling the same function" (ISO, 2006). This follows the structure and applies a Life-Cycle Assessment approach to the entire Product stage from raw material through manufacturing (A1-A3))

Kompan A/S
 C.F. Tietgens Boulevard 32C
 DK-5220 Odense SØ
 Denmark



Verification of CO₂ calculation of: Nature play



Data version no. 2023-10-05

The CO₂ calculation and data are in compliance with the principles of a carbon footprint impact according to the GHG protocol (Greenhouse Gas Protocol), Scope 3, cradle to gate related to all individual components in the product category: "Nature play" represented by item no.: NRO409-0621.

(Scope 3 emissions include emission sources in the upstream and downstream value chain).

Date: 30. October 2023 | Valid until: 30. October 2025

Verified by:

Julie Marie Vejsgaard Larsen, LCA & EPD Consultant

Verification based on report: Validation of CO₂ calculation of 9 categories of Kompan product line, version 1.0, prepared by: Bureau Veritas HSE, Denmark: Julie M. V. Larsen.

Publication date: 30. October 2023

By Bureau Veritas HSE
 www.bureauveritas.dk
 +45 7731 1000



Dress-Up Cottage

NRO605

* Max fall height | ** Total height | *** Safety surfacing area

* Max fall height | ** Total height

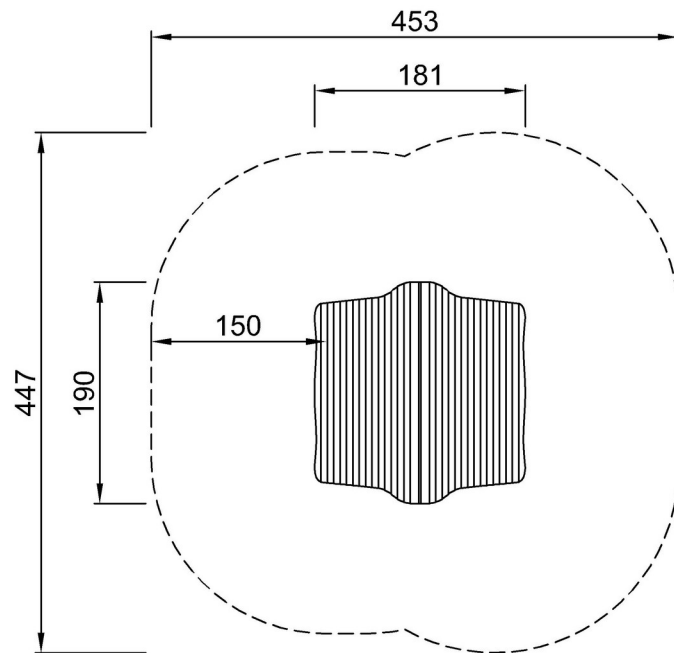

NRO605
**256cm
***17.4m²

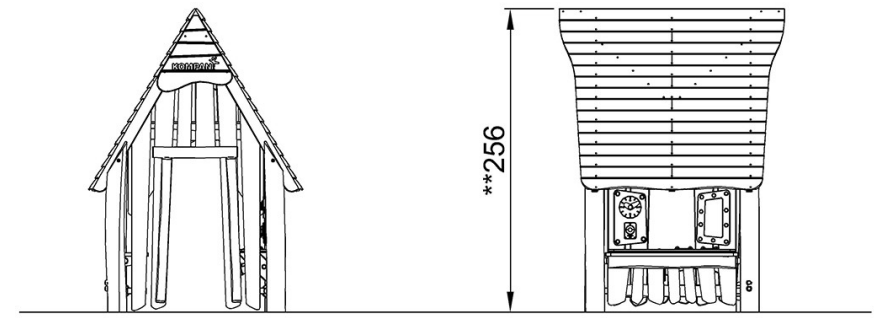

NRO605

[Click to see TOP VIEW](#)

[Click to see SIDE VIEW](#)