

# Uno Climber

PCM81021



The Uno Climber is a playground favorite with school children. They are immediately attracted to the dense, versatile activity hub. Thanks to the varied climbing opportunities with hanging bars, rope ladders and stable climbing wall with cleats and climb-through-hole, all children have a chance of doing something. The openness in design also invites conversation and social

interaction across the Uno Climber. This supports children's socio-emotional development and invites all in. With its combination of activities, the Uno Climber stimulates children's cross-coordination, strenght and bone density. All of these abilities are built for life in childhood. So the more they play, the more they gain.

Item no. PCM81021-0950

## General Product Information

Dimensions LxWxH	121x289x240 cm
Age group	6+
Play capacity (users)	5
Colour options	

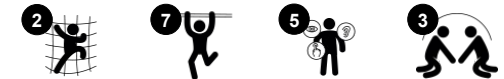

# Uno Climber

PCM81021



## Pipe climber

**Physical:** muscle strength, cross coordination, and spatial awareness when climbing. **Social-Emotional:** encourage socializing when seated on the bars.



## Climbing wall

**Physical:** develops children's cross coordination, eye-hand coordination, and muscle strength when climbing. **Social-Emotional:** two-sided climb invites cooperation.



## Overhead ladder

**Physical:** develops children's upper body muscles and arm strength, cross coordination and spatial awareness. This is especially important due to sedentary lifestyles and back-pain in children. **Social-Emotional:** chill and socialize on top of the overhead ladder, training cooperation.

# Uno Climber

PCM81021



Main posts with hot dip galvanized steel footing are available in different materials: Pressure impregnated pine wood posts. Pre-galvanized inside and outside with powder coated top finish steel posts. Lead free aluminum with color anodized top finish. Greenline TexMade posts of 95% post-consumer recycled PE and textile waste.



Panels of 19mm EcoCore™. EcoCore™ is a highly durable, eco friendly material, which is not only recyclable after use, but also consists of material produced from +95% recycled post consumer material from food packing waste.



The steel surfaces are hot dip galvanized inside and outside with lead free zinc. The galvanisation has excellent corrosion resistance in outside environments and requires low maintenance.



Ropes of UV-stabilized PES rope strands with inner steel cable reinforcement. The polyester yarn is made from +95% post-consumer materials and is inductively melted onto each strand.



KOMPAN GreenLine versions are designed with ultimate environmentally friendly materials with lowest possible CO2e emission factor. TexMade post, EcoCore™ panels of 95% post-consumer recycled waste and molded PP decks.

Item no. PCM81021-0950

### Installation Information

Max. fall height	223 cm
Safety surfacing area	28.0 m <sup>2</sup>
Total installation time	5.5
Excavation volume	0.91 m <sup>3</sup>
Concrete volume	0.38 m <sup>3</sup>
Footing depth (standard)	90 cm
Shipment weight	251 kg
Anchoring options	Surface ✓ In-ground ✓

### Warranty Information

EcoCore HDPE	Lifetime
Hot dip galvanized steel	Lifetime
Post	10 years
Ropes & nets	10 years
Spare parts guaranteed	10 years



# Sustainability Data

PCM81021



Cradle to Gate A1-A3	Total CO <sub>2</sub> emission	CO <sub>2</sub> e/kg	Recycled materials
	kg CO <sub>2</sub> e	kg CO <sub>2</sub> e/kg	%
<b>PCM81021-0950</b>	297.91	1.76	72.99
<b>PCM81021-0901</b>	359.72	2.73	56.67

The overall framework applied for these factors is the Environmental Product Declaration (EPD), which quantifies "environmental information on the life cycle of a product and enable comparisons between products fulfilling the same function" (ISO, 2006). This follows the structure and applies a Life-Cycle Assessment approach to the entire Product stage from raw material through manufacturing (A1-A3))

**Kompan A/S**  
C.F. Tietgens Boulevard 32C  
DK-5220 Odense SØ  
Denmark



## Verification of CO<sub>2</sub> calculation of: Freestanding play equipment



Data version no. 2023-10-05

The CO<sub>2</sub> calculation and data are in compliance with the principles of a carbon footprint impact according to the GHG protocol (Greenhouse Gas Protocol), Scope 3, cradle to gate related to all individual components in the product category: "Freestanding play equipment" represented by item no.: GXY916012-3417.

(Scope 3 emissions include emission sources in the upstream and downstream value chain).

**Date: 30. October 2023 | Valid until: 30. October 2025**

Verified by:

Julie Marie Vejsgaard Larsen, LCA & EPD Consultant

Verification based on report: Validation of CO<sub>2</sub> calculation of 9 categories of Kompan product line, version 1.0, prepared by: Bureau Veritas HSE, Denmark: Julie M. V. Larsen.

**Publication date: 30. October 2023**

By Bureau Veritas HSE  
www.bureauveritas.dk  
+45 7731 1000



# Uno Climber

PCM81021

\* Max fall height | \*\* Total height | \*\*\* Safety surfacing area

\* Max fall height | \*\* Total height

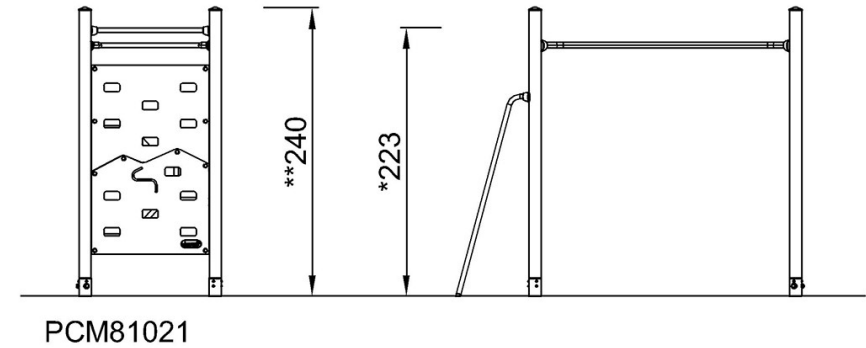
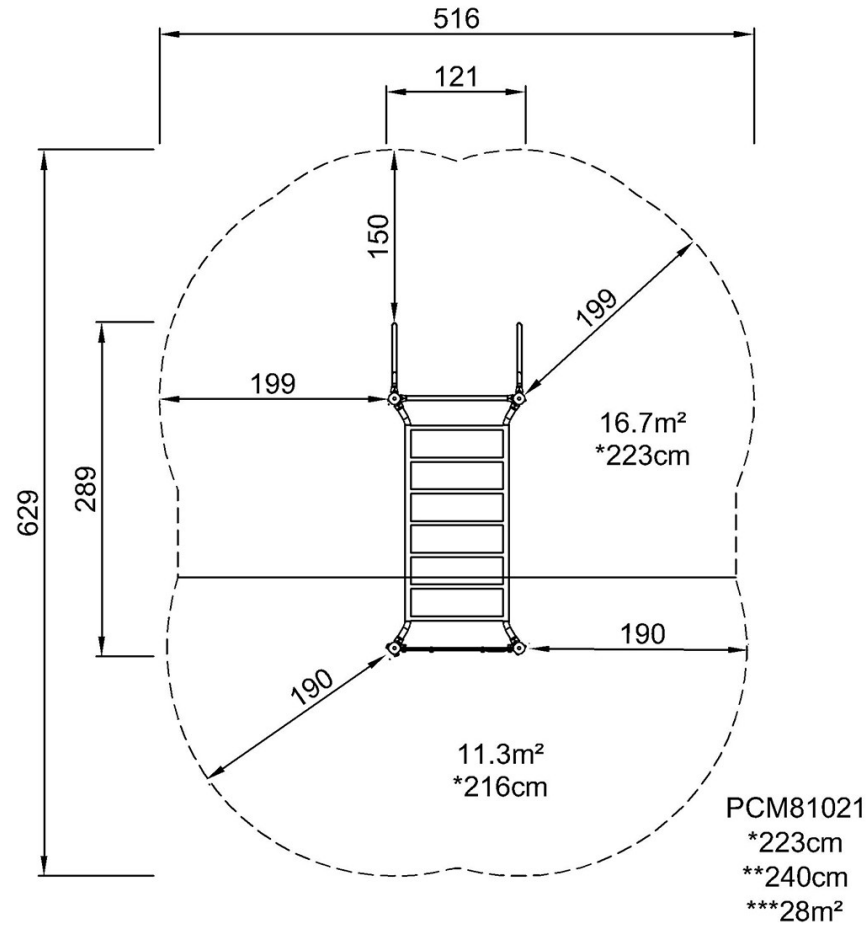

[Click to see TOP VIEW](#)

[Click to see SIDE VIEW](#)