

Castle Gatehouse

PCM201721



The Castle Gatehouse will attract young children to play actively, using their motor skills to climb to the top, navigate the nets, and slide or glide to the ground. The two access points vary in difficulty: the stairs provides an age-appropriate access to the tower and helps to develop skills at climbing stairs, an important everyday task. The inclined net climb is higher

and takes more concentration, stimulating proprioception and cross-coordination. These are fundamental for navigating the world securely. The open, inclined bridge is a true challenge, training balance skills and the sense of space. A slide or fireman's pole lead back to ground level. Sliding trains the sense of balance and the posture, both great for body

confidence. The fine dramatic play area with treasure chest and bench under the tower invites social interaction and stimulates language development.



Item no. PCM201721-0901

General Product Information

Dimensions LxWxH	350x335x410 cm
Age group	2+
Play capacity (users)	16
Colour options	●

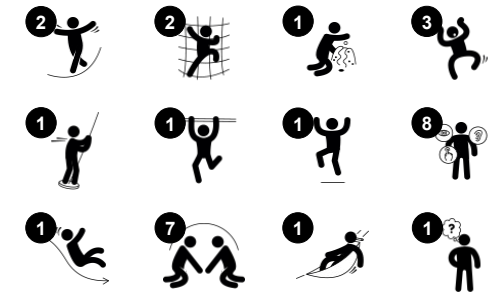

Castle Gatehouse

PCM201721



Cannon

Cognitive: the cannon set a tangible theme and thus spur dramatic play. Dramatic play supports language and communication skills.



Fireman's pole

Physical: coordination is supported when going down, as well as arm and core muscles. Landing strengthens bone density, which is built for life in early childhood. **Social-Emotional:** turn-taking and risk-taking.



Climbing net

Physical: supports physical strength and cross-body coordination, which impacts coordination of the right and left part of brain, fundamental for other skills such as the ability to read.



Treasure box

Cognitive: object permanence: hiding objects and finding them again. Spurs exploration and dramatic play, stimulating conversations.



Net bridge, inclined

Physical: walking the open net up or downwards develops balance, spatial awareness and cross coordination. **Social-Emotional:** interaction with children outside, socializing. Cooperation and consideration, e.g. when passing others.

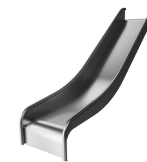

Slide

Physical: sliding develops spatial awareness and a sense of balance. Furthermore, the core muscles are trained when sitting upright going down. **Social-Emotional:** empathy stimulated by turn-taking.

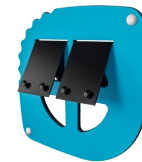

Window with curtains

Physical: tactile stimulation supports sensory skills, when children explore characteristics of the materials. **Social-Emotional:** social interaction between inside and outside, supporting turn-taking and cooperation. **Cognitive:** understanding object permanence when playing, e.g. peek-a-boo. Dramatic play support, encouraging language skills. **Creative:** leaving a mark, deciding how to place curtains.

Castle Gatehouse

PCM201721



Panels of 19mm EcoCore™. EcoCore™ is a highly durable, eco friendly material, which is not only recyclable after use, but also consists of material produced from +95% recycled post consumer material from food packing waste.



Main posts with hot dip galvanised steel footing are available in different materials: Pressure impregnated pine wood posts. Pre-galvanised inside and outside with powder coated top finish steel posts. Lead free aluminium with colour anodised top finish.



All decks are supported by unique designed low-carbon aluminum profiles with multiple attachment options. The grey colored molded decks are made of 75% post-consumer waste PP material with a non-skid pattern and texture surface.

Item no. PCM201721-0901	
Installation Information	
Max. fall height	118 cm
Safety surfacing area	30.9 m ²
Total installation time	18.0
Excavation volume	1.12 m ³
Concrete volume	0.38 m ³
Footing depth (standard)	90 cm
Shipment weight	527 kg
Anchoring options	In-ground ✓ Surface ✓
Warranty Information	
EcoCore HDPE	Lifetime
Post	10 years
PP Decks	10 years
Ropes & nets	10 years
Spare parts guaranteed	10 years



The slides can be chosen in different materials and colours: Straight or curved moulded PE slides in yellow or grey colour. Full stainless steel in on-piece design for more vandalism proof solutions.

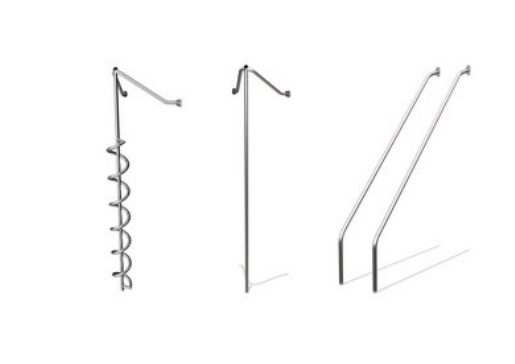

The stainless-steel activities are made of high-quality stainless steel. The steel is cleaned by a total pickling process after manufacturing to ensure a smooth and clean gliding surfaces.



Nets and ropes are made of UV-stabilised PA with inner steel cable reinforcement. The rope is induction treated in order to create a strong connection between steel and rope which leads to good wear resistance.



Sustainability Data

PCM201721



Cradle to Gate A1-A3	Total CO ₂ emission	CO ₂ e/kg	Recycled materials
	kg CO ₂ e	kg CO ₂ e/kg	%
PCM201721-0901	1,012.12	2.72	54.15

The overall framework applied for these factors is the Environmental Product Declaration (EPD), which quantifies "environmental information on the life cycle of a product and enable comparisons between products fulfilling the same function" (ISO, 2006). This follows the structure and applies a Life-Cycle Assessment approach to the entire Product stage from raw material through manufacturing (A1-A3))

Kompan A/S
 C.F. Tietgens Boulevard 32C
 DK-5220 Odense SØ
 Denmark



Verification of CO₂ calculation of: Themed play systems



Data version no. 2023-10-05

The CO₂ calculation and data are in compliance with the principles of a carbon footprint impact according to the GHG protocol (Greenhouse Gas Protocol), Scope 3, cradle to gate related to all individual components in the product category: "Themed play systems" represented by item no.: MSC641100-3717P.

(Scope 3 emissions include emission sources in the upstream and downstream value chain).

Date: 30. October 2023 | Valid until: 30. October 2025

Verified by:

Julie Marie Vejsgaard Larsen, LCA & EPD Consultant

Verification based on report: Validation of CO₂ calculation of 9 categories of Kompan product line, version 1.0, prepared by: Bureau Veritas HSE, Denmark: Julie M. V. Larsen.

Publication date: 30. October 2023

By Bureau Veritas HSE
 www.bureauveritas.dk
 +45 7731 1000



Castle Gatehouse

PCM201721

* Max fall height | ** Total height | *** Safety surfacing area

* Max fall height | ** Total height

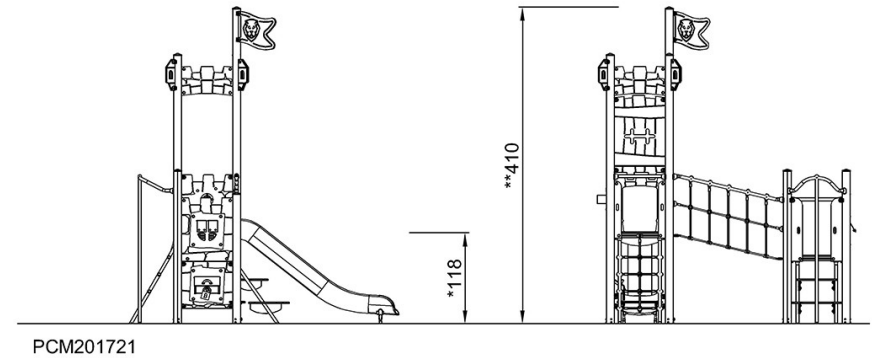
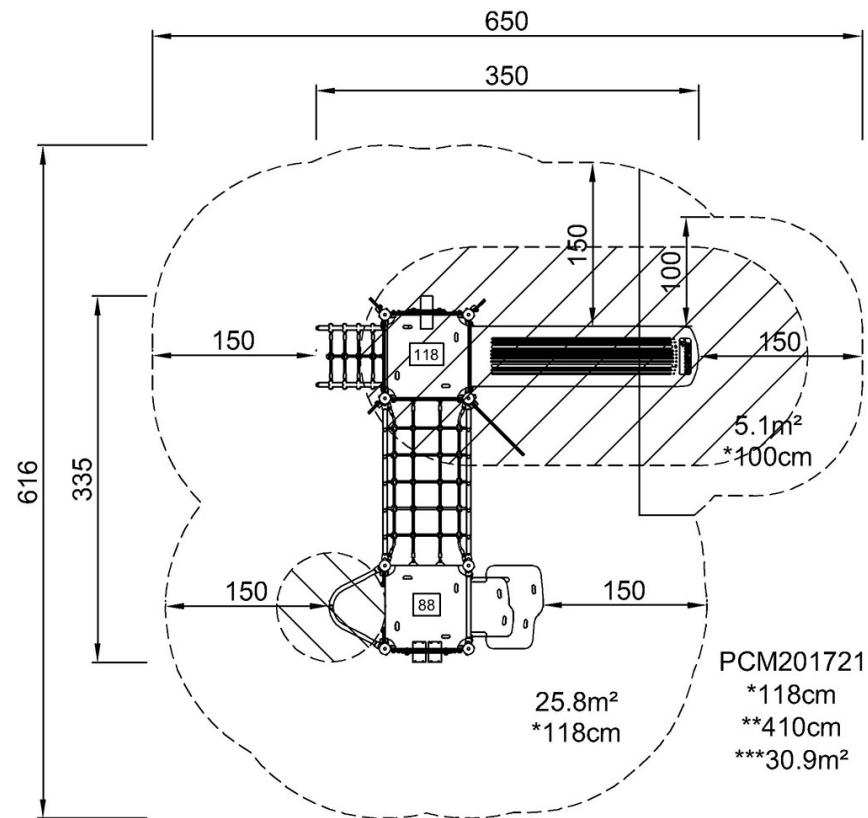

[Click to see TOP VIEW](#)

[Click to see SIDE VIEW](#)