

Dune Buggy

M170



Item no. M17003-01P	
General Product Information	
Dimensions LxWxH	40x88x77 cm
Age group	1+
Play capacity (users)	1
Colour options	



Rocking on the Dune Buggy is a fun playground activity that children will return to again and again. Children are able to control the play by moving their bodies to make the Dune Buggy rock. They will feel delighted to have the buggy respond to their movements. The two sides support the seated position, and the foot and hand holds provide a stable point

to stem feet and hands from, to create the movement. This is not only fun but is also good for physical and cognitive development. When children begin to learn the connections between their bodies and their movements, they begin to make cognitive connections to a range of body movements and sensations. The dune buggy theme will open up the child's

imagination and will encourage physical and imaginative play.



Dune Buggy

M170



Theme

Cognitive: suggests a theme and supports dramatic play, which stimulates language and communication skills.



Rocking spring

Physical: response to movements adds to spatial awareness and sense of balance which are fundamental motor skills.

Cognitive: trains the understanding of cause and effect: when I move my body, the spring responds with movement.



Handhold

Physical: opens more hold positions and ensures good grip, necessary for rocking intensely which trains hand and arm muscles.



Foot support

Physical: the footrest supports intensive rocking, which stimulates the senses of balance and space, fundamental for managing the world securely.

Dune Buggy

M170



Panels of 19mm EcoCore™. EcoCore™ is a highly durable, eco-friendly material, which is not only recyclable after use but also consists of a core produced from 100% recycled material.

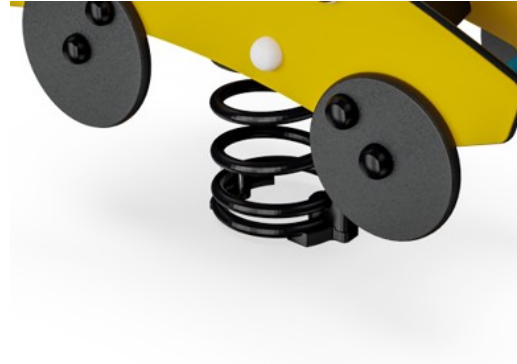

KOMPAN's springs are manufactured from high-quality spring steel. The springs are cleaned by phosphating before being painted with epoxy primer and polyester powder coating. The springs are fixed by unique anti-pinch fittings for maximum safety and longevity.

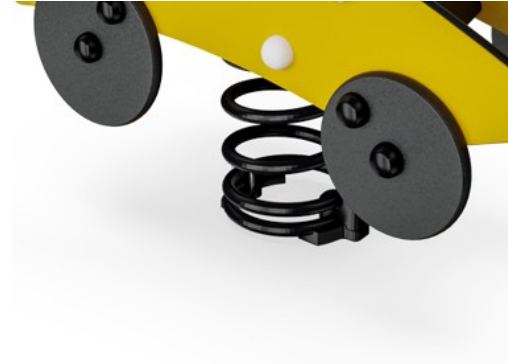

The springs are fixed by unique anti-pinch fittings for maximum safety and longevity.

Item no. M17003-01P	
Installation Information	
Max. fall height	60 cm
Safety surfacing area	7.5 m ²
Total installation time	2.8
Excavation volume	0.19 m ³
Concrete volume	0.00 m ³
Footing depth (standard)	45 cm
Shipment weight	42 kg
Anchoring options	In-ground ✓ Surface ✓
Warranty Information	
EcoCore HDPE	Lifetime
Galvanised Steel	Lifetime
Spare Parts Guarantee	10 years
Springs	5 years



The handle is made of polypropylene PP, which has excellent impact strength and is suitable for hot climates.



The steel support posts are hot-dip galvanised inside and outside with lead free zinc. The galvanisation has excellent corrosion resistance in outside environments and requires low maintenance.

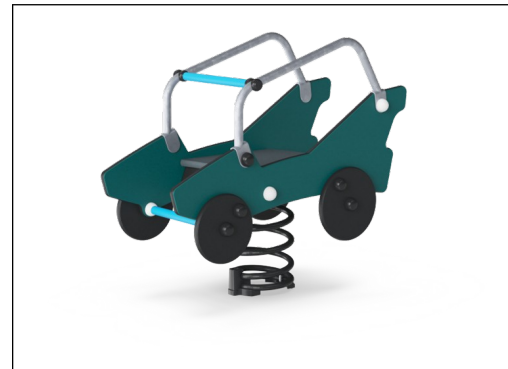

KOMPAN GreenLine versions are designed with ultimate environmentally friendly materials with the lowest possible CO2e emission factor such as EcoCore™ panels of 100% post consumer recycled ocean waste.



Sustainability Data

M170



Cradle to Gate A1-A3	Total CO ₂ emission	CO ₂ e/kg	Recycled materials
	kg CO ₂ e	kg CO ₂ e/kg	%
M17003-01P	81.76	2.33	52.54

The overall framework applied for these factors is the Environmental Product Declaration (EPD), which quantifies "environmental information on the life cycle of a product and enable comparisons between products fulfilling the same function" (ISO, 2006). This follows the structure and applies a Life-Cycle Assessment approach to the entire Product stage from raw material through manufacturing (A1-A3))

Kompan A/S
 C.F. Tietgens Boulevard 32C
 DK-5220 Odense SØ
 Denmark



Verification of CO₂ calculation of: Freestanding play equipment



Data version no. 2023-10-05

The CO₂ calculation and data are in compliance with the principles of a carbon footprint impact according to the GHG protocol (Greenhouse Gas Protocol), Scope 3, cradle to gate related to all individual components in the product category: "Freestanding play equipment" represented by item no.: GXY916012-3417.

(Scope 3 emissions include emission sources in the upstream and downstream value chain).

Date: 30. October 2023 | Valid until: 30. October 2025

Verified by:

Julie Marie Vejsgaard Larsen, LCA & EPD Consultant

Verification based on report: Validation of CO₂ calculation of 9 categories of Kompan product line, version 1.0, prepared by: Bureau Veritas HSE, Denmark: Julie M. V. Larsen.

Publication date: 30. October 2023

By Bureau Veritas HSE
 www.bureauveritas.dk
 +45 7731 1000



Dune Buggy

M170

* Max fall height | ** Total height | *** Safety surfacing area

* Max fall height | ** Total height

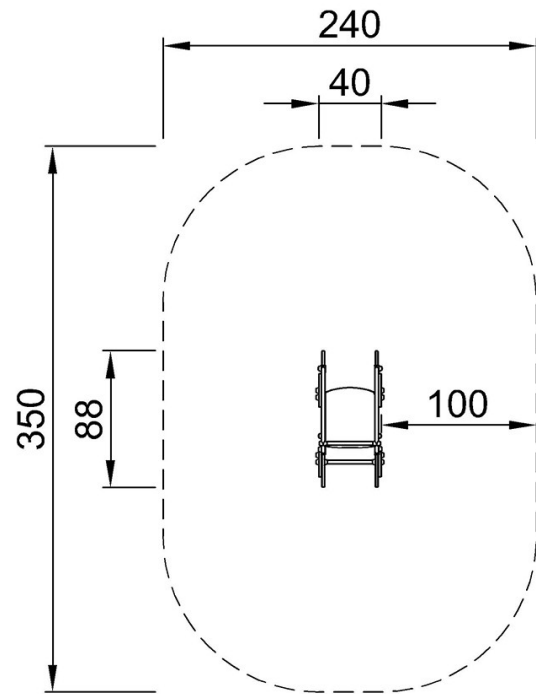

M17003
*60cm
**77cm
***7.5m²

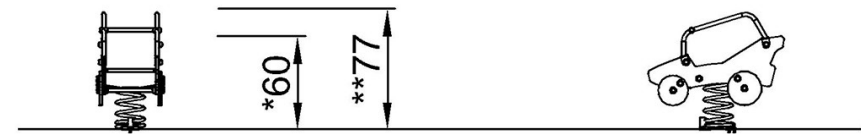

M17003

[Click to see TOP VIEW](#)

[Click to see SIDE VIEW](#)