

Castle Fortress

PCM113021

KOMPAN
Let's play

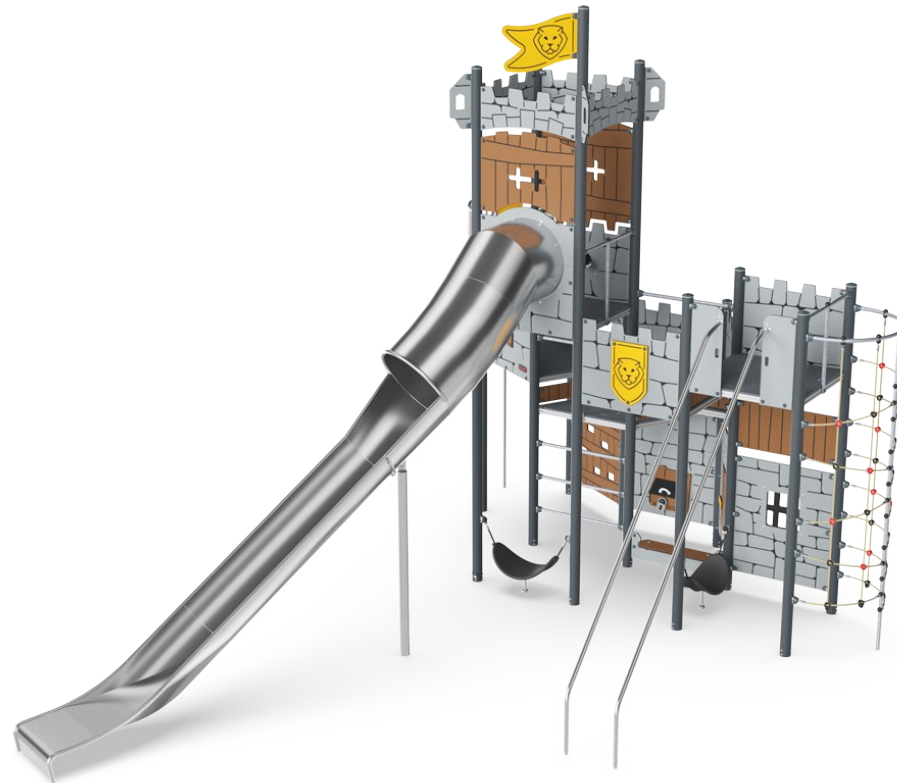

Item no. PCM113021-0901	
General Product Information	
Dimensions LxWxH	783x530x561 cm
Age group	4+
Play capacity (users)	30
Color options	●

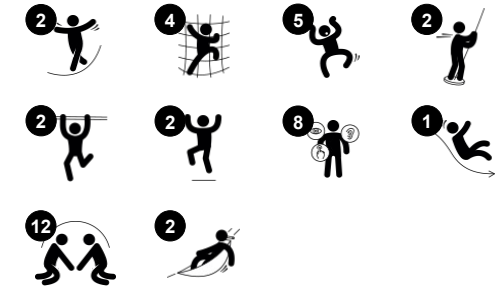

The Castle Fortress provides for play challenges and lots of varied movement. This fortress will inspire young children to challenge themselves to play actively and imaginatively, using their muscles to climb to the top and slide down to the ground. The climbing net provides a variation in climbing, developing children's cross-coordination, which in turn supports

intellectual development. The wild slide is a thrilling ride, training children's balance skills. The bannister bars are great for dare-devils, building up proprioception and sense of balance. These are fundamental in children's ability to navigate the world securely. The cellars of the Castle Fortress inspire creative and dramatic play. Special surprises such as

the treasure chest and prison window will be a constant attraction, stimulating social play and language development. Swaying hammocks add a possibility for a break with friends.

Castle Fortress

PCM113021



Theme

Cognitive: suggests a theme and supports dramatic play, which stimulates language and communication skills.

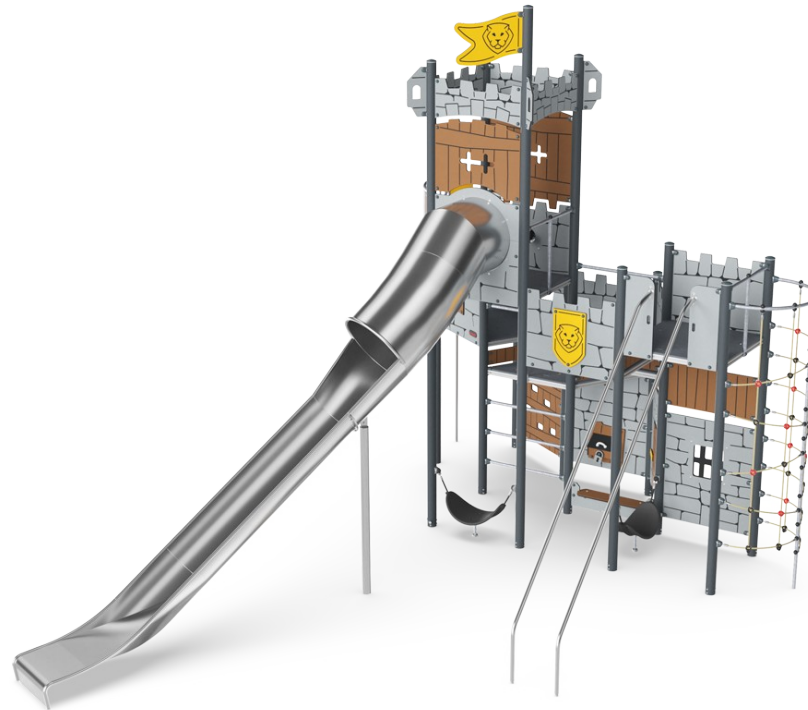

Tower net

Physical: the children have fast access up the horizontal rungs, and a slower climb up the sloping rungs. The net can be climbed from both sides, levelling the challenge. Cross coordination, and arm and leg muscles are trained. **Social-Emotional:** the two-sided net and spaciousness allows for social interaction. **Cognitive:** logical thinking when planning how to best enter the platform from the net.



Hammock

Physical: coordination and sense of balance when swaying. **Social-Emotional:** meeting, pushing friends gently back and forth, turn-taking. **Cognitive:** for toddlers cause and effect understanding.



Banister bars

Physical: coordination is supported when going down, as well as arm and core muscles. Landing strengthens bone density, which is built for life in childhood. **Social-Emotional:** turn-taking and risk-taking.



Treasure box

Cognitive: object permanence: hiding objects and finding them again. Spurs exploration and dramatic play, stimulating conversations.

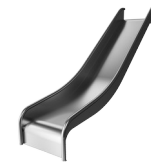

Slide

Physical: sliding develops spatial awareness and a sense of balance. Furthermore, the core muscles are trained when sitting upright going down. **Social-Emotional:** empathy stimulated by turn-taking.



Fireman's pole

Physical: coordination is supported when going down, as well as arm and core muscles. Landing strengthens bone density, which is built for life in early childhood. **Social-Emotional:** turn-taking and risk-taking.

Castle Fortress

PCM113021



Panels of 19mm EcoCore™. EcoCore™ is a highly durable, eco friendly material, which is not only recyclable after use, but also consists of material produced from +95% recycled post consumer material from food packing waste.



Main posts with hot dip galvanised steel footing are available in different materials: Pressure impregnated pine wood posts. Pre-galvanised inside and outside with powder coated top finish steel posts. Lead free aluminium with colour anodised top finish.



All decks are supported by unique designed low-carbon aluminum profiles with multiple attachment options. The grey colored molded decks are made of 75% post-consumer waste PP material with a non-skid pattern and texture surface.

Item no. PCM113021-0901

Installation Information

Max. fall height	300 cm
Safety surfacing area	70.1 m ²
Total installation time	36.2
Excavation volume	1.43 m ³
Concrete volume	0.47 m ³
Footing depth (standard)	90 cm
Shipment weight	1,591 kg
Anchoring options	In-ground ✓ Surface ✓



The slides can be chosen in different materials and colours: Straight or curved moulded PE slides in yellow or grey colour. Full stainless steel in on-piece design for more vandalism proof solutions.



The stainless-steel activities are made of high-quality stainless steel. The steel is cleaned by a total pickling process after manufacturing to ensure a smooth and clean gliding surfaces.



Nets and ropes are made of UV-stabilised PA with inner steel cable reinforcement. The rope is induction treated in order to create a strong connection between steel and rope which leads to good wear resistance.



Sustainability Data

PCM113021

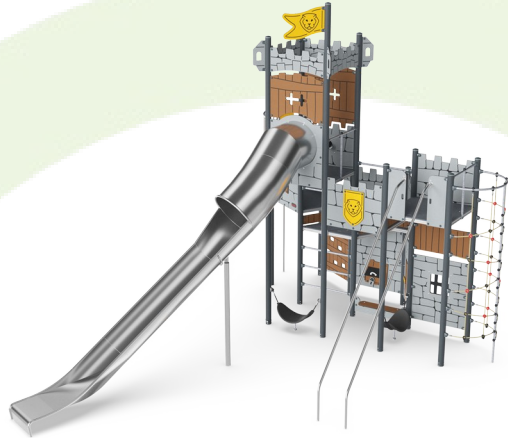

Cradle to Gate A1-A3	Total CO ₂ emission	CO ₂ e/kg	Recycled materials
	kg CO ₂ e	kg CO ₂ e/kg	%
PCM113021-0901	3,587.04	2.92	59.46

The overall framework applied for these factors is the Environmental Product Declaration (EPD), which quantifies "environmental information on the life cycle of a product and enable comparisons between products fulfilling the same function" (ISO, 2006). This follows the structure and applies a Life-Cycle Assessment approach to the entire Product stage from raw material through manufacturing (A1-A3))

Kompan A/S
 C.F. Tietgens Boulevard 32C
 DK-5220 Odense SØ
 Denmark



Verification of CO₂ calculation of: Themed play systems



Data version no. 2023-10-05

The CO₂ calculation and data are in compliance with the principles of a carbon footprint impact according to the GHG protocol (Greenhouse Gas Protocol), Scope 3, cradle to gate related to all individual components in the product category: "Themed play systems" represented by item no.: MSC641100-3717P.

(Scope 3 emissions include emission sources in the upstream and downstream value chain).

Date: 30. October 2023 | Valid until: 30. October 2025

Verified by:

Julie Marie Vejsgaard Larsen, LCA & EPD Consultant

Verification based on report: Validation of CO₂ calculation of 9 categories of Kompan product line, version 1.0, prepared by: Bureau Veritas HSE, Denmark: Julie M. V. Larsen.

Publication date: 30. October 2023

By Bureau Veritas HSE
 www.bureauveritas.dk
 +45 7731 1000



Castle Fortress

PCM113021

* Max fall height | ** Total height | *** Safety surfacing area

* Max fall height | ** Total height

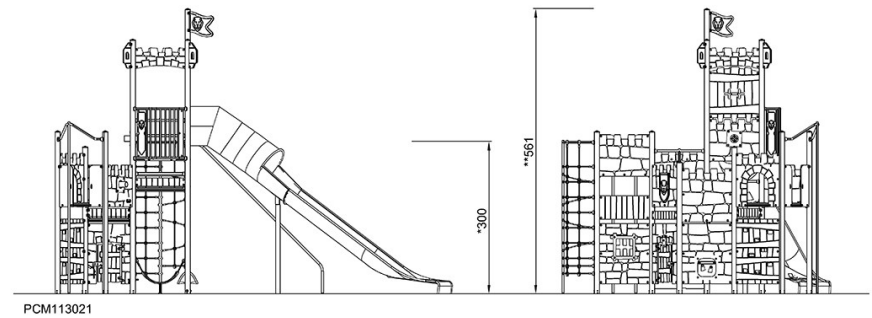
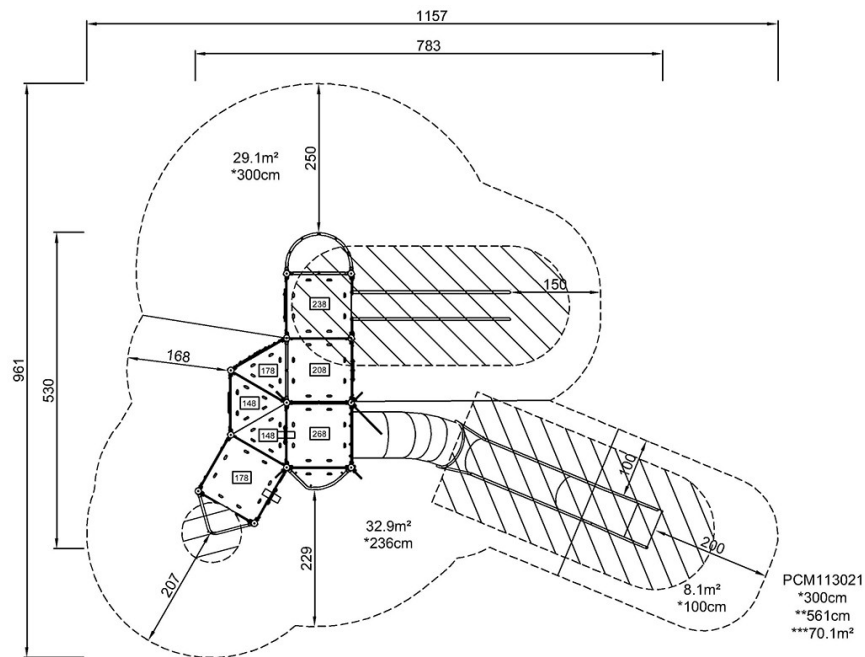

[Click to see TOP VIEW](#)

[Click to see SIDE VIEW](#)