

Anita Square Bench

PAR1055



Item no. PAR1055-0611

General Product Information

Dimensions LxWxH	181x181x44 cm
Age group	
Play capacity (users)	
Colour options	



Outdoor Furniture plays an essential role in our communities by adding an inviting and social atmosphere, a place to meet, socialise or rest. Anita is classic and comfortable park furniture that invites citizens to take a seat and relax. They blend into and enhance public areas like parks and playgrounds etc. Anita Square Bench can be placed around a tree, a light pole

or just as freestanding with multiple use from all sides. The bench is available with a backrest for increased seating comfort.

Anita Square Bench

PAR1055



Boards are made of pine wood from sustainable European sources. The wood is pressure-impregnated according to EN335:2013, Class 3 (Equivalent to NTR Class AB). On request it can be supplied as FSC® Certified (FSC® C004450).



The steel surfaces are hot dip galvanized inside and outside with lead free zinc. The galvanization has excellent corrosion resistance in outdoor environments and require low maintenance.



The benches and tables can be combined in multiple settings by choosing individual products or assembled into larger solutions. See catalogue pages for more inspiration.

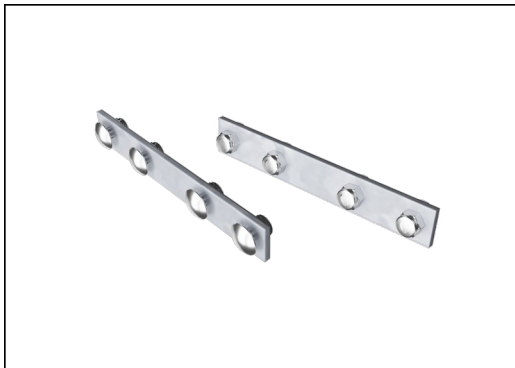

The hardware is made of stainless steel or galvanized steel to ensure durable connections with a high corrosion resistance.

Item no. PAR1055-0611

Installation Information

Total installation time	2.7
Excavation volume	0.44 m ³
Concrete volume	0.36 m ³
Footing depth (standard)	62 cm
Shipment weight	90 kg
Anchoring options	In-ground ✓

Warranty Information

Hot dip galvanised steel	Lifetime
Pinewood	10 years
Spare parts guaranteed	10 years
Stainless steel components	Lifetime

Sustainability Data

PAR1055



Cradle to Gate A1-A3	Total CO ₂ emission	CO ₂ e/kg	Recycled materials
	kg CO ₂ e	kg CO ₂ e/kg	%
PAR1055-0611	143.32	1.83	34.03

The overall framework applied for these factors is the Environmental Product Declaration (EPD), which quantifies "environmental information on the life cycle of a product and enable comparisons between products fulfilling the same function" (ISO, 2006). This follows the structure and applies a Life-Cycle Assessment approach to the entire Product stage from raw material through manufacturing (A1-A3))

Kompan A/S
 C.F. Tietgens Boulevard 32C
 DK-5220 Odense SØ
 Denmark



Verification of CO₂ calculation of: Park



Data version no. 2023-10-05

The CO₂ calculation and data are in compliance with the principles of a carbon footprint impact according to the GHG protocol (Greenhouse Gas Protocol), Scope 3, cradle to gate related to all individual components in the product category: "Park" represented by item no.: PAR4070-0001.

(Scope 3 emissions include emission sources in the upstream and downstream value chain).

Date: 30. October 2023 | Valid until: 30. October 2025

Verified by:

Julie Marie Vejsgaard Larsen, LCA & EPD Consultant

Verification based on report: Validation of CO₂ calculation of 9 categories of Kompan product line, version 1.0, prepared by: Bureau Veritas HSE, Denmark: Julie M. V. Larsen.

Publication date: 30. October 2023

By Bureau Veritas HSE
 www.bureauveritas.dk
 +45 7731 1000

