

# Parallel Bars

FSW201

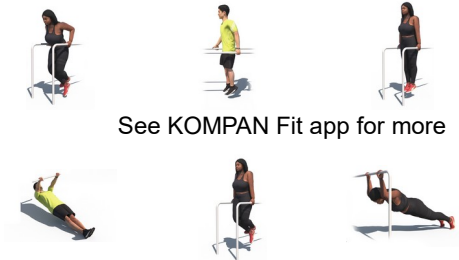

Item no. FSW20100-0901	
<b>General Product Information</b>	
Dimensions LxWxH	196x64x107 cm
Age group	13+
Play capacity (users)	2
Colour options	



See KOMPAN Fit app for more



Street workout is a physical activity that symbolises the freedom of movement and encourages socialising. It is a combination of athletics, calisthenics and other sports, and mostly performed in the public space. A Parallel Bar can be found on every street workout area to train the upper body and core stability. The Parallel Bar fits really well in an Obstacle

Course. The rounded corners make it easy to swing your legs across the Parallel Bars, making it safe to try new tricks without the risk of injuries.

# Parallel Bars

FSW201



Post are made of Ø101.6 x 2mm, pre-galvanized carbon steel and powder coated, a great protection to all conditions.



The connectors are made of die-cast aluminium, specially alloyed for the outdoor environments and heavy usage. The screws attaching the connectors are stainless steel and protected by zinc washers.



Bars intended as grips during exercises are made of hot-dip galvanised steel ø38mm. A great diameter to support the wrist when doing dips or handstands.

Item no. FSW20100-0901

### Installation Information

Max. fall height	107 cm
Safety surfacing area	15.5 m <sup>2</sup>
Total installation time	2.6
Excavation volume	0.11 m <sup>3</sup>
Concrete volume	0.06 m <sup>3</sup>
Footing depth (standard)	90 cm
Shipment weight	80 kg
Anchoring options	In-ground ✓ Surface ✓

### Warranty Information

Connectors	10 years
Hot dip galvanised steel	Lifetime
Post	10 years
Spare parts guaranteed	10 years



All KOMPAN fitness products are compliant with the ASTM F3101 & EN16630 Outdoor Fitness Standards. Load tests are performed as a static test by adding dynamic factors as well as safety factors to the specified load of 78kg per user. A product intended for 1 user is loaded with 420kg.



The information sign is made of a PA6 (Polyamide) and shows the most relevant exercise and a QR code. When scanned the QR code will link to an animated illustration of the exercise and offers the possibility of downloading the KOMPAN sport & fitness App, which will provide a large amount of exercises and workouts.



KOMPAN fitness products are standard available in Orange, Anthracite Grey, Medium Grey, Dark Grey, Night Sky Blue, Light Blue, Yellow, Red, Black, Moss Green, Lime Green, Medium Green, Sand and Nut Brown. All other RAL colours are available on request. It will always be possible to match the surroundings or colour theme!



# Sustainability Data

FSW201



Cradle to Gate A1-A3	Total CO <sub>2</sub> emission	CO <sub>2</sub> e/kg	Recycled materials
	kg CO <sub>2</sub> e	kg CO <sub>2</sub> e/kg	%
<b>FSW20100-0901</b>	190.13	3.38	48.10

The overall framework applied for these factors is the Environmental Product Declaration (EPD), which quantifies "environmental information on the life cycle of a product and enable comparisons between products fulfilling the same function" (ISO, 2006). This follows the structure and applies a Life-Cycle Assessment approach to the entire Product stage from raw material through manufacturing (A1-A3))

**Kompan A/S**  
 C.F. Tietgens Boulevard 32C  
 DK-5220 Odense SØ  
 Denmark



## Verification of CO<sub>2</sub> calculation of: Fitness



Data version no. 2023-10-05

The CO<sub>2</sub> calculation and data are in compliance with the principles of a carbon footprint impact according to the GHG protocol (Greenhouse Gas Protocol), Scope 3, cradle to gate related to all individual components in the product category: "Fitness" represented by item no.: FAZ10100-0900.

(Scope 3 emissions include emission sources in the upstream and downstream value chain).

**Date: 30. October 2023 | Valid until: 30. October 2025**

Verified by:

Julie Marie Vejsgaard Larsen, LCA & EPD Consultant

Verification based on report: Validation of CO<sub>2</sub> calculation of 9 categories of Kompan product line, version 1.0, prepared by: Bureau Veritas HSE, Denmark: Julie M. V. Larsen.

**Publication date: 30. October 2023**

By Bureau Veritas HSE  
 www.bureauveritas.dk  
 +45 7731 1000



# Parallel Bars

FSW201

\* Max fall height | \*\* Total height | \*\*\* Safety surfacing area

\* Max fall height | \*\* Total height

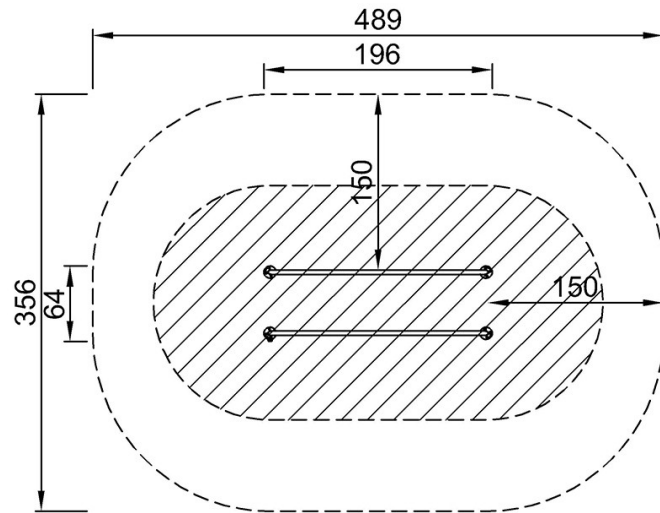

FSW20100  
\*107cm  
\*\*107cm  
\*\*\*15.5m<sup>2</sup>

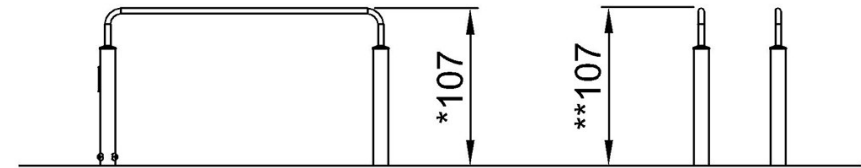

FSW20100

[Click to see TOP VIEW](#)

[Click to see SIDE VIEW](#)