

# Propeller Plane

NRO564



Item no. NRO564-0621

## General Product Information

|                       |   |
|-----------------------|---|
| Dimensions LxWxH      | 397x336x148 cm  |
| Age group             | 2+  |
| Play capacity (users) | 12  |
| Colour options        |   |

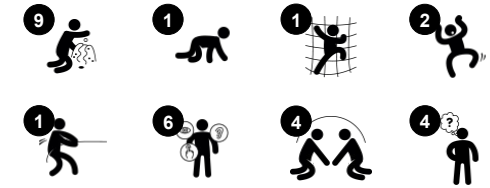

The Propeller Plane is an irresistible attraction for dramatic and active play for younger children. The rich variety of climb and crawl activities attracts and ensures physical activity that trains important motor skills and major muscles. Climbing and crawling trains cross-body coordination, which adds to motor and muscle control. The inclined net makes for a

secure, yet fun climb up and down. The varied cross-body coordination stimulations ultimately builds cross-modal perception which supports e.g reading skills. The rich variety of manipulative activities both on elevated and ground level support the dramatic play scenarios and the play duration. Dramatic play is the favorite play type for younger children,

and it helps build communication and language skills as well as empathy and understanding of the world.



# Propeller Plane

NRO564



## Theme

**Cognitive:** suggests a theme and supports dramatic play, which stimulates language and communication skills.



## Turning wheel

**Social-Emotional:** develops turn-taking, communication and cooperation. **Cognitive:** the manipulative item stimulates 'cause and effect' understanding, logical thinking and communication. **Creative:** working with moveable play items that can leave a mark supports the child's creativity.



## Funnel

**Social-Emotional:** trains cooperation and turn-taking as children put materials into the funnel. **Cognitive:** the passing of materials through funnels supports the children's logical thinking and for younger children the understanding of object permanence: that materials don't vanish but run through at the other end.



## Climbing net

**Physical:** the inclined net supports the upward climbing movement of the body. The net supports cross-body coordination, which impacts coordination of the right and left part of brain, fundamental for other skills such as the ability to read. The asymmetry of the net challenges the children's climbing.



## Switch

**Cognitive:** an understanding of cause and effect is developed when pushing something that moves. The light switch supports dramatic play, and stimulates language skills.

# Propeller Plane

NRO564



All organic Robinia products by KOMPAN are made of Robinia wood which is sourced from sustainable plantation farms. On request it can be supplied as FSC® Certified (FSC® C004450).



The paint used for coloured components is water-based, which is environmentally friendly and has excellent UV resistance. The paint is compliant with Australian Standards.



The Robinia products come in a number of standard colour options. The wood can also be supplied as untreated or with brown painted with a pigment that maintains the wood colour.



There are multiple footing options for all products: Surface anchoring with steel footings and expansion bolts, or wood in-ground or steel in-ground footings.



Panels of 19mm EcoCore™. EcoCore™ is a highly durable, eco-friendly material, which is not only recyclable after use but also consists of a core produced from 100% recycled material.



The Robinia wood can be supplied as untreated raw wood, painted with a brown coloured transparent pigment that maintains the golden wood colour or in a coloured version where selected components are painted in different colours.

Item no. NRO564-0621

### Installation Information

|                          |                          |
|--------------------------|--------------------------|
| Max. fall height         | 50 cm                    |
| Safety surfacing area    | 32.4 m <sup>2</sup>      |
| Total installation time  | 17.8                     |
| Excavation volume        | 1.25 m <sup>3</sup>      |
| Concrete volume          | 0.00 m <sup>3</sup>      |
| Footing depth (standard) | 65 cm                    |
| Shipment weight          | 794 kg                   |
| Anchoring options        | Surface ✓<br>In-ground ✓ |

### Warranty Information

|                       |          |
|-----------------------|----------|
| EcoCore HDPE          | Lifetime |
| Galvanised Steel      | Lifetime |
| Robinia Wood          | 15 years |
| Spare Parts Guarantee | 10 years |
| Stainless Steel Slide | 10 years |



# Sustainability Data

NRO564



| Cradle to Gate A1-A3 | Total CO <sub>2</sub> emission | CO <sub>2</sub> e/kg    | Recycled materials |
|----------------------|--------------------------------|-------------------------|--------------------|
|                      | kg CO <sub>2</sub> e           | kg CO <sub>2</sub> e/kg | %                  |
| <b>NRO564-0621</b>   | 307.23                         | 0.53                    | 6.38               |

The overall framework applied for these factors is the Environmental Product Declaration (EPD), which quantifies "environmental information on the life cycle of a product and enable comparisons between products fulfilling the same function" (ISO, 2006). This follows the structure and applies a Life-Cycle Assessment approach to the entire Product stage from raw material through manufacturing (A1-A3))

**Kompan A/S**  
 C.F. Tietgens Boulevard 32C  
 DK-5220 Odense SØ  
 Denmark



## Verification of CO<sub>2</sub> calculation of: Nature play



Data version no. 2023-10-05

The CO<sub>2</sub> calculation and data are in compliance with the principles of a carbon footprint impact according to the GHG protocol (Greenhouse Gas Protocol), Scope 3, cradle to gate related to all individual components in the product category: "Nature play" represented by item no.: NRO409-0621.

(Scope 3 emissions include emission sources in the upstream and downstream value chain).

**Date: 30. October 2023 | Valid until: 30. October 2025**

**Verified by:**

Julie Marie Vejsgaard Larsen, LCA & EPD Consultant

Verification based on report: Validation of CO<sub>2</sub> calculation of 9 categories of Kompan product line, version 1.0, prepared by: Bureau Veritas HSE, Denmark: Julie M. V. Larsen.

**Publication date: 30. October 2023**

**By Bureau Veritas HSE**  
 www.bureauveritas.dk  
 +45 7731 1000



# Propeller Plane

NRO564

\* Max fall height | \*\* Total height | \*\*\* Safety surfacing area

\* Max fall height | \*\* Total height

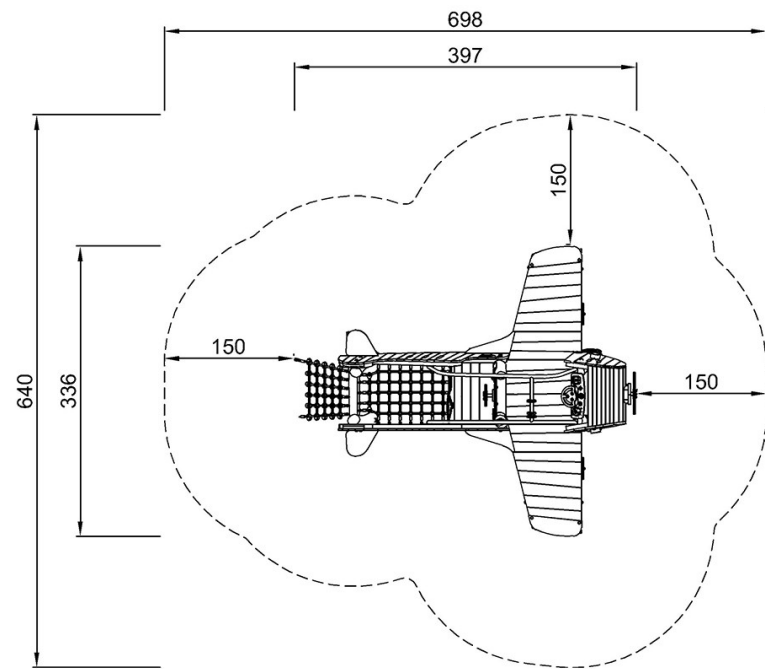

NRO564  
\*50cm  
\*\*148cm  
\*\*\*32.4m<sup>2</sup>

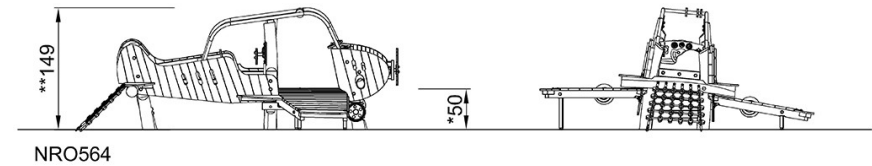

NRO564

[Click to see TOP VIEW](#)

[Click to see SIDE VIEW](#)