

Leg Lift & Pull Up

FSW238

KOMPAN
Let's play



Item no. FSW23800-0901	
General Product Information	
Dimensions LxWxH	117x110x240 cm
Age group	13+
Play capacity (users)	2
Color options	

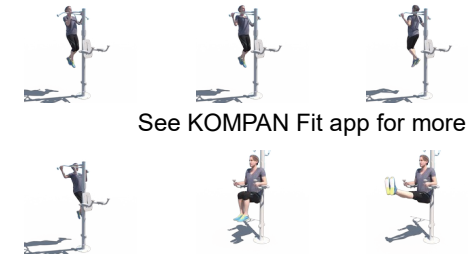

This product provides an enormous amount of exercises on the square meter by combining the leg lift station and pull up bar. The Leg Lift Station is an excellent piece of equipment for ab workouts. it allows users to exercise their abdominal muscles by performing leg lifts while holding themselves up in the chair. Exercising in this manner targets

all of the abdominal muscles. Pull ups are an essential part of a strength training. The Pull Up bar offers a range of exercises, featuring multiple grips for different hand positions. By placing the feet on the horizontal bars beginners can decrease their bodyweight during pull ups and work their way up to advanced training. To make sure that

everyone can reach the pull up bar there is a stepping pod.

Leg Lift & Pull Up

FSW238



The connectors are made of die-cast aluminium, specially alloyed for the outdoor environments and heavy usage. The screws attaching the connectors are stainless steel and protected by zinc washers.



The information sign is made of a PA6 (Polyamide) and shows the most relevant exercise and a QR code. When scanned the QR code will link to an animated illustration of the exercise and offers the possibility of downloading the KOMPAN sport & fitness App, which will provide a large amount of exercises and workouts.



Post are made of Ø101.6 x 2mm, pre-galvanized carbon steel and powder coated, a great protection to all conditions.

Item no. FSW23800-0901

Installation Information

Max. fall height	132 cm
Safety surfacing area	13.9 m ²
Total installation time	3.8
Excavation volume	0.23 m ³
Concrete volume	0.12 m ³
Footing depth (standard)	90 cm
Shipment weight	82 kg
Anchoring options	



Steps are made of extruded aluminium with a non-skid surface. Aluminium has high corrosion resistance and ensures durability of the product. Steps have been mounted at heights of 34,7cm and 54,7cm this creates an easy access to reach the overhead activity



The frame of the leg lift is made from Ø38 x 2mm HDG steel tube. The support plates are made from 15mm Ekogrip®, a 15 mm PE plate with a 3 mm top-layer of thermoplastic rubber with non-skid effect. The arm supports are 110 x 195mm, 580mm apart, and 1315mm above ground. The back support is 335 x 500mm. The opening in the back is 30 x 350mm.



The pull up bar is made from Ø32 mm HDG steel bar. The bar is 1080mm wide and 2300mm above ground



Sustainability Data

FSW238



Cradle to Gate A1-A3	Total CO ₂ emission	CO ₂ e/kg	Recycled materials
	kg CO ₂ e	kg CO ₂ e/kg	%
FSW23800-0901	179.40	3.16	45.10

The overall framework applied for these factors is the Environmental Product Declaration (EPD), which quantifies "environmental information on the life cycle of a product and enable comparisons between products fulfilling the same function" (ISO, 2006). This follows the structure and applies a Life-Cycle Assessment approach to the entire Product stage from raw material through manufacturing (A1-A3))

Kompan A/S
C.F. Tietgens Boulevard 32C
DK-5220 Odense SØ
Denmark



Verification of CO₂ calculation of: Fitness



Data version no. 2023-10-05

The CO₂ calculation and data are in compliance with the principles of a carbon footprint impact according to the GHG protocol (Greenhouse Gas Protocol), Scope 3, cradle to gate related to all individual components in the product category: "Fitness" represented by item no.: FAZ10100-0900.

(Scope 3 emissions include emission sources in the upstream and downstream value chain).

Date: 30. October 2023 | Valid until: 30. October 2025

Verified by:

Julie Marie Vejsgaard Larsen, LCA & EPD Consultant

Verification based on report: Validation of CO₂ calculation of 9 categories of Kompan product line, version 1.0, prepared by: Bureau Veritas HSE, Denmark: Julie M. V. Larsen.

Publication date: 30. October 2023

By Bureau Veritas HSE
www.bureauveritas.dk
+45 7731 1000



Leg Lift & Pull Up

FSW238

* Max fall height | ** Total height | *** Safety surfacing area

* Max fall height | ** Total height

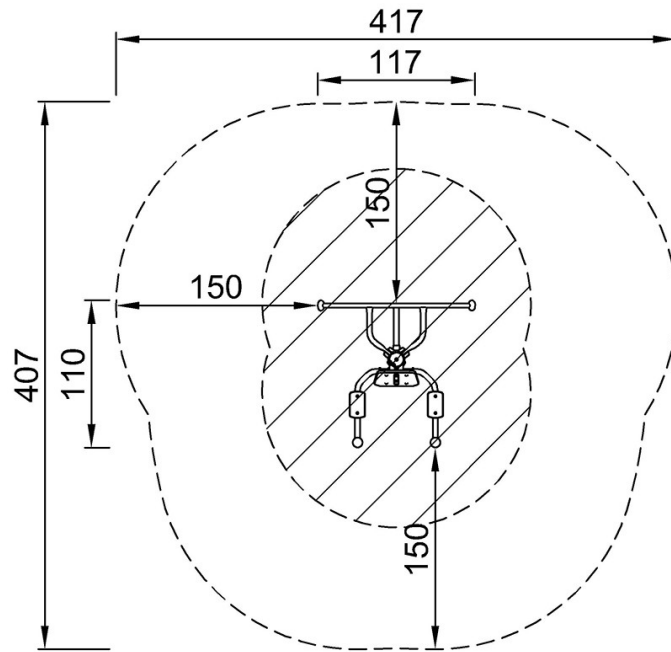

FSW23800
*132cm
**240cm
***13.9m²

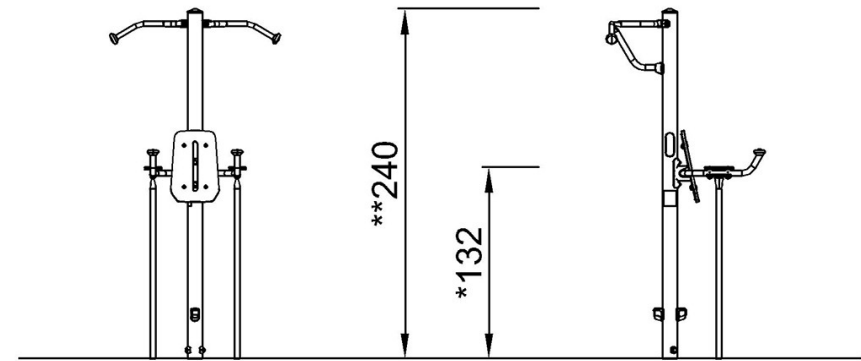

FSW23800

[Click to see TOP VIEW](#)

[Click to see SIDE VIEW](#)