

Red Firetruck

PCM52021

KOMPAN
Let's play



Item no. PCM52021-0901

General Product Information

Dimensions LxWxH	363x150x167 cm
Age group	2+
Play capacity (users)	10
Color options	



The lovely Red Firetruck is a magnet for dramatic play scenarios for all. It will attract children again and again. The rich variety of tactile details support the fire engine play, encouraging children to explore, imagine play stories and cooperate on them. This all stimulates children's vocabulary and their ability to socialize, negotiate and turn-take. The

tactile activities are both inside and outside the truck, and the accessibility of the steering wheel as well as the efficient loop of the inclined climbing wall and slide makes it easy for young children and children with mobility issues to enter the platform and slide to the ground, with or without assistance. Sliding is a fine training of essential muscles and motor

skills: trunk stability and the senses of balance and space are trained when children slide. All in all, children will love this unit and its appealing theme and play activities.



Red Firetruck

PCM52021



Rock climber

Physical: supports cross coordination and leg, arm and hand strength. **Social-Emotional:** the inclination makes climbing feel secure, especially for younger children.



Theme

Cognitive: suggests a theme and supports dramatic play, which stimulates language and communication skills.

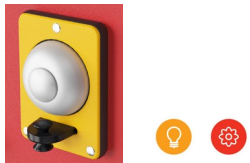

Bell

Cognitive: understanding cause and effect when ringing bell. **Creative:** leaving a mark in creating a sound rhythm when ringing or knocking the bell.



Gear shift

Social-Emotional: cooperation, turn-taking, sharing. **Cognitive:** suggests a theme and supports dramatic play, which stimulates languages skills.

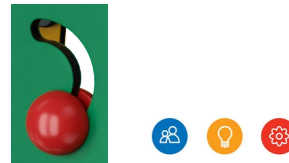

Play sphere

Social-Emotional: can be played from both sides, encouraging cooperation. **Cognitive:** cause and effect understanding. **Creative:** leave a mark and place the spheres at different positions.



Slide

Physical: sliding develops spatial awareness and a sense of balance. Furthermore, the core muscles are trained when sitting upright going down. **Social-Emotional:** empathy stimulated by turn-taking. **Cognitive:** young children develop their understanding of space, speed and distances when sliding down quickly.



Switch

Cognitive: an understanding of cause and effect is developed when pushing something that moves. The theme of light switch supports dramatic play, which is known to stimulate language skills.

Red Firetruck

PCM52021



Panels of 19mm EcoCore™. EcoCore™ is a highly durable, eco friendly material, which is not only recyclable after use, but also consists of material produced from +95% recycled post consumer material from food packing waste.



Main posts with hot dip galvanized steel footing are available in different materials: Pre-galvanized inside and outside with powder coated top finish steel posts. Lead free aluminum with color anodized top finish. TexMade posts of 95% post-consumer recycled PE and textile waste.



All decks are supported by unique designed low-carbon aluminum profiles with multiple attachment options. The grey colored molded decks are made of 75% post-consumer waste PP material with a non-skid pattern and texture surface.

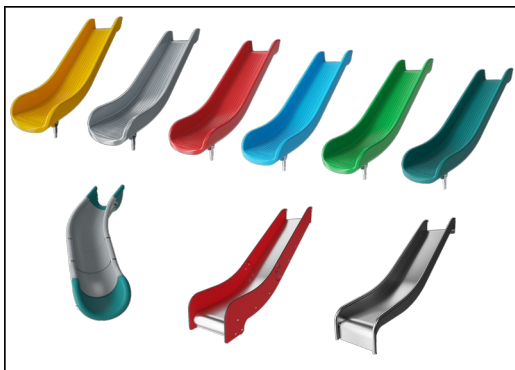

The slides can be chosen in six different colors and three materials: Straight or curved one-piece molded PE slides, made from 33% recycled post-consumer materials in different colours. Combined EcoCore™ sides and stainless-steel. Full stainless steel in one piece design for more vandalism proof solutions.



KOMPAN GreenLine versions are designed with ultimate environmentally friendly materials with lowest possible CO2e emission factor. TexMade post, EcoCore™ panels of 95% post-consumer recycled waste and molded PP decks.

Item no. PCM52021-0901

Installation Information

Max. fall height	58 cm
Safety surfacing area	22.6 m ²
Total installation time	15.5
Excavation volume	0.49 m ³
Concrete volume	0.00 m ³
Footing depth (standard)	90 cm
Shipment weight	425 kg
Anchoring options	Surface ✓ In-ground ✓

Warranty Information

EcoCore HDPE	Lifetime
Hot dip galvanised steel	Lifetime
Post	10 years
PP Decks	10 years
Spare parts guaranteed	10 years

Sustainability Data

PCM52021



Cradle to Gate A1-A3	Total CO ₂ emission	CO ₂ e/kg	Recycled materials
	kg CO ₂ e	kg CO ₂ e/kg	%
PCM52021-0901	447.47	1.46	75.95

The overall framework applied for these factors is the Environmental Product Declaration (EPD), which quantifies "environmental information on the life cycle of a product and enable comparisons between products fulfilling the same function" (ISO, 2006). This follows the structure and applies a Life-Cycle Assessment approach to the entire Product stage from raw material through manufacturing (A1-A3))

Kompan A/S
 C.F. Tietgens Boulevard 32C
 DK-5220 Odense SØ
 Denmark



Verification of CO₂ calculation of: Play systems



Data version no. 2023-10-05

The CO₂ calculation and data are in compliance with the principles of a carbon footprint impact according to the GHG protocol (Greenhouse Gas Protocol), Scope 3, cradle to gate related to all individual components in the product category: "Play systems" represented by item no.: PCM200321-0950.

(Scope 3 emissions include emission sources in the upstream and downstream value chain).

Date: 30. October 2023 | Valid until: 30. October 2025

Verified by:

Julie Marie Vejsgaard Larsen, LCA & EPD Consultant

Verification based on report: Validation of CO₂ calculation of 9 categories of Kompan product line, version 1.0, prepared by: Bureau Veritas HSE, Denmark: Julie M. V. Larsen.

Publication date: 30. October 2023

By Bureau Veritas HSE
 www.bureauveritas.dk
 +45 7731 1000



Red Firetruck

PCM52021

* Max fall height | ** Total height | *** Safety surfacing area

* Max fall height | ** Total height

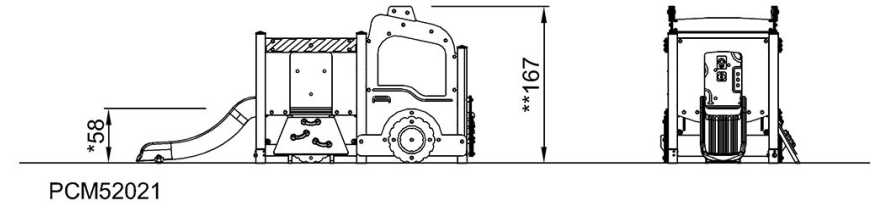
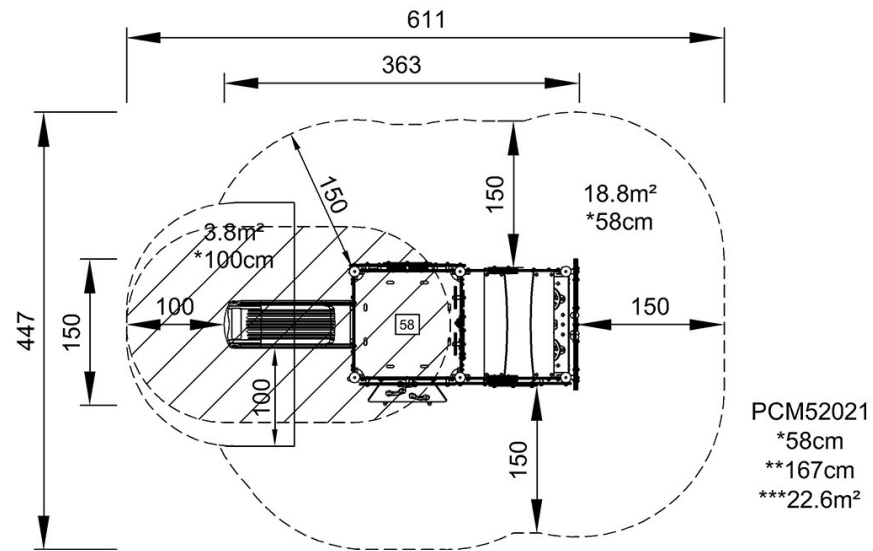

[Click to see TOP VIEW](#)

[Click to see SIDE VIEW](#)