

# Free Runner

FSW242



Item no. FSW24200-0902	
<b>General Product Information</b>	
Dimensions LxWxH	133x64x141 cm
Age group	13+
Play capacity (users)	1
Color options	



The Free Runner, designed for fun and easy exercise, enhances hip mobility, leg coordination, and core stability. Joint-friendly, it suits seniors, rehabilitation, or warming up. Offering three modes of use—alternating leg movements, single leg swings, and synchronized leg motion—it's particularly beneficial for core exercises. The equipment

features broad, stable foot plates and a substantial support rail, ensuring safety and ease of use for all.

# Free Runner

FSW242



The Steel posts are made of Ø101,6x2,0mm pre-galvanized steel tube. The posts are powder coated, corrosion class C3 according to ISO12944-2.

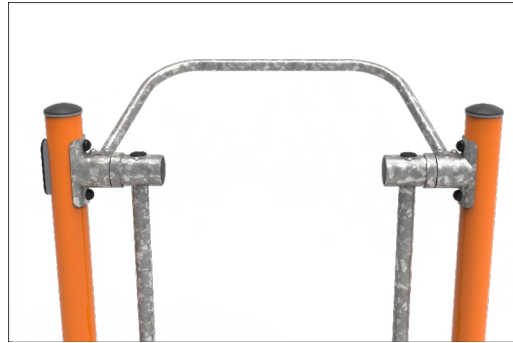

Safety bar is made of tubing with a diameter of 38 mm and wall thickness of 2 mm made of steel S235 with a hot dip galvanized surface treatment according to ISO1461 with a lead content below 90ppm for surfaces and for base material below 100ppm and with powder coated top finish.



The arms for the foot pedals are 855mm long, and made from ø48,3x4mm S235JR hot dip galvanized steel tube.

Item no. FSW24200-0902

### Installation Information

Max. fall height	85 cm
Safety surfacing area	19.0 m <sup>2</sup>
Total installation time	3.2
Excavation volume	0.06 m <sup>3</sup>
Concrete volume	0.04 m <sup>3</sup>
Footing depth (standard)	90 cm
Shipment weight	105 kg
Anchoring options	In-ground ✓ Surface ✓

### Warranty Information

Bearings assembly	5 years
EcoCore HDPE	Lifetime
Spare parts guaranteed	10 years
Steel frame	10 years



The product must feature an information sign with related exercises, and each exercise must feature a QR code linking to its related exercise portal in an app that offers support on the specific exercise. The sign must additionally offer a QR code for downloading the app.



Heavy duty engineered bearing system with single row deep groove ball bearings with rubber seals. The fully closed bearing construction is lifetime lubricated and maintenance free.



Footholds of 19mm EcoCore™ HDPE. EcoCore™ is a highly durable, eco friendly material, which is not only recyclable after use, but also consists of material produced from +95% recycled post consumer material from food packing waste.

**EN**  
**16630**  
compliant

# Sustainability Data

FSW242



Cradle to Gate A1-A3	Total CO <sub>2</sub> emission	CO <sub>2</sub> e/kg	Recycled materials
	kg CO <sub>2</sub> e	kg CO <sub>2</sub> e/kg	%
<b>FSW24200-0902</b>	186.80	2.62	51.66

The overall framework applied for these factors is the Environmental Product Declaration (EPD), which quantifies "environmental information on the life cycle of a product and enable comparisons between products fulfilling the same function" (ISO, 2006). This follows the structure and applies a Life-Cycle Assessment approach to the entire Product stage from raw material through manufacturing (A1-A3))

**Kompan A/S**  
C.F. Tietgens Boulevard 32C  
DK-5220 Odense SØ  
Denmark



## Verification of CO<sub>2</sub> calculation of: Fitness



Data version no. 2023-10-05

The CO<sub>2</sub> calculation and data are in compliance with the principles of a carbon footprint impact according to the GHG protocol (Greenhouse Gas Protocol), Scope 3, cradle to gate related to all individual components in the product category: "Fitness" represented by item no.: FAZ10100-0900.

(Scope 3 emissions include emission sources in the upstream and downstream value chain).

**Date: 30. October 2023 | Valid until: 30. October 2025**

**Verified by:**

Julie Marie Vejsgaard Larsen, LCA & EPD Consultant

Verification based on report: Validation of CO<sub>2</sub> calculation of 9 categories of Kompan product line, version 1.0, prepared by: Bureau Veritas HSE, Denmark: Julie M. V. Larsen.

**Publication date: 30. October 2023**

**By Bureau Veritas HSE**  
www.bureauveritas.dk  
+45 7731 1000



# Free Runner

FSW242

\* Max fall height | \*\* Total height | \*\*\* Safety surfacing area

\* Max fall height | \*\* Total height

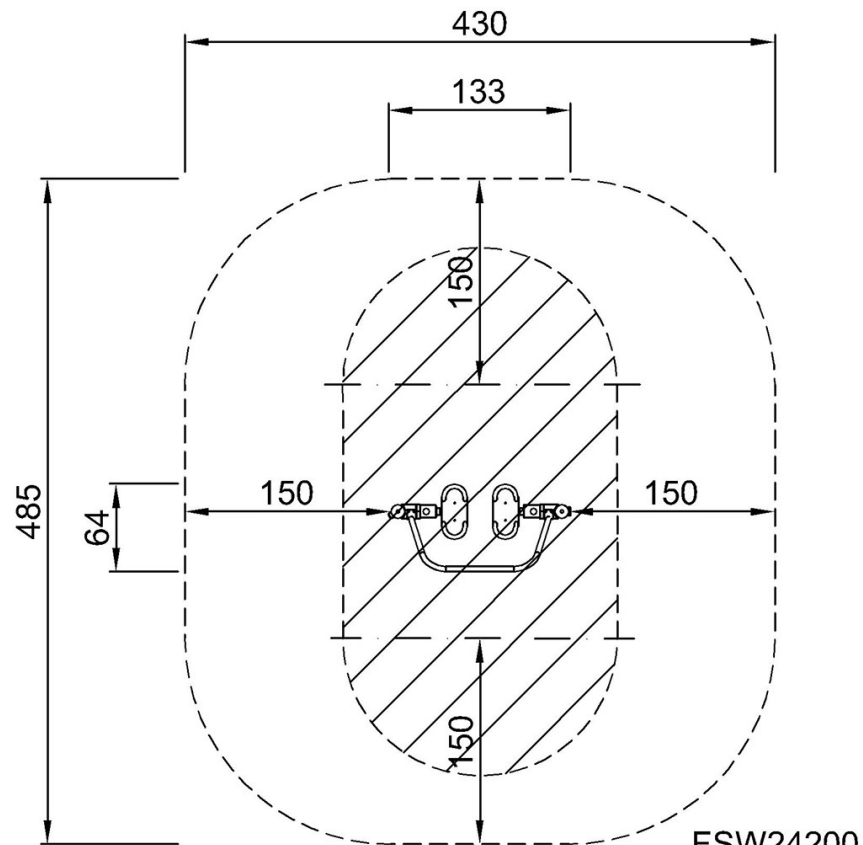

FSW24200

\*85cm  
\*\*141cm  
\*\*\*19m<sup>2</sup>

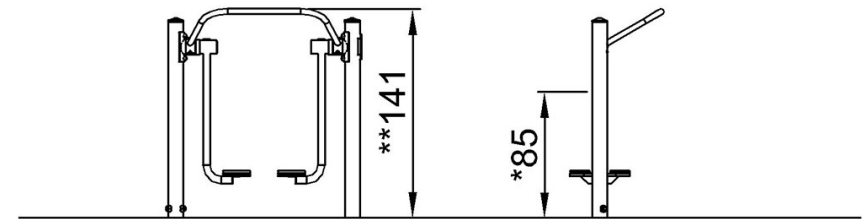

FSW24200

[Click to see TOP VIEW](#)

[Click to see SIDE VIEW](#)