

Squat

FSW40600

KOMPAN[®]



Item no. FSW40600-0001	
General Product Information	
Dimensions LxWxH	125x145x138 cm
Age group	13+
Capacity (users)	1
Color options	

With an adjustable load, the Squat provides essential training for the legs and various supporting muscle groups. The Squat is remarkably easy to use, requiring no adjustments other than the weight load. The bar mimics the movement of a free barbell but in a safer, more controlled manner. The integrated step bench allows shorter users or

those wanting a deeper bottom position to train effectively. The versatile design also makes the machine suitable for a variety of exercises, such as shoulder presses, lunges etc.



Squat

FSW40600

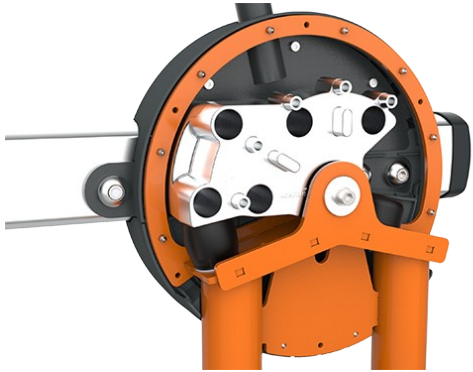

All mechanical stops are fully enclosed within the cover. The adjustable weight, featuring internal end stops and indexed positions, moves on rollers within an enclosed groove in an aluminium profile. As a result, entrapment is not possible, making it extremely safe to use and providing protection against the elements and unwanted abuse.



The weight on each side can be adjusted in 8 steps of 5 kg, providing a training weight from 10 to 80kg. The patent pending system is intuitive to use, eliminating the need for traditional pins that can get lost or stuck. Pull the handle and move the weight to quickly select the desired load.

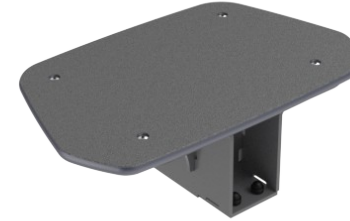

The integrated 20 cm step bench allows shorter users or those wanting a deeper bottom position to train effectively. Varying the foot placement enables multiple exercise variations and targeting different muscle groups.

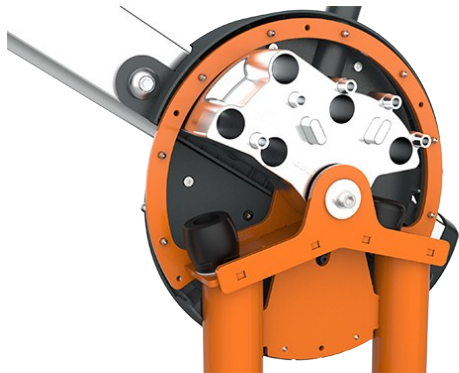

The machine features low operating noise thanks to an internal end stop made from TPE (thermoplastic elastomer). The damper absorbs impact energy from the weight with minimal rebound, reducing noise and vibration and ensuring a quieter, more controlled training experience.

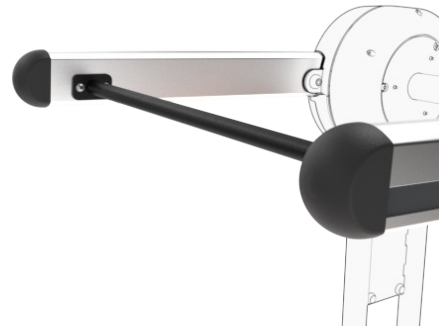

Barbell
The 120 cm high bar mimics the natural movement of a free barbell while offering a safer and more controlled training experience, allowing users to perform a wide range of strength exercises with improved stability and confidence.

The information sign is made of Polycarbonate and shows the most relevant exercise and a QR code. The QR code links to a video of the exercise in the KOMPAN sports & fitness App, which will provide a large amount of exercises and training.

Item no. FSW40600-0001

Installation Information

Max. fall height	20 cm
Safety surfacing area	17.0 m ²
Total installation time	7.3 hours
Excavation volume	0.00 m ³
Concrete volume	0.00 m ³
Footing depth (standard)	0 cm
Shipment weight	368 kg
Anchoring options	

Warranty Information

Galvanised/painted metal	10 years
Aluminum	15 years
Movable parts	2 years
EcoCore HDPE	Lifetime
Spare parts guaranteed	10 years

EN
16630
compliant

Sustainability Data

FSW40600



Independent review certificate

Kompan A/S
C. F. Tietgens Blvd. 32C, 5220 Odense SØ

Bureau Veritas hereby attests that the CO₂e-calculations (covering materials, processing, waste and transport) done by Kompan for "Fitness", meet the requirements set by the listed standard.

Kompan A/S uses a selection of EPDs and emission factors from the Life Cycle Assessment database Ecoinvent 3.11. These values are reported as kg CO₂e, with all other impact categories excluded in line with the scope of ISO 14067:2018. The emission factors cover, material use, manufacturing processes, transport to Kompan, and electricity used during manufacturing. The presented emissions fall under GHG Protocol scope 3 emissions. Scope 1 and 2 are not presented. Scope 3 emissions include emission sources in the upstream value chain of a company, downstream emissions are excluded in this analysis.

Method: ISO 14067:2018 using GHG protocol guidance documents, reported as kg CO₂e.

Object

The verification has been done on the one pager "FAZ10100-0900" version: 27-10-2025. The supporting documentation "KOMPAN data_updated emissions factors_2025_V2" and "Emissions factors, EPD's and ecoinvent 3.11_2025" was also reviewed and approved.

Declaration

The review has been completed as a critical review with a limited assurance. I hereby confirm that nothing has come to the reviewer's attention which would lead to conclude that the study does not give an accurate depiction or isn't completed following method of the CO₂e calculation, the requirements of ISO 14067:2018, and 14071:2024, in the above referenced documentation.

Note: This verification only covers calculation elements according to method described in ISO 14067:2018 and may not be seen as a Life Cycle Assessment according to ISO 14067:2018.

Ref.: Kompan_Verification report 2025, 28-10-2025

Date of certificate: 29-10-2025

Expire date: 29-10-2027

Verified by: Julie Marie Vejsgaard Larsen, Environmental Auditor

Signature: 

Cradle to Gate A1-A3	Total CO ₂ emission	CO ₂ e/kg	Recycled material
	kg CO ₂ e	kg CO ₂ e/kg	%
FSW40600-0001	1,393.89	5.76	45.94

The overall framework applied for these factors is the Environmental Product Declaration (EPD), which quantifies "environmental information on the life cycle of a product and enable comparisons between products fulfilling the same function" (ISO, 2006). This follows the structure and applies a Life-Cycle Assessment approach to the entire Product stage from raw material through manufacturing (A1-A3))

Squat

FSW40600

* Max fall height | ** Total height | *** Safety surfacing area

* Max fall height | ** Total height

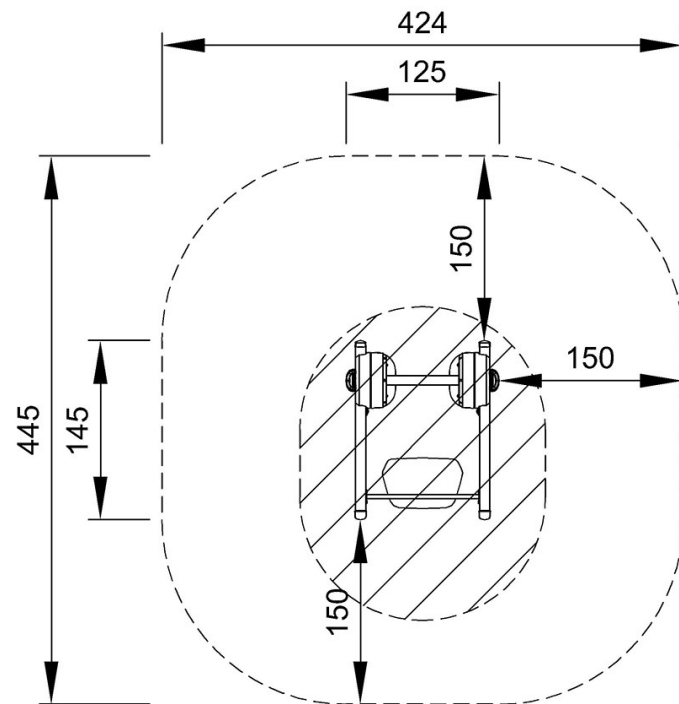

FSW40600
*20cm
**138cm
***17m²

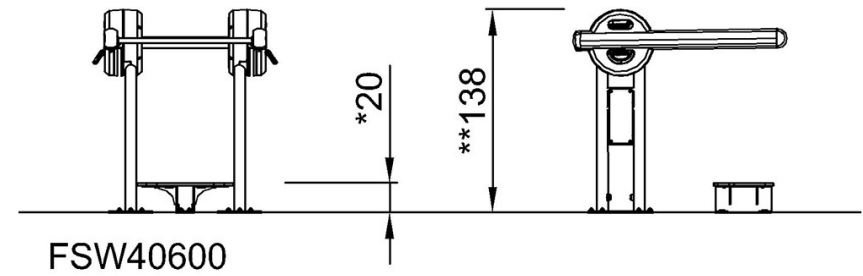

[Click to see TOP VIEW](#)

[Click to see SIDE VIEW](#)