

# Combi Swing H:2.5m, 100cm Shell Seat

KSW90063

**KOMPAN**  
Let's play



Item no. KSW90063-0909	
<b>General Product Information</b>	
Dimensions LxWxH	655x240x274 cm
Age group	2+
Play capacity (users)	8
Colour options	

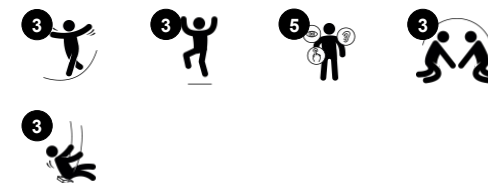

KOMPAN swings can be configured to adapt individual needs & demands. All A-Frame swings are available in 2,0m and 2,5m height with posts of impregnated pine wood, hardwood or hot dip galvanized steel. As seats we offer standard swing seat, cradle seat, toddler seat or bird nests with a diameter of ø100cm or 120cm. Further the seats are

available with either hot dip galvanized chains or stainless steel chains and if preferred with antiwrap suspensions. The modular swing system also enable multibay configurations with 2,3,4 or more sections.



# Combi Swing H:2.5m, 100cm Shell Seat

KSW90063



## Two single swing seats

**Physical:** trains balance, coordination and spatial awareness. All necessary when judging distances. Trains arm, leg and core muscles, and strengthens bone density when jumping off. **Social-Emotional:** parallel play invites cooperation and consideration.

**Cognitive:** cause and effect and thinking skills for younger children. Rules games for bigger children, when swinging in same or different rhythm.



## Shell nest swing

**Physical:** balance, coordination and spatial awareness are developed. The swinging movement trains the arm, leg and core muscles, and strengthens bone density when jumping off. **Social-Emotional:** the spacious seat allows for many children standing, lying, seated together and is inclusive for all.

**Cognitive:** develops cause and effect understanding, rhythm and thinking skills in younger children.

# Combi Swing H:2.5m, 100cm Shell Seat

KSW90063



The A-Frame is designed with hot dip galvanised  $\varnothing 100\text{mm}$  crossbar with large steel end plates for strong fixation of the two post options: Hot dip galvanised  $\varnothing 70\text{mm}$  steel. Impregnated pine wood with hot dip galvanised steel footings.



The swing hangers are made of high quality UV-stabilised nylon (PA6) housing with integrated lifetime sealed ball bearings. The height adjustable chains are fixed by a stainless steel hook with theft proof snake-eye bolt in a turn able anti twist housing. All seats with two chain fixation are available with either standard or anti-wrap suspension.



The post of the A-Frame swings are available for surface anchoring with expansion bolts or inground in 60cm or 90cm depth. The hot dip galvanised steel legs are anchored directly in the ground. Pine wood posts are elevated from ground by a unique profiled hot dip galvanised steel footing.



The standard seats of KOMPAN swings is engineered for maximum safety and durability. The two component seat with a PP inner core and outside rubber is produced in one operation. The seats are available with swing chains of either hot dip galvanised steel or stainless steel for all swings heights.



KOMPAN heavy duty designed swing hangers of stainless steel with anti-twist function. The moving parts of the swing hanger is lifetime sealed and lubricated. The hanger system is equipped with a safety chain to prevent the swing hanger to fall down if damaged.



KOMPAN designed the bird's nest seats to be light in weight and in compliance with global safety standards. The soft, shock absorbent bumpers with non-slip surface makes the swing seat extremely user friendly. Choose between a rope version with reinforced PA rope or a moulded PE version. Both equipped with soft rubber bumpers.

Item no. KSW90063-0909

## Installation Information

Max. fall height	145 cm
Safety surfacing area	40.7 m <sup>2</sup>
Total installation time	6.5
Excavation volume	1.95 m <sup>3</sup>
Concrete volume	0.00 m <sup>3</sup>
Footing depth (standard)	90 cm
Shipment weight	249 kg
Anchoring options	In-ground ✓

## Warranty Information

Chains	10 years
Hot dip galvanised steel	Lifetime
Spare parts guaranteed	10 years
Swing hangers	5 years
Swing seat	10 years



# Sustainability Data

KSW90063



Cradle to Gate A1-A3	Total CO <sub>2</sub> emission	CO <sub>2</sub> e/kg	Recycled materials
	kg CO <sub>2</sub> e	kg CO <sub>2</sub> e/kg	%
<b>KSW90063-0909</b>	694.46	2.87	46.74

The overall framework applied for these factors is the Environmental Product Declaration (EPD), which quantifies "environmental information on the life cycle of a product and enable comparisons between products fulfilling the same function" (ISO, 2006). This follows the structure and applies a Life-Cycle Assessment approach to the entire Product stage from raw material through manufacturing (A1-A3))

**Kompan A/S**  
 C.F. Tietgens Boulevard 32C  
 DK-5220 Odense SØ  
 Denmark



## Verification of CO<sub>2</sub> calculation of: Freestanding play equipment



Data version no. 2023-10-05

The CO<sub>2</sub> calculation and data are in compliance with the principles of a carbon footprint impact according to the GHG protocol (Greenhouse Gas Protocol), Scope 3, cradle to gate related to all individual components in the product category: "Freestanding play equipment" represented by item no.: KSW92011-0910.

(Scope 3 emissions include emission sources in the upstream and downstream value chain).

**Date: 30. October 2023 | Valid until: 30. October 2025**

Verified by:

Julie Marie Vejsgaard Larsen, LCA & EPD Consultant

Verification based on report: Validation of CO<sub>2</sub> calculation of 9 categories of Kompan product line, version 1.0, prepared by: Bureau Veritas HSE, Denmark: Julie M. V. Larsen.

**Publication date: 30. October 2023**

By Bureau Veritas HSE  
 www.bureauveritas.dk  
 +45 7731 1000



# Combi Swing H:2.5m, 100cm Shell Seat

KSW90063

\* Max fall height | \*\* Total height | \*\*\* Safety surfacing area

\* Max fall height | \*\* Total height

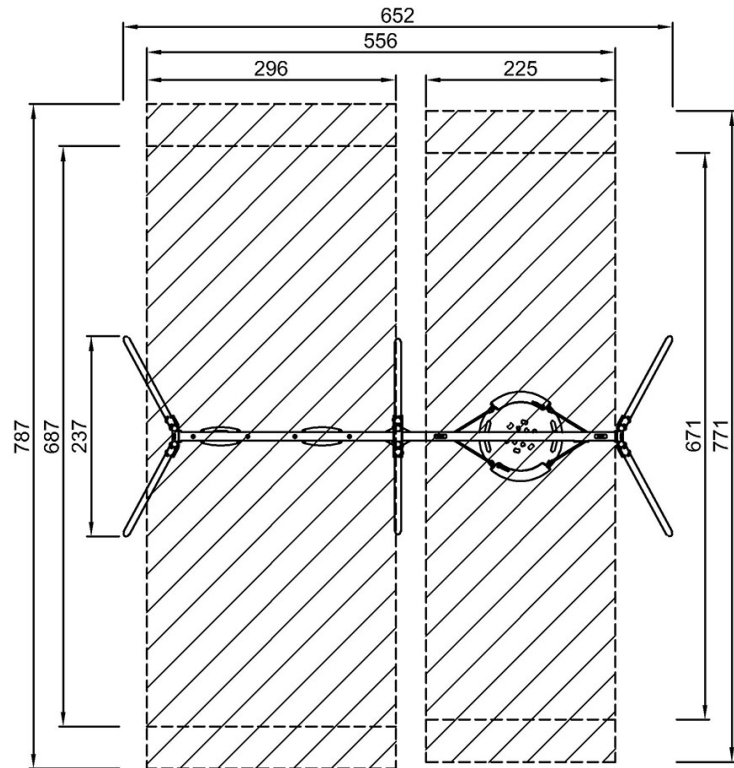

KSW90063  
\*145cm  
\*\*271cm  
\*\*\*40.7m<sup>2</sup>

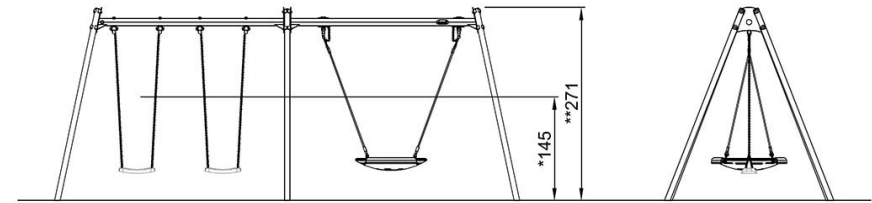

KSW90063

[Click to see TOP VIEW](#)

[Click to see SIDE VIEW](#)