

Chest Press

FSW40100

KOMPAN[®]



产品编号 FSW40100-0001

产品信息概览

长宽高尺寸	125x127x109 cm
适用年龄段	13+
容纳人数	1
颜色选择	



With adjustable load, the Chest Press provides effective weight training for the chest, triceps, and front shoulder muscles. The user-friendly handles with multi-function grips allow for many exercise variations and perfect ergonomics for users of different heights. The Chest Press is designed with safety in mind; all mechanical stops are placed inside the cover

to eliminate the risk of crush points.

Chest Press

FSW40100

KOMPAN

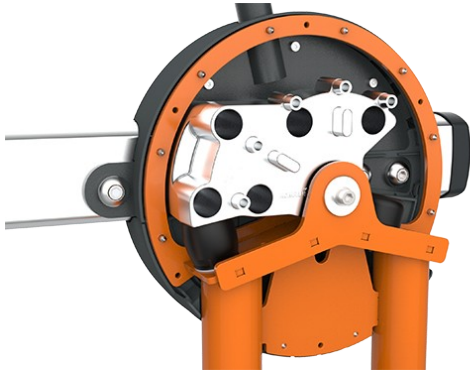

All mechanical stops are fully enclosed within the cover. The adjustable weight, featuring internal end stops and indexed positions, moves on rollers within an enclosed groove in an aluminium profile. As a result, entrapment is not possible, making it extremely safe to use and providing protection against the elements and unwanted abuse.



The weight on each side can be adjusted in 8 steps of 5 kg, providing a training weight from 10 to 80kg. The patent pending system is intuitive to use, eliminating the need for traditional pins that can get lost or stuck. Pull the handle and move the weight to quickly select the desired load.



The seat and backrest is made of blowmolded PE and mounted directly onto the steel frame, making it highly durable and resistant to wear and tear. Its ergonomic design helps reduce strain on the spine during exercise. Additionally, the seat is positioned at a height of 45 cm that makes the transfer from a wheelchair easy.

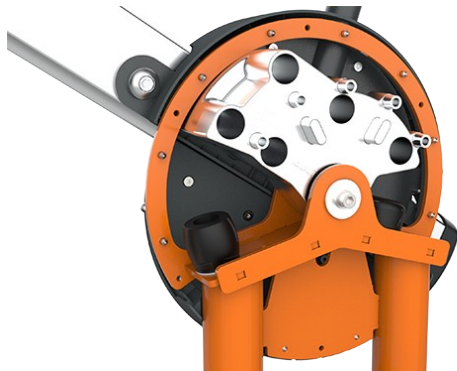

The machine features low operating noise thanks to an internal end stop made from TPE (thermoplastic elastomer). The damper absorbs impact energy from the weight with minimal rebound, reducing noise and vibration and ensuring a quieter, more controlled training experience.



The ergonomically shaped handles feature multiple grip areas to support adaptable training. This allows users between 140–205 cm in height to perform exercises with correct ergonomics while enabling a wide variety of exercises that target different muscle groups. The handles are made from cast aluminium with a grip texture finish.



The unilateral movement design ensures that each arm works independently, preventing compensation by the stronger side. The independent movement also allows for greater flexibility, enabling multiple exercise variations and supporting inclusive training for users of different abilities.

产品编号 FSW40100-0001

安装信息

最大跌落高度	46 cm
安全面积	16.3 m ²
安装总时长	5.4 小时
开挖量	0.00 m ³
混凝土使用量	0.00 m ³
标准入地深度	0 cm
运输重量	287 kg
固定选项	

质保信息

镀锌 / 喷漆金属	10 年
铝	15 年
活动部件	2 年
中空 PE 聚乙烯部件	10 年
承保零部件	10 年

EN
16630
compliant

可持续性数据

FSW40100



从原材料到成品

CO₂ 排放总量

kg CO₂e

CO₂ 排放量 / 千克

kg CO₂e/kg

回收的原料

%

FSW40100-0001

1,267.20

6.59

43.57

这些因素采用的总体框架为环保产品声明 (EPD)，该声明可量化“产品生命周期的环保信息，并对相同功能的产品进行对比” (ISO, 2006)。在遵循该框架的同时，对从原材料到制造的整个产品阶段 (A1-A3) 应用生命周期评估法。



Independent review certificate

Kompan A/S
C. F. Tietgens Blvd. 32C, 5220 Odense SØ

Bureau Veritas hereby attests that the CO₂e-calculations (covering materials, processing, waste and transport) done by Kompan for "Fitness", meet the requirements set by the listed standard.

Kompan A/S uses a selection of EPDs and emission factors from the Life Cycle Assessment database EcoInvent 3.11. These values are reported as kg CO₂e, with all other impact categories excluded in line with the scope of ISO 14067:2018. The emission factors cover, material use, manufacturing processes, transport to Kompan, and electricity used during manufacturing. The presented emissions fall under GHG Protocol scope 3 emissions. Scope 1 and 2 are not presented. Scope 3 emissions include emission sources in the upstream value chain of a company, downstream emissions are excluded in this analysis.

Method: ISO 14067:2018 using GHG protocol guidance documents, reported as kg CO₂e.

Object

The verification has been done on the one pager "FAZ10100-0900" version: 27-10-2025. The supporting documentation "KOMPAN data_updated emissions factors_2025_V2" and "Emissions factors, EPD's and ecoinvent 3.11_2025" was also reviewed and approved.

Declaration

The review has been completed as a critical review with a limited assurance. I hereby confirm that nothing has come to the reviewer's attention which would lead to conclude that the study does not give an accurate depiction or isn't completed following method of the CO₂e calculation, the requirements of ISO 14067:2018, and 14071:2024, in the above referenced documentation.

Note: This verification only covers calculation elements according to method described in ISO 14067:2018 and may not be seen as a Life Cycle Assessment according to ISO 14067:2018.

Ref.: Kompan_Verification report 2025, 28-10-2025

Date of certificate: 29-10-2025

Expire date: 29-10-2027

Verified by: Julie Marie Vejsgaard Larsen, Environmental Auditor

Signature:

Chest Press

FSW40100

KOMPAN®

最大跌落高度 | 总高度 | 安全区域

最大跌落高度 | 总高度

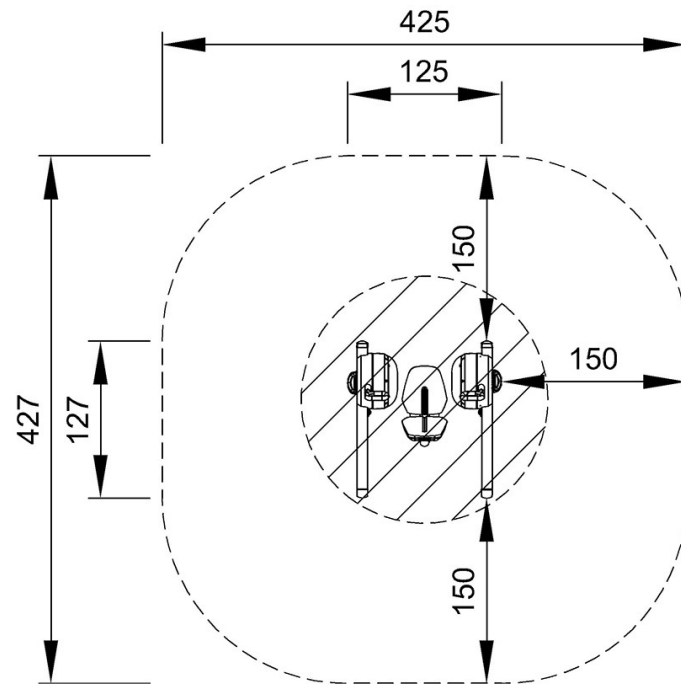

FSW40100
*46cm
**109cm
***16.3m²

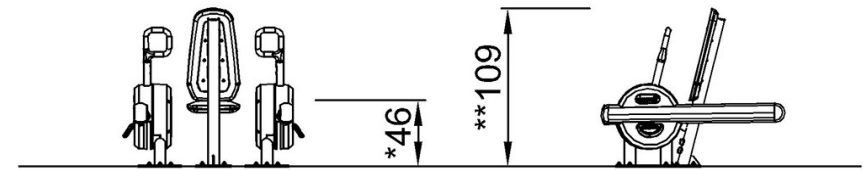

FSW40100

[点击查看俯视图](#)

[点击查看侧面图](#)