



# Maker with Shade

PCE205621



Item no. PCE205621-0903	
General Product Information	
Dimensions LxWxH	707x552x400 cm
Age group	2+
Play capacity (users)	35
Color options	  



Wow! The Maker is a fantastic structure loaded with play, sure to attract children who will want to stay for long playtimes, and return again and again. The play is not only thrilling and challenging but will support children's development in all areas. Sliding supports physical skills such as balance and spatial awareness. Sliding on the double slide makes

for fun, social play. Climbing the membrane climber supports strength and cross-coordination, important skills for physical as well as intellectual development. The varied climbing opportunities provide variety and challenge. Social play is widely supported, especially in the ground level sand play corner with talking tubes and sand funnel. Cognitive

and physical play go together in such features as the curly climber and the music panel. Lots of fun for lots of Wow!



Data is subject to change without prior notice.

# Maker with Shade

PCE205621

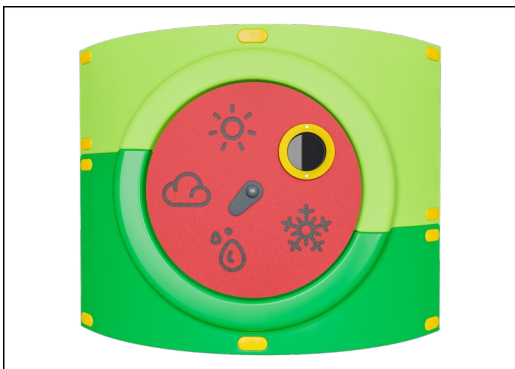

The Curved ELEMENTS panels are moulded of UV stabilised recyclable PE using 33% post-consumer recycled material. With multiple options for in-build play features that also ensures a strong panel solution. Straight panels are made of KOMPAN 19mm HDPE EcoCore™ which is a highly durable, ecofriendly and recyclable material made from +95% PCM.



Sails of commercial 95 high density PE knitted specially for sun-shade structures. The sails are treated with UV stabilizers to ensure a long life-time. The sails are supported by a hot dip galvanised steel frame and tightened by stainless steel devices.

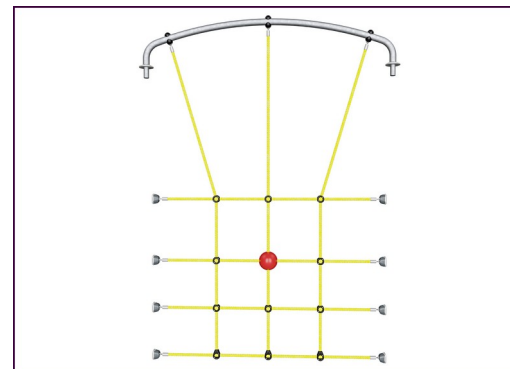

ELEMENTS ropes has six-stranded steel wires and a steel wire core. Each strand is tightly wrapped with PES yarn, which is made from +95% post consumer materials. The yarn is then melted onto each individual strand making the ropes highly wear- and vandalism-resistant.

Item no. PCE205621-0903

### Installation Information

Max. fall height	204 cm
Safety surfacing area	65.6 m <sup>2</sup>
Total installation time	32.5
Excavation volume	0.61 m <sup>3</sup>
Concrete volume	0.14 m <sup>3</sup>
Footing depth (standard)	85 cm
Shipment weight	1,162 kg
Anchoring options	Surface ✓ In-ground ✓



The main posts are made of high quality pregalvanized steel with powder coated top finish. Post tops are closed with caps of UV stabilized nylon (PA6). The grey colored molded decks are made of 75% post-consumer waste PP material with a non-skid pattern and texture surface. All decks are supported by unique designed low-carbon aluminum profiles with multiple attachment options.

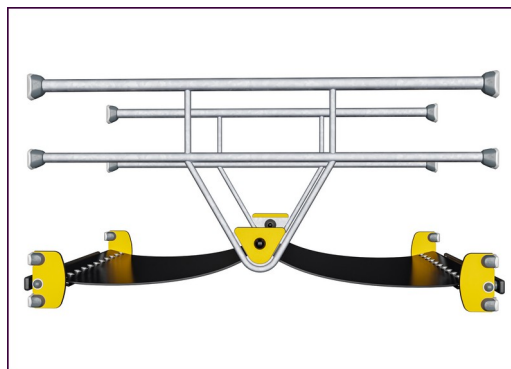

ELEMENTS rubber membranes are conveyor belt made of layers of rubber mixed of natural rubber and SBR rubber, and embedded with layers of armouring made of woven PE and PA. The thickness 8mm ensures high durability in any environment.

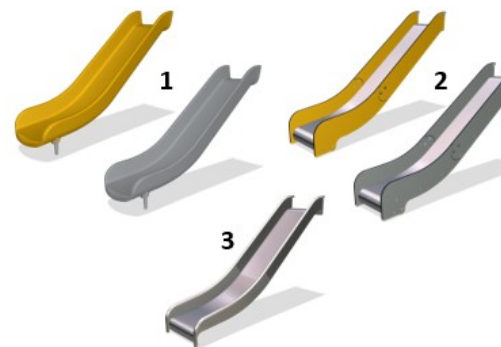

The slides are available in either molded PE made from 33% recycled post-consumer materials in different colors or in full AISI304 stainless steel with a thickness of 2mm.



# Sustainability Data

PCE205621



Cradle to Gate A1-A3	Total CO <sub>2</sub> emission	CO <sub>2</sub> e/kg	Recycled materials
	kg CO <sub>2</sub> e	kg CO <sub>2</sub> e/kg	%
<b>PCE205621-0903</b>	2,578.80	2.92	45.60

The overall framework applied for these factors is the Environmental Product Declaration (EPD), which quantifies "environmental information on the life cycle of a product and enable comparisons between products fulfilling the same function" (ISO, 2006). This follows the structure and applies a Life-Cycle Assessment approach to the entire Product stage from raw material through manufacturing (A1-A3))

**Kompan A/S**  
 C.F. Tietgens Boulevard 32C  
 DK-5220 Odense SØ  
 Denmark



## Verification of CO<sub>2</sub> calculation of: Play systems



Data version no. 2023-10-05

The CO<sub>2</sub> calculation and data are in compliance with the principles of a carbon footprint impact according to the GHG protocol (Greenhouse Gas Protocol), Scope 3, cradle to gate related to all individual components in the product category: "Play systems" represented by item no.: PCM200321-0950.

(Scope 3 emissions include emission sources in the upstream and downstream value chain).

**Date: 30. October 2023 | Valid until: 30. October 2025**

Verified by:

Julie Marie Vejsgaard Larsen, LCA & EPD Consultant

Verification based on report: Validation of CO<sub>2</sub> calculation of 9 categories of Kompan product line, version 1.0, prepared by: Bureau Veritas HSE, Denmark: Julie M. V. Larsen.

**Publication date: 30. October 2023**

By Bureau Veritas HSE  
 www.bureauveritas.dk  
 +45 7731 1000



# Maker with Shade

PCE205621

\* Max fall height | \*\* Total height | \*\*\* Safety surfacing area

\* Max fall height | \*\* Total height

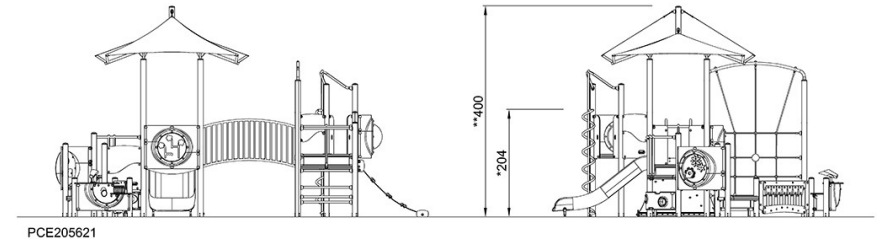
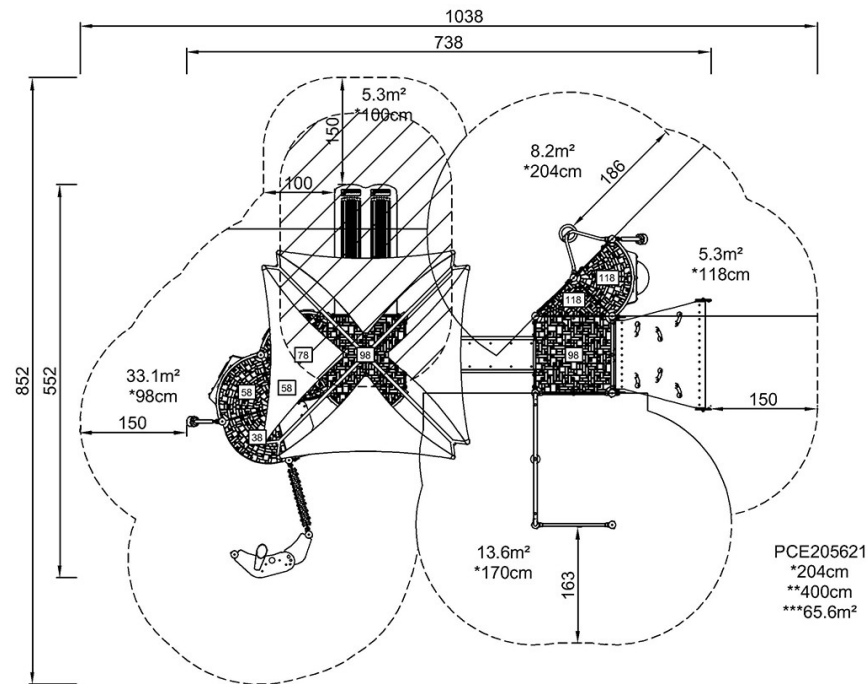

[Click to see TOP VIEW](#)

[Click to see SIDE VIEW](#)