

Anita Picnic Mini - HPL

PAR1404

KOMPANI
Let's play

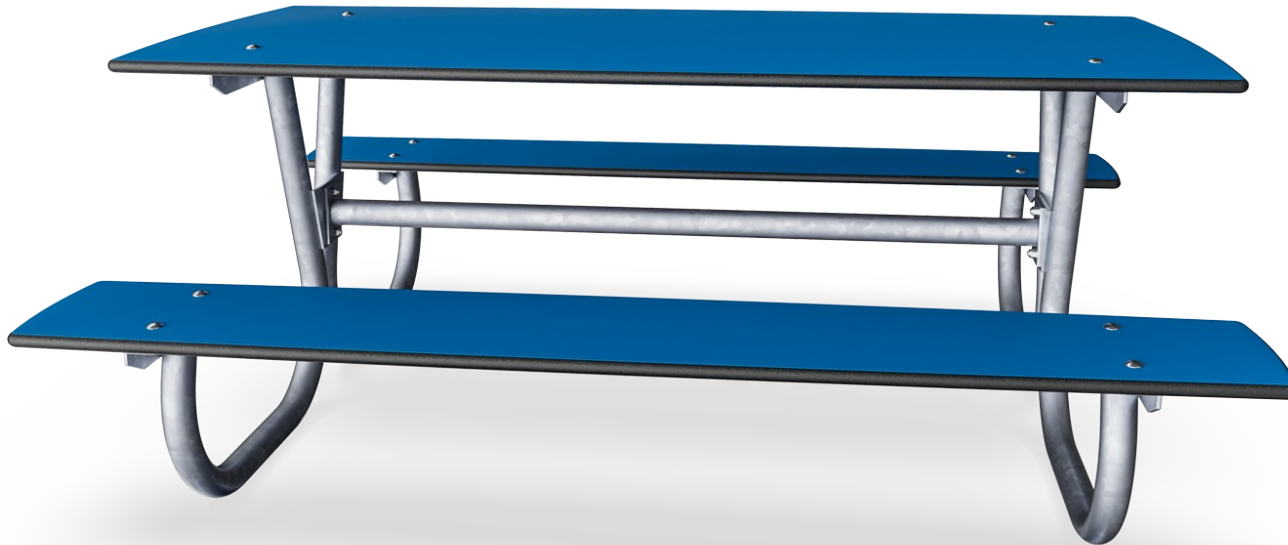

Item no. PAR1404-0002

General Product Information

Dimensions LxWxH	150x124x59 cm
Age group	
Play capacity (users)	
Color options	



Outdoor Furniture plays an essential role in our communities by adding an inviting and social atmosphere, a place to meet, socialise or rest. Anita is classic and comfortable park furniture that invites citizens to take a seat and relax. They blend into and enhance public areas like parks and playgrounds etc. Anita Picnic Blue HPL comes in two sizes with one

aim; an opportunity for adults or children to make that al fresco moment special. The Mini is designed with a seating height suited for children.

Anita Picnic Mini - HPL

PAR1404



All boards are made of High Pressure Laminate HPL with a thickness of 17.8mm according to EN 438-6 and has a nonskid surface texture. The multilayer construction makes the boards durable and suitable for outdoor use with a high UV stability and high resistance to impacts, scratches, fire, water and humidity.



The steel surfaces are hot dip galvanized inside and outside with lead free zinc. The galvanization has excellent corrosion resistance in outdoor environments and require low maintenance.



The furniture is a freestanding product with optional anchoring possibilities. Kompan has multiple anchoring's to fit specific requirements for individual customer projects. The anchoring is sold as separate modules.

Item no. PAR1404-0002

Installation Information

Total installation time	1.3
Excavation volume	0.00 m ³
Concrete volume	0.00 m ³
Footing depth (standard)	0 cm
Shipment weight	78 kg
Anchoring options	Surface ✓ In-ground ✓



The benches and tables can be combined in multiple settings by choosing individual products or assembled into larger solutions. See catalogue pages for more inspiration.

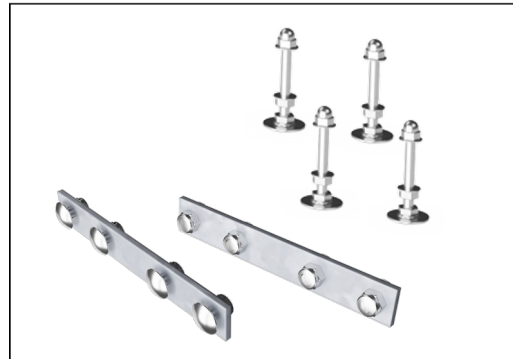

The hardware is made of stainless steel or galvanized steel to ensure durable connections with a high corrosion resistance.

Sustainability Data

PAR1404

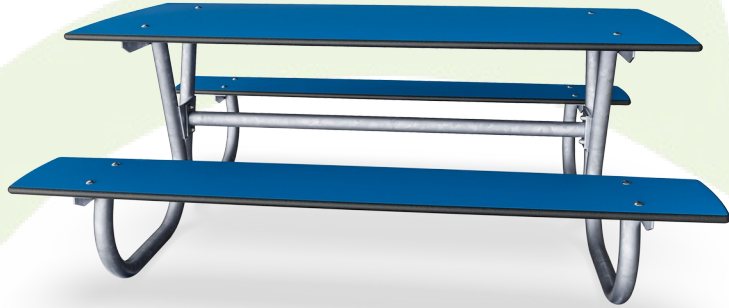

Cradle to Gate A1-A3	Total CO ₂ emission	CO ₂ e/kg	Recycled materials
	kg CO ₂ e	kg CO ₂ e/kg	%
PAR1404-0002	161.02	2.36	18.59

The overall framework applied for these factors is the Environmental Product Declaration (EPD), which quantifies "environmental information on the life cycle of a product and enable comparisons between products fulfilling the same function" (ISO, 2006). This follows the structure and applies a Life-Cycle Assessment approach to the entire Product stage from raw material through manufacturing (A1-A3))

Kompan A/S
C.F. Tietgens Boulevard 32C
DK-5220 Odense SØ
Denmark



Verification of CO₂ calculation of:
Park



Data version no. 2023-10-05

The CO₂ calculation and data are in compliance with the principles of a carbon footprint impact according to the GHG protocol (Greenhouse Gas Protocol), Scope 3, cradle to gate related to all individual components in the product category: "Park" represented by item no.: PAR4070-0001.

(Scope 3 emissions include emission sources in the upstream and downstream value chain).

Date: 30. October 2023 | Valid until: 30. October 2025

Verified by:

Julie Marie Vejsgaard Larsen, LCA & EPD Consultant

Verification based on report: Validation of CO₂ calculation of 9 categories of Kompan product line, version 1.0, prepared by: Bureau Veritas HSE, Denmark: Julie M. V. Larsen.

Publication date: 30. October 2023

By Bureau Veritas HSE
www.bureauveritas.dk
+45 7731 1000

