

Visboot & Winkel

PCM52531



Item nummer PCM52531-0901	
Algemene Product Informatie	
Afmetingen LxBxH	342x352x311 cm
Leeftijdsgroep	2+
Speelcapaciteit	13
Kleuropties	●



The countless play activities of the Cutter and Fish Shop play unit inspire children to play and imagine together, for long, again and again. The many explorative play features such as play panels with sounding gearing wheels, climb-through dense and the funnel leading to the treasure box all inspire countless dramatic play scenarios while stimulating them to

explore the many tactile, moving play features. The explorative and creative play from the wheels play panel intrigues children's creativity and builds their understanding of cause and effect. Often they spur make-believe play such as shop or cutter. This makes children play together, learn turn-taking and empathy and make friends.



Visboot & Winkel

PCM52531



Panelen van 19mm EcoCore™. EcoCore™ is een uiterst duurzaam, milieuvriendelijk materiaal. Het is recyclebaar na gebruik en gemaakt van +95% gerecycled post-consumer materiaal van voedselverpakkingsafval.



Main posts with hot dip galvanized steel footing are available in different materials: Pre-galvanized inside and outside with powder coated top finish steel posts. Lead free aluminum with color anodized top finish. TexMade posts of 95% post-consumer recycled PE and textile waste.



De stalen oppervlakken zijn van binnen en buiten thermisch verzinkt met loodvrij zink. Het verzinken heeft een uitstekende corrosiebestendigheid in de buitenlucht en vereist weinig onderhoud.



KOMPAN GreenLine uitvoeringen zijn gemaakt van uiterst milieuvriendelijke materialen met de laagst mogelijke CO2e emissiefactor. TexMade staanders, EcoCore™ panelen van 95% post-consumer gerecycled afval en gegoten PP platformen.

Item nummer PCM52531-0901

Installatie informatie

Max. valhoogte	40 cm
Veiligheidszone	28,4 m ²
Totale installatietijd	23,8
Graafwerk (vol.)	0,43 m ³
Benodigd beton	0,00 m ³
Verankeringsdiepte	90 cm
Verzendingsgewicht	733 kg
Verankeringsopties	Oppervlak ✓ In-ground ✓

Garantie informatie

EcoCore HDPE	Levenslang
Gegalvaniseerd staal	Levenslang
Bewegende delen	2 jaar
Staander	10 jaar
Gegarandeerde reserveonderdelen	10 jaar

Sustainability Data

PCM52531



Cradle to Gate A1-A3	Total CO ₂ emission	CO ₂ e/kg	Recycled materials
	kg CO ₂ e	kg CO ₂ e/kg	%
PCM52531-0901	694,10	1,37	78,85

The overall framework applied for these factors is the Environmental Product Declaration (EPD), which quantifies "environmental information on the life cycle of a product and enable comparisons between products fulfilling the same function" (ISO, 2006). This follows the structure and applies a Life-Cycle Assessment approach to the entire Product stage from raw material through manufacturing (A1-A3))

Kompan A/S
 C.F. Tietgens Boulevard 32C
 DK-5220 Odense SØ
 Denmark



Verification of CO₂ calculation of: Play systems



Data version no. 2023-10-05

The CO₂ calculation and data are in compliance with the principles of a carbon footprint impact according to the GHG protocol (Greenhouse Gas Protocol), Scope 3, cradle to gate related to all individual components in the product category: "Play systems" represented by item no.: PCM200321-0950.

(Scope 3 emissions include emission sources in the upstream and downstream value chain).

Date: 30. October 2023 | Valid until: 30. October 2025

Verified by:

Julie Marie Vejsgaard Larsen, LCA & EPD Consultant

Verification based on report: Validation of CO₂ calculation of 9 categories of Kompan product line, version 1.0, prepared by: Bureau Veritas HSE, Denmark: Julie M. V. Larsen.

Publication date: 30. October 2023

By Bureau Veritas HSE
 www.bureauveritas.dk
 +45 7731 1000



Max. valhoogte | Totale Hoogte | Veiligheidszone

Max. valhoogte | Totale Hoogte

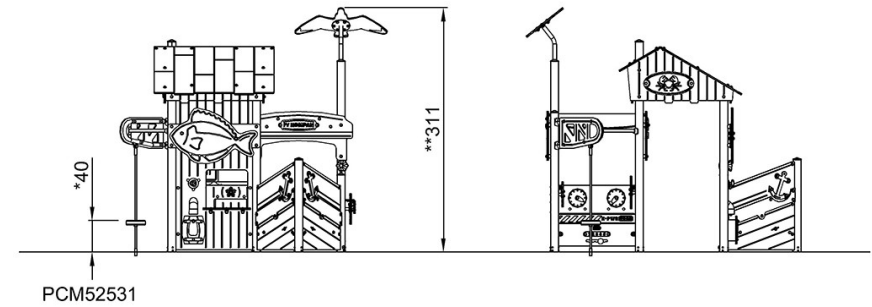
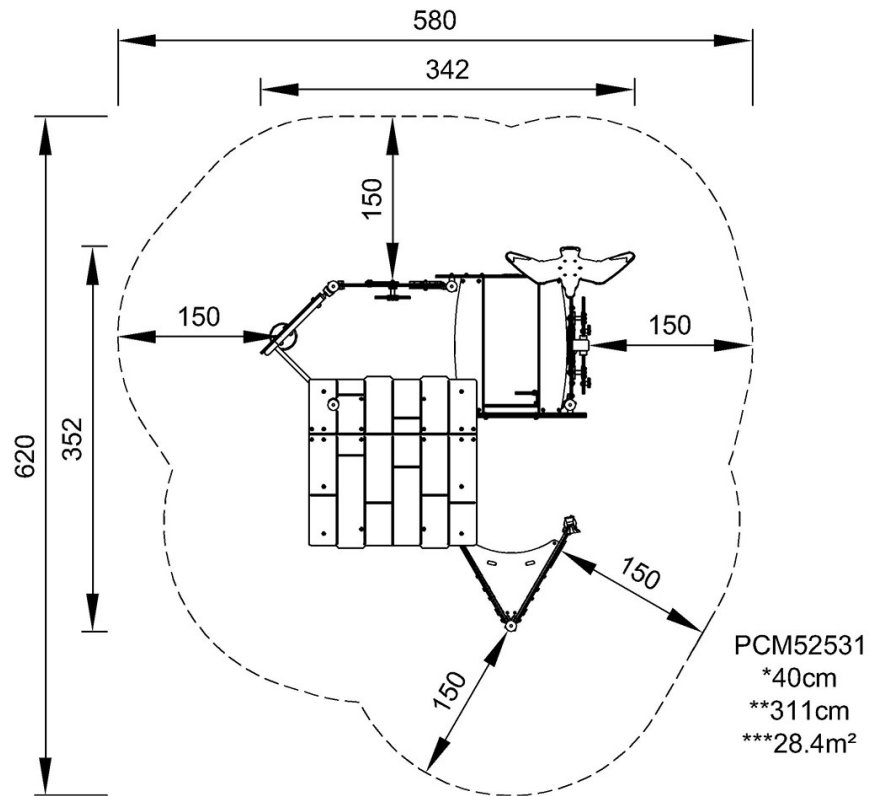

[Bekijk BOVENAANZICHT](#)

[Bekijk ZIJAAANZICHT](#)