

# Tlaky na ramena

FSW40300

**KOMPANI**



Položka č. FSW40300-0001

## Obecné informace o produktu

Rozměry DxŠxV	125x157x123 cm
Věková skupina	13+
Kapacita (uživatelé)	1
Možnosti barev	



S nastavitelnou zátěží umožňuje stroj Tlaky na ramena autentický silový trénink ramenních a tricepsových svalů. Uživatelsky přívětivé rukojeti s multifunkčními úchyty umožňují různé polohy při cvičení a dokonalou ergonomii pro uživatele jakékoli výšky. Stroj je konstruován s ohledem na bezpečnost; všechny mechanické pojistky jsou ukryty pod

krytem, aby se zabránilo riziku přimáčknutí.



# Tlaky na ramena

FSW40300

**KOMPAN**

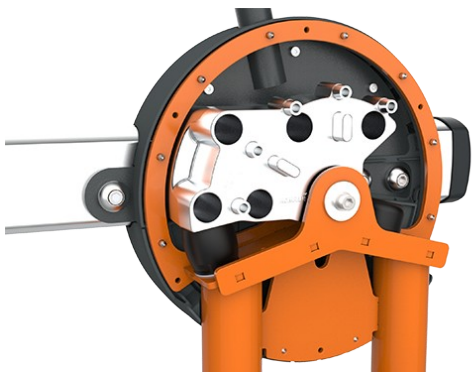

All mechanical stops are fully enclosed within the cover. The adjustable weight, featuring internal end stops and indexed positions, moves on rollers within an enclosed groove in an aluminium profile. As a result, entrapment is not possible, making it extremely safe to use and providing protection against the elements and unwanted abuse.



The weight on each side can be adjusted in 8 steps of 2,5 kg, providing a training weight from 5 to 40kg. The patent pending system is intuitive to use, eliminating the need for traditional pins that can get lost or stuck. Pull the handle and move the weight to quickly select the desired load.



The seat is made of blowmolded PE and mounted directly onto the steel frame, making it highly durable and resistant to wear and tear. To ensure comfort and a great user experience, the seat features an ergonomic groove. A seat height of 43 cm ensures easy access and transfer for wheelchair users.

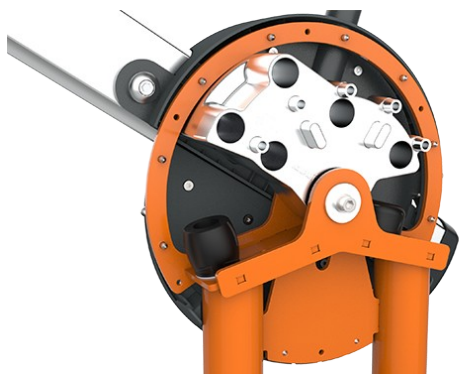

The machine features low operating noise thanks to an internal end stop made from TPE (thermoplastic elastomer). The damper absorbs impact energy from the weight with minimal rebound, reducing noise and vibration and ensuring a quieter, more controlled training experience.



**Handles**  
The ergonomically shaped handles feature multiple grip areas to support adaptable training. This allows users between 140–205 cm in height to perform exercises with correct ergonomics while enabling a wide variety of exercises that target different muscle groups. The handles are made from cast aluminium with a grip texture finish.



The unilateral movement design ensures that each arm works independently, preventing compensation by the stronger side. The independent movement also allows for greater flexibility, enabling multiple exercise variations and supporting inclusive training for users of different abilities.

Položka č. FSW40300-0001

## Informace o instalaci

Maximální výška pádu	43 cm
Bezpečnostní povrchová plocha	17,2 m <sup>2</sup>
Celková doba instalace	5,9 hodin
Objem výkopu	0,00 m <sup>3</sup>
Objem betonu	0,00 m <sup>3</sup>
Hloubka základu (standard)	0 cm
Hmotnost dodávky	308 kg
Možnosti ukotvení	

## Informace o záruce

Galvanizovaný/lakovaný kov	10 let
Hliník	15 let
Pohyblivé části	2 roky
Duté části z PE	10 let
Zaručené náhradní díly	10 let

**EN**  
**16630**  
compliant

# Data o Udržitelnosti

FSW40300

**KOMPAN**



## Independent review certificate

Kompan A/S  
C. F. Tietgens Blvd. 32C, 5220 Odense SØ

Bureau Veritas hereby attests that the CO<sub>2</sub>e-calculations (covering materials, processing, waste and transport) done by Kompan for "Fitness", meet the requirements set by the listed standard.

Kompan A/S uses a selection of EPDs and emission factors from the Life Cycle Assessment database Ecoinvent 3.11. These values are reported as kg CO<sub>2</sub>e, with all other impact categories excluded in line with the scope of ISO 14067:2018. The emission factors cover, material use, manufacturing processes, transport to Kompan, and electricity used during manufacturing. The presented emissions fall under GHG Protocol scope 3 emissions. Scope 1 and 2 are not presented. Scope 3 emissions include emission sources in the upstream value chain of a company, downstream emissions are excluded in this analysis.

Method: ISO 14067:2018 using GHG protocol guidance documents, reported as kg CO<sub>2</sub>e.

### Object

The verification has been done on the one pager "FAZ10100-0900" version: 27-10-2025. The supporting documentation "KOMPAN data\_updated emissions factors\_2025\_V2" and "Emissions factors, EPD's and ecoinvent 3.11\_2025" was also reviewed and approved.

### Declaration

The review has been completed as a critical review with a limited assurance. I hereby confirm that nothing has come to the reviewer's attention which would lead to conclude that the study does not give an accurate depiction or isn't completed following method of the CO<sub>2</sub>e calculation, the requirements of ISO 14067:2018, and 14071:2024, in the above referenced documentation.

**Note:** This verification only covers calculation elements according to method described in ISO 14067:2018 and may not be seen as a Life Cycle Assessment according to ISO 14067:2018.

**Ref.:** Kompan\_Verification report 2025, 28-10-2025

**Date of certificate:** 29-10-2025

**Expire date:** 29-10-2027

**Verified by:** Julie Marie Vejsgaard Larsen, Environmental Auditor

**Signature:**

Výrobní cyklus A1-A3	Celkové emise CO <sub>2</sub>	CO <sub>2</sub> e na kg	Recyklované materiály
	kg CO <sub>2</sub> e	kg CO <sub>2</sub> e/kg	%
<b>FSW40300-0001</b>	1.388,88	6,49	44,59

Celkovým rámcem uplatňovaným pro tyto faktory je Environmentální prohlášení o produktu (EPD), které kvantifikuje „environmentální informace o životním cyklu produktu a umožňuje srovnání mezi produkty, které plní stejnou funkci“ (ISO, 2006). Řídí se vnitřním uspořádáním a uplatňuje přístup k posuzování životního cyklu po celou fázi produktu od suroviny až po dokončení výroby (A1-A3).

# Tlaky na ramena

FSW40300

KOMPANĚ

\* Maximální výška pádu | \*\* Celková výška | \*\*\* Bezpečnostní povrchová plocha

\* Maximální výška pádu | \*\* Celková výška

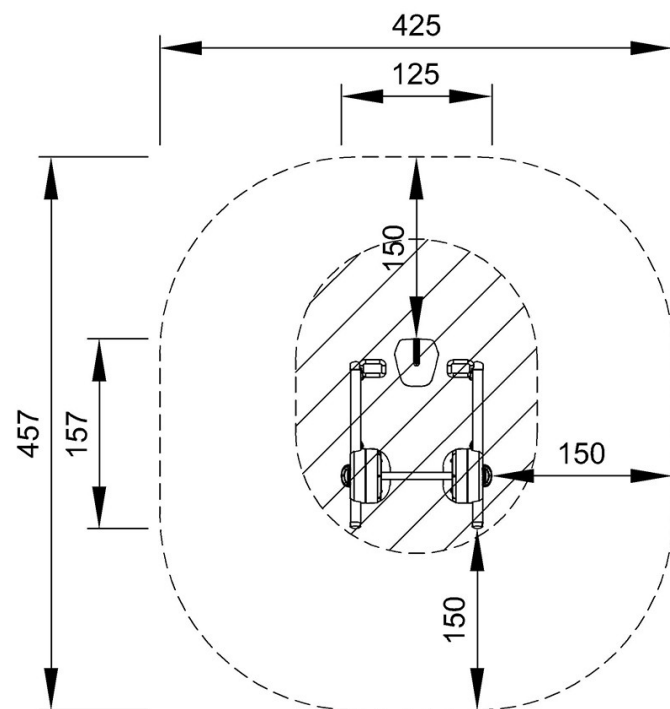

FSW40300  
\*43cm  
\*\*123cm  
\*\*\*17.2m<sup>2</sup>

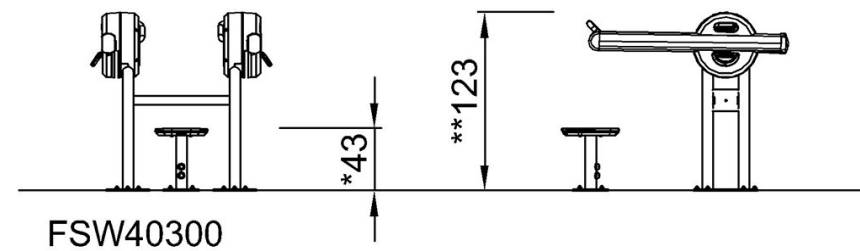

FSW40300

[Kliknutím zobrazíte poměr zobrazení POHLED SHORA](#)

[Kliknutím zobrazíte poměr stran BOČNÍ POHLED](#)