

Little Hen's House

NRO417

KOMPAN
Let's play



Item no. NRO417-1021

General Product Information

Dimensions LxWxH	294x413x281 cm
Age group	1+
Play capacity (users)	12
Color options	

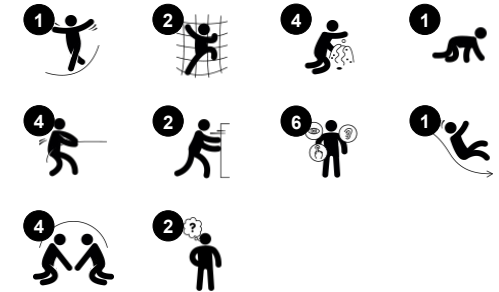

The Little Hen's House is a dense, activity packed ground level accessible play unit that offers a richness of home-themed play that will attract and excite toddlers again and again. Rich tactile features greatly increase play value and support emerging dramatic play in the toddlers. The scale of the Little Hen's House is perfectly shaped for toddlers. The desk adds to the overall playability of the house from the inside as well as the outside. The two-sided

play panel with yellow scoops that run in a grooves encourages play that stimulates theory of mind and logical thinking skills. The window with curtain invites social cooperation between inside and outside, supporting turn-taking and cooperation skills and not least inviting peek-a-boo games that support the understanding of object permanence: that things don't cease to exist when they are out of sight. Dramatic play supports language skills, and this units

welcomes the first try-outs of dramatic play with its many details and fun corners. Thrilling sliding is invited with a friendly loop between access platform and slide mouth. The inclined climbing wall on the other side adds varied access and supports cross-coordination which is key to physical as well as cognitive development at this age.



Data is subject to change without prior notice.

Little Hen's House

NRO417



All Organic Robinia products by KOMPAN are made of Robinia wood from sustainable European sources. On request it can be supplied as FSC® Certified (FSC® C004450).



The product/activities are preassembled from the factory to ensure all safety requirements are considered.



The paint used for coloured components is water based environmental friendly with excellent UV resistance. The paint is in compliance with EN 71 Part 3.

Item no. NRO417-1021

Installation Information

Max. fall height	100 cm
Safety surfacing area	30.2 m ²
Total installation time	20.6
Excavation volume	1.63 m ³
Concrete volume	0.00 m ³
Footing depth (standard)	100 cm
Shipment weight	887 kg
Anchoring options	In-ground ✓ Surface ✓

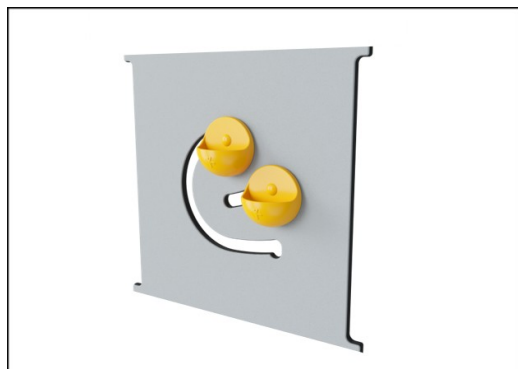

Panels of 19mm EcoCore™. EcoCore™ is a highly durable, eco friendly material, which is not only recyclable after use, but also consists of material produced from +95% recycled post consumer material from food packing waste.

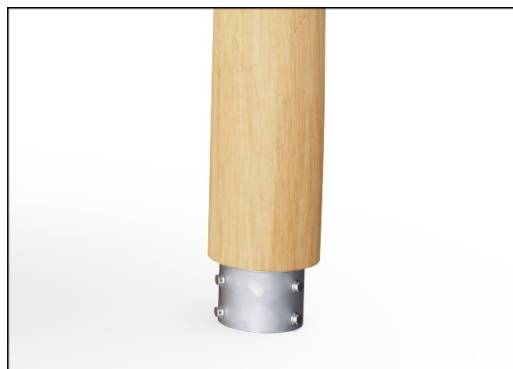

There are Multiple footing options for all products: Surface anchoring with steel footings and expansion bolts. Wood in-ground or steel in-ground footings.



Robinia products are available in three different wood treatment options: untreated Robinia wood or brown painted with a pigment that maintains the wood colour and coloured version with paint of selected components.



Sustainability Data

NRO417



Cradle to Gate A1-A3	Total CO ₂ emission	CO ₂ e/kg	Recycled materials
	kg CO ₂ e	kg CO ₂ e/kg	%
NRO417-1021	201.00	0.29	4.10

The overall framework applied for these factors is the Environmental Product Declaration (EPD), which quantifies "environmental information on the life cycle of a product and enable comparisons between products fulfilling the same function" (ISO, 2006). This follows the structure and applies a Life-Cycle Assessment approach to the entire Product stage from raw material through manufacturing (A1-A3))

Kompan A/S
 C.F. Tietgens Boulevard 32C
 DK-5220 Odense SØ
 Denmark



Verification of CO₂ calculation of: Nature play



Data version no. 2023-10-05

The CO₂ calculation and data are in compliance with the principles of a carbon footprint impact according to the GHG protocol (Greenhouse Gas Protocol), Scope 3, cradle to gate related to all individual components in the product category: "Nature play" represented by item no.: NRO409-0621.

(Scope 3 emissions include emission sources in the upstream and downstream value chain).

Date: 30. October 2023 | Valid until: 30. October 2025

Verified by:

Julie Marie Vejsgaard Larsen, LCA & EPD Consultant

Verification based on report: Validation of CO₂ calculation of 9 categories of Kompan product line, version 1.0, prepared by: Bureau Veritas HSE, Denmark: Julie M. V. Larsen.

Publication date: 30. October 2023

By Bureau Veritas HSE
 www.bureauveritas.dk
 +45 7731 1000



Little Hen's House

NRO417

* Max fall height | ** Total height | *** Safety surfacing area

* Max fall height | ** Total height

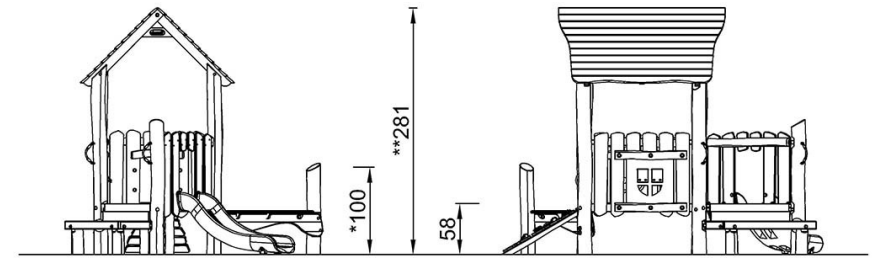
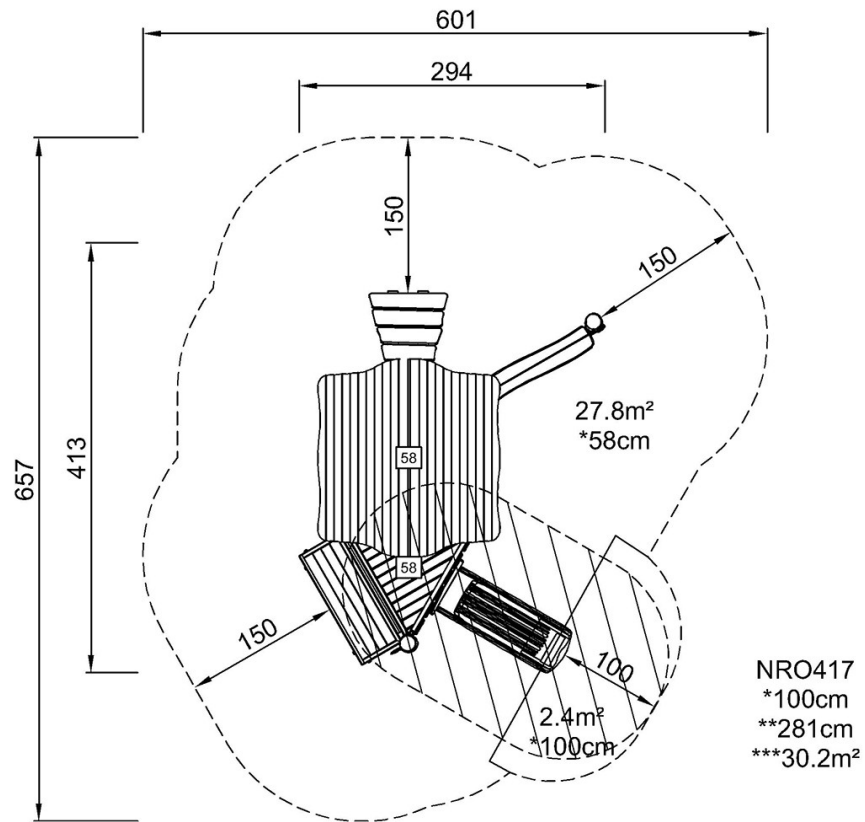

NRO417

[Click to see TOP VIEW](#)

[Click to see SIDE VIEW](#)