

Multi Goal, 10 ft

FRE2210

KOMPAN
Let's play



Item no. FRE2210-3317

General Product Information

Dimensions LxWxH	8'8"x10'7"x12'2"
Age group	3+
Play capacity (users)	-
Color options	●

The Wide Multigoal is a freestanding goal that incorporates panels and frames for use with other sports such as basketball, soccer, field hockey, and more.



Multi Goal, 10 ft

FRE2210



The goal measures ~140cm in depth and ~330cm in width, with all posts made of galvanized steel with a hot dip galvanized surface treatment. The front frame is made with Ø48 tubing, and the backside of the goal uses ten tubes with a diameter of ø38.

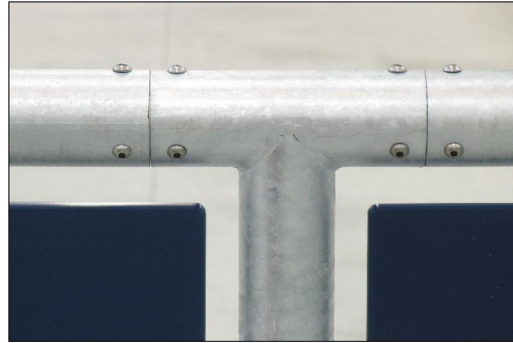

All steel components are manufactured from carbon steel, welding's according EN ISO 5817 & Hot dip galvanised (HDG) according to ISO1461. This process ensures good protection in all circumstances.

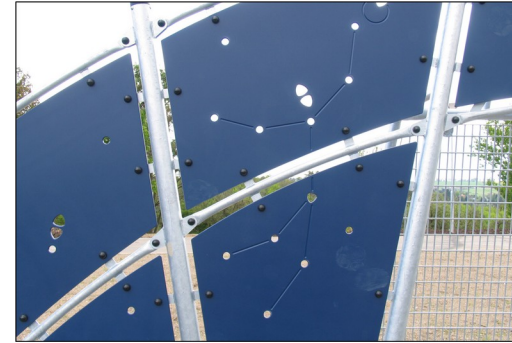

The HDPE panels are made with +95% recycled post-consumer material, e.g., food packing waste. Available in Night Sky Blue, with multiple other colors available to be requested. You can also request HDPE panels with patterns or logos engraved to increase the play value.



The basketball hoop is made from hot-dipped galvanized steel with a powder-coated finish, and the backboard is made from +95% PCR HDPE. The net is made from 100% nylon, with a circumference of ~Ø12.8in at the bottom and ~Ø19.7in at the top. The net can also be supplied with steel-reinforced PA net or steel chains.

Item no. FRE2210-3317

Installation Information

Max. fall height	0'0"
Safety surfacing area	0ft ²
Total installation time	8.9
Excavation volume	0.46yd ³
Concrete volume	0.44yd ³
Footing depth (standard)	1'8"
Shipment weight	1024lbs
Anchoring options	In-ground ✓ Surface ✓

Warranty Information

EcoCore HDPE	Lifetime
HDG post	Lifetime
Spare Parts Availability	10 Years

Sustainability Data

FRE2210



Cradle to Gate A1-A3	Total CO ₂ emission	CO ₂ e/kg	Recycled materials
	kg CO ₂ e	kg CO ₂ e/kg	%
FRE2210-3317	983.32	2.37	55.20

The overall framework applied for these factors is the Environmental Product Declaration (EPD), which quantifies "environmental information on the life cycle of a product and enable comparisons between products fulfilling the same function" (ISO, 2006). This follows the structure and applies a Life-Cycle Assessment approach to the entire Product stage from raw material through manufacturing (A1-A3)

Kompan A/S
 C.F. Tietgens Boulevard 32C
 DK-5220 Odense SØ
 Denmark

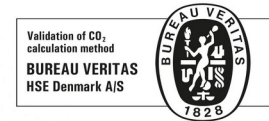

Verification of CO₂ calculation of: Sport



Data version no. 2023-10-05

The CO₂ calculation and data are in compliance with the principles of a carbon footprint impact according to the GHG protocol (Greenhouse Gas Protocol), Scope 3, cradle to gate related to all individual components in the product category: "Sport" represented by item no: FRE600202-0901.

(Scope 3 emissions include emission sources in the upstream and downstream value chain).

Date: 30. October 2023 | Valid until: 30. October 2025

Verified by:

Julie Marie Vejsgaard Larsen, LCA & EPD Consultant

Verification based on report: Validation of CO₂ calculation of 9 categories of Kompan product line, version 1.0, prepared by: Bureau Veritas HSE, Denmark: Julie M. V. Larsen.

Publication date: 30. October 2023

By Bureau Veritas HSE
 www.bureauveritas.dk
 +45 7731 1000



Multi Goal, 10 ft

FRE2210

* Max fall height | ** Total height | *** Safety surfacing area

* Max fall height | ** Total height

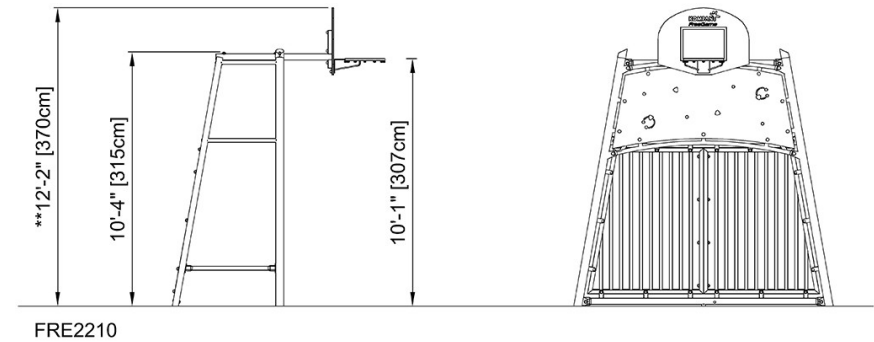
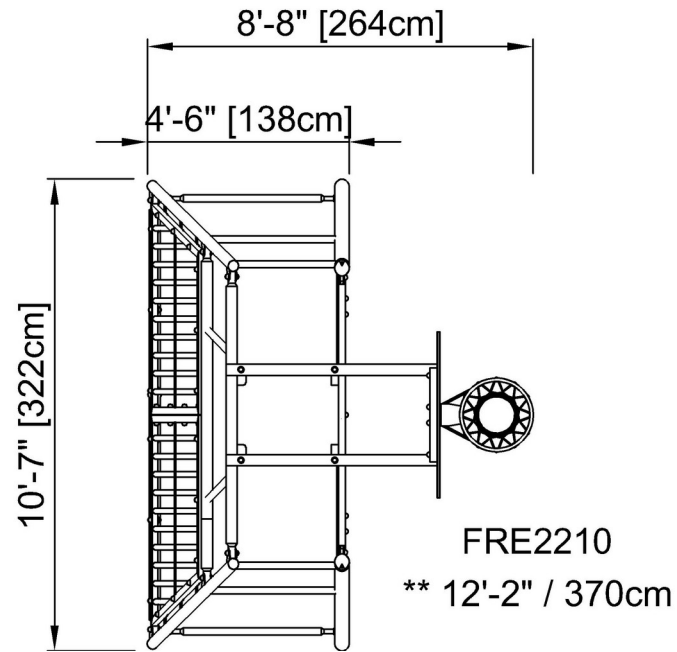

[Click to see TOP VIEW](#)

[Click to see SIDE VIEW](#)