

Oasis Creator

NRO531



Item no. NRO531-1021	
General Product Information	
Dimensions LxWxH	318x345x337 cm
Age group	2+
Play capacity (users)	16
Color options	



The Oasis Creator is an immensely attractive sand play unit that will absorb children in play for hours and hours. The crane is worked horizontally as well as vertically either by turning the grey plate or pulling the chain. The sand bucket will go up or down when pulling the chain. It will stay put when the chain is let go of. This, apart from providing fascinating

sand play, is a great training of children's logical thinking skills. The negotiation and cooperation to get sand to and from the sand table develops social-emotional skills. The sand table's sieve and tube lead sand away, training young children's understanding of object permanence: that things can still exist when out of sight. The sand wheel and shovel

adds a quieter sand play corner. The platforms are open and can be accessed in multiple ways, allowing for all users to play.



Oasis Creator

NRO531



Sand crane

Physical: hoisting the basket up and down trains arm muscles and dexterity. **Social-Emotional:** cooperating with others e.g. receiving the bucket trains cooperation skills. **Cognitive:** understanding the mechanism of the chains hoisting buckets up and down supports logical thinking skills. **Creative:** working with moveable play items that can leave a mark supports the child's creativity.



Supportive handholds

Physical: handhold provides good grip for less confident climbers. Pulling yourself up and in trains upper body muscles.



Sand desk with funnel

Social-Emotional: children can gather and store materials, cooperate and take a break together. **Cognitive:** sand can be shifted through the funnel, for understanding of cause and effect and object permanence: that materials don't vanish but run through at the other end.



Slope

Physical: inclined crawling or walking up or down develops the sense of balance and cross coordination. **Social-Emotional:** the inclination makes climbing feel secure, especially for younger children.

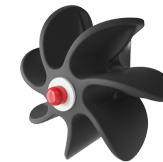

Sand wheel

Cognitive: the turning sand wheel stimulates cause and effect understanding.



Sand shovel

Physical: develops dexterity and upper body muscles. **Cognitive:** understanding of object permanence, emptying and filling scoop.

Oasis Creator

NRO531



All Organic Robinia products by KOMPAN are made of Robinia wood from sustainable European sources. On request it can be supplied as FSC® Certified (FSC® C004450).



The paint used for coloured components is water based environmentally friendly with excellent UV resistance. The paint is in compliance with EN 71 Part 3.



The Robinia products are designed with a KOMPAN colour concept with a number of different standard colours. The wood can also be supplied as untreated or with brown painted with a pigment that maintains the wood colour.



The product/activities are preassembled from the factory to ensure all safety requirements are considered.

Item no. NRO531-1021	
Installation Information	
Max. fall height	88 cm
Safety surfacing area	30.5 m ²
Total installation time	19.4
Excavation volume	0.45 m ³
Concrete volume	0.00 m ³
Footing depth (standard)	100 cm
Shipment weight	859 kg
Anchoring options	In-ground ✓
Warranty Information	
Robinia wood	15 years
Ropes & nets	10 years
Spare parts guaranteed	10 years
Stainless steel components	Lifetime
Stainless steel components	Lifetime



Sustainability Data

NRO531



Cradle to Gate A1-A3	Total CO ₂ emission	CO ₂ e/kg	Recycled materials
	kg CO ₂ e	kg CO ₂ e/kg	%
NRO531-1021	302.63	0.44	4.38

The overall framework applied for these factors is the Environmental Product Declaration (EPD), which quantifies "environmental information on the life cycle of a product and enable comparisons between products fulfilling the same function" (ISO, 2006). This follows the structure and applies a Life-Cycle Assessment approach to the entire Product stage from raw material through manufacturing (A1-A3))

Kompan A/S
 C.F. Tietgens Boulevard 32C
 DK-5220 Odense SØ
 Denmark



Verification of CO₂ calculation of: Nature play



Data version no. 2023-10-05

The CO₂ calculation and data are in compliance with the principles of a carbon footprint impact according to the GHG protocol (Greenhouse Gas Protocol), Scope 3, cradle to gate related to all individual components in the product category: "Nature play" represented by item no.: NRO409-0621.

(Scope 3 emissions include emission sources in the upstream and downstream value chain).

Date: 30. October 2023 | Valid until: 30. October 2025

Verified by:

Julie Marie Vejsgaard Larsen, LCA & EPD Consultant

Verification based on report: Validation of CO₂ calculation of 9 categories of Kompan product line, version 1.0, prepared by: Bureau Veritas HSE, Denmark: Julie M. V. Larsen.

Publication date: 30. October 2023

By Bureau Veritas HSE
 www.bureauveritas.dk
 +45 7731 1000



Oasis Creator

NRO531

* Max fall height | ** Total height | *** Safety surfacing area

* Max fall height | ** Total height

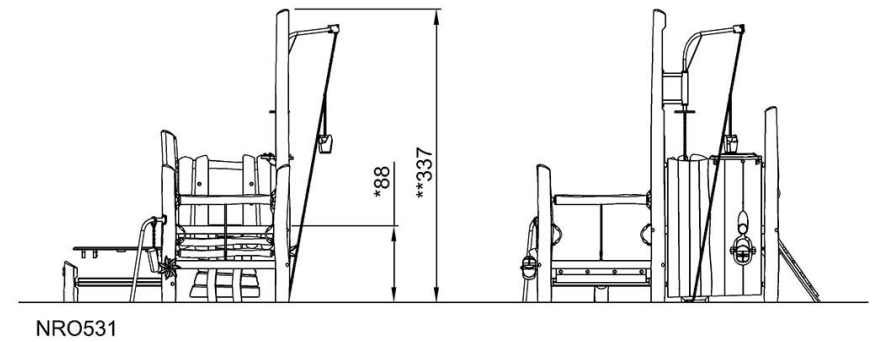
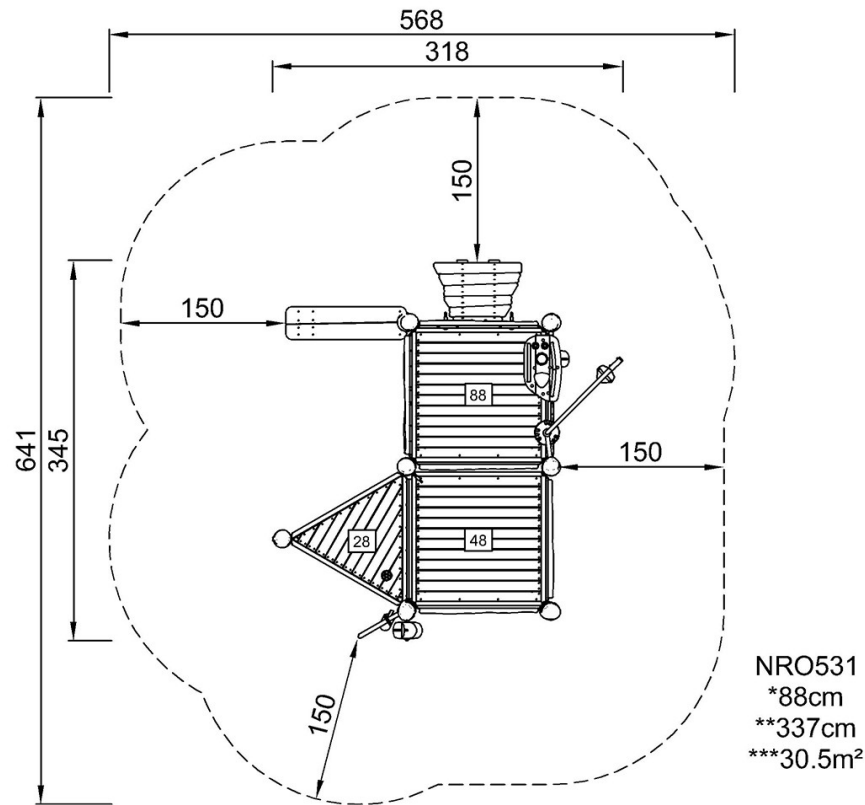

[Click to see TOP VIEW](#)

[Click to see SIDE VIEW](#)