

Double Car

MSC5414



Item no. MSC541421-3417P

General Product Information

Dimensions LxWxH	188x115x120 cm
Age group	6m - 4
Play capacity (users)	8
Colour options	

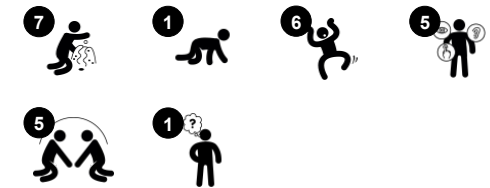

The Double Car attracts toddlers repeatedly with its friendly design. The familiar theme of driving opens a world of dramatic play, which intensely supports language and communication skills. Due to the transparency in design, adults can support play easily. The 360 design enables play both inside and outside the car and allows more children to

play together. The variety of play activities encourage exploration. All of the black parts of the Double Car can turn or move: the rubber doors open, the rear flaps can be pulled in different positions to vary the excitement of crawling through, the petrol flap and the wheels can be turned. So can the steering wheel and gear. The spoiler play sphere will create rattle

sounds when run in its groove. These play details support the child's logical thinking skills and play a huge role in cognitive development.

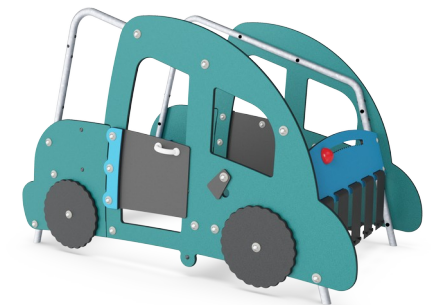

Double Car

MSC5414



Play sphere

Social-Emotional: can be played from both sides, encouraging cooperation. **Cognitive:** cause and effect understanding. **Creative:** leave a mark and place the spheres at different positions.

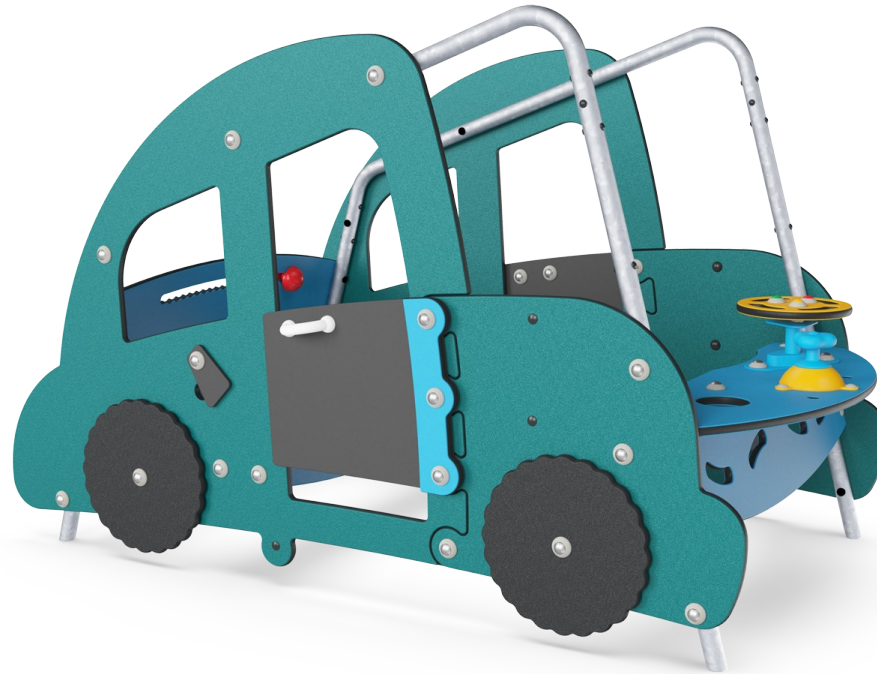

Flap door

Physical: tactile stimulation from leaning the body through rubber doors. **Cognitive:** suggests a theme and supports dramatic play, which stimulates language and communication skills.



Theme

Cognitive: suggests a theme and supports dramatic play, which stimulates language and communication skills.



Turning wheel

Social-Emotional: develops turn-taking, communication and cooperation. **Cognitive:** the manipulative item stimulates cause and effect understanding, logical thinking and communication. **Creative:** working with moveable play items that can leave a mark supports the child's creativity.



Gear shift

Social-Emotional: cooperation, turn-taking, sharing. **Cognitive:** suggests a theme and supports dramatic play, which stimulates language skills.

Double Car

MSC5414

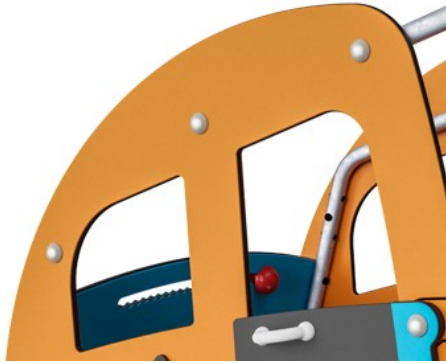

Panels of 19mm EcoCore™. EcoCore™ is a highly durable, eco friendly material, which is not only recyclable after use, but also consists of material produced from +95% recycled post consumer material from food packing waste.



The steel surfaces are hot dip galvanised inside and outside with lead free zinc. The galvanisation has excellent corrosion resistance in outside environments and requires low maintenance.



Membranes consist of friction-proof rubberized material of conveyor belt quality with excellent UV resistance. Embedded is a four-layered armouring made of woven polyester. The armouring and the two surface layers result in a total thickness of 7 mm.

Item no. MSC541421-3417P

Installation Information

Max. fall height	0 cm
Safety surfacing area	0.0 m ²
Total installation time	7.5
Excavation volume	0.22 m ³
Concrete volume	0.00 m ³
Footing depth (standard)	60 cm
Shipment weight	144 kg
Anchoring options	In-ground ✓ Surface ✓

Warranty Information

EcoCore HDPE	Lifetime
Hot dip galvanised steel	Lifetime
Membrane	2 years
Movable parts	2 years
Spare parts guaranteed	10 years

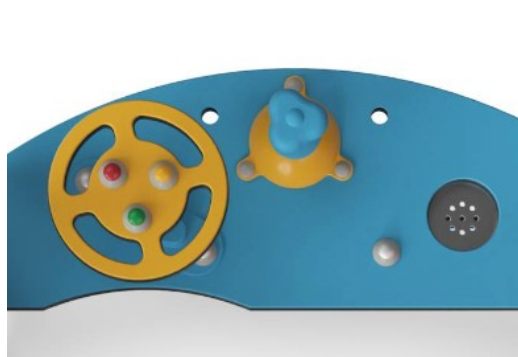

Gear shift is made of PP. PP has good wearing and impact resistance.

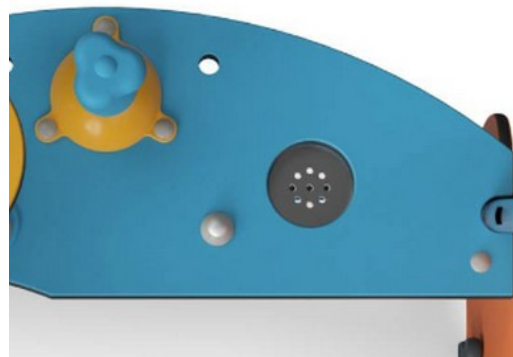

Sand strainer is made of high-quality stainless steel to ensure durability of the product.



KOMPAN GreenLine versions are designed with ultimate environmentally friendly materials with lowest possible CO2e emission factor such as EcoCore™ panels of +95% post consumer recycled ocean waste.

Elevated activities 0	Accessible elevated activities	Accessible ground level activities	Accessible ground level play types
Present	0	1	1
Required	0	1	1



Sustainability Data

MSC5414

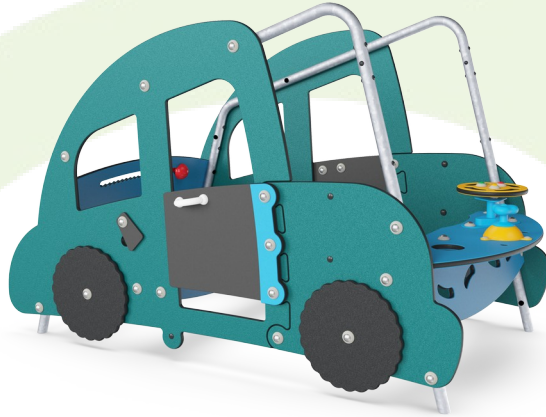

Cradle to Gate A1-A3	Total CO ₂ emission	CO ₂ e/kg	Recycled materials
	kg CO ₂ e	kg CO ₂ e/kg	%
MSC541421-3417P	140.93	1.55	76.57

The overall framework applied for these factors is the Environmental Product Declaration (EPD), which quantifies "environmental information on the life cycle of a product and enable comparisons between products fulfilling the same function" (ISO, 2006). This follows the structure and applies a Life-Cycle Assessment approach to the entire Product stage from raw material through manufacturing (A1-A3))

Kompan A/S
 C.F. Tietgens Boulevard 32C
 DK-5220 Odense SØ
 Denmark



Verification of CO₂ calculation of: Themed play systems



Data version no. 2023-10-05

The CO₂ calculation and data are in compliance with the principles of a carbon footprint impact according to the GHG protocol (Greenhouse Gas Protocol), Scope 3, cradle to gate related to all individual components in the product category: "Themed play systems" represented by item no.: MSC641100-3717P.

(Scope 3 emissions include emission sources in the upstream and downstream value chain).

Date: 30. October 2023 | Valid until: 30. October 2025

Verified by:

Julie Marie Vejsgaard Larsen, LCA & EPD Consultant

Verification based on report: Validation of CO₂ calculation of 9 categories of Kompan product line, version 1.0, prepared by: Bureau Veritas HSE, Denmark: Julie M. V. Larsen.

Publication date: 30. October 2023

By Bureau Veritas HSE
 www.bureauveritas.dk
 +45 7731 1000



Double Car

MSC5414

* Max fall height | ** Total height | *** Safety surfacing area

* Max fall height | ** Total height

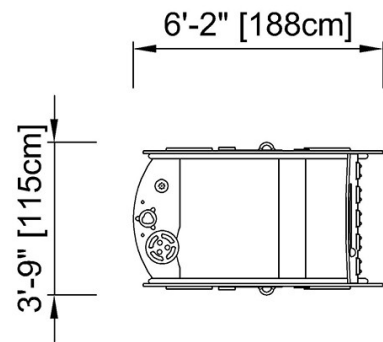

MSC541401

**3'-11" / 120cm

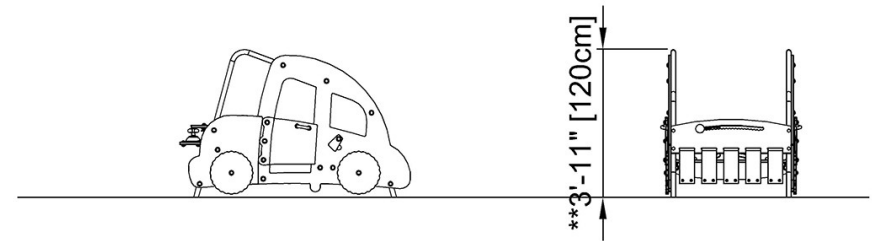

MSC541401

[Click to see TOP VIEW](#)

[Click to see SIDE VIEW](#)