

Village House

NRO405



Item no. NRO405-0621

General Product Information

Dimensions LxWxH	262x182x287 cm
Age group	2+
Play capacity (users)	8
Color options	



The Village house evokes the play urge in all children with its curved roof and a nice desk and bench inside. They will come back for more play again and again. The dramatic play scenarios of the house know no limits: there is room for continued role play that children will return to again and again. The desk and bench inside will stimulate breaks and function as

table, too. The stair and slope in and out the house makes varied accesses that stimulate both crawling and climbing. This trains cross-coordination, that is fundamental to the ability to e.g. read. When children do dramatic play, they play out an understanding of everyday scenarios negotiating through their life observations. While doing so, they constantly

talk and communicate with their peers, thus hugely stimulating language skills and thinking skills.



Village House

NRO405



All Organic Robinia products by KOMPAN are made of Robinia wood from sustainable European sources. On request it can be supplied as FSC® Certified (FSC® C004450).



The paint used for coloured components is water based environmentally friendly with excellent UV resistance. The paint is in compliance with EN 71 Part 3.



The Robinia products are designed with a KOMPAN colour concept with a number of different standard colours. The wood can also be supplied as untreated or with brown painted with a pigment that maintains the wood colour.

Item no. NRO405-0621

Installation Information

Max. fall height	48 cm
Safety surfacing area	22.4 m ²
Total installation time	15.5
Excavation volume	0.46 m ³
Concrete volume	0.00 m ³
Footing depth (standard)	60 cm
Shipment weight	740 kg
Anchoring options	In-ground ✓ Surface ✓

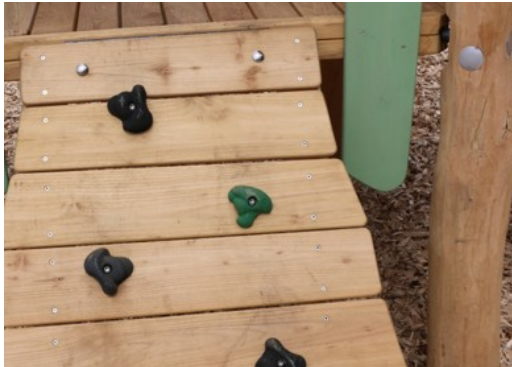

The product/activities are preassembled from the factory to ensure all safety requirements are considered.



The hardware is made of stainless steel or galvanised steel to ensure durable connections with a high corrosion resistance.



Sustainability Data

NRO405



Cradle to Gate A1-A3	Total CO ₂ emission	CO ₂ e/kg	Recycled materials
	kg CO ₂ e	kg CO ₂ e/kg	%
NRO405-0621	155.80	0.25	1.80

The overall framework applied for these factors is the Environmental Product Declaration (EPD), which quantifies "environmental information on the life cycle of a product and enable comparisons between products fulfilling the same function" (ISO, 2006). This follows the structure and applies a Life-Cycle Assessment approach to the entire Product stage from raw material through manufacturing (A1-A3))

Kompan A/S
 C.F. Tietgens Boulevard 32C
 DK-5220 Odense SØ
 Denmark



Verification of CO₂ calculation of: Nature play



Data version no. 2023-10-05

The CO₂ calculation and data are in compliance with the principles of a carbon footprint impact according to the GHG protocol (Greenhouse Gas Protocol), Scope 3, cradle to gate related to all individual components in the product category: "Nature play" represented by item no.: NRO409-0621.

(Scope 3 emissions include emission sources in the upstream and downstream value chain).

Date: 30. October 2023 | Valid until: 30. October 2025

Verified by:

Julie Marie Vejsgaard Larsen, LCA & EPD Consultant

Verification based on report: Validation of CO₂ calculation of 9 categories of Kompan product line, version 1.0, prepared by: Bureau Veritas HSE, Denmark: Julie M. V. Larsen.

Publication date: 30. October 2023

By Bureau Veritas HSE
 www.bureauveritas.dk
 +45 7731 1000



Village House

NRO405

* Max fall height | ** Total height | *** Safety surfacing area

* Max fall height | ** Total height

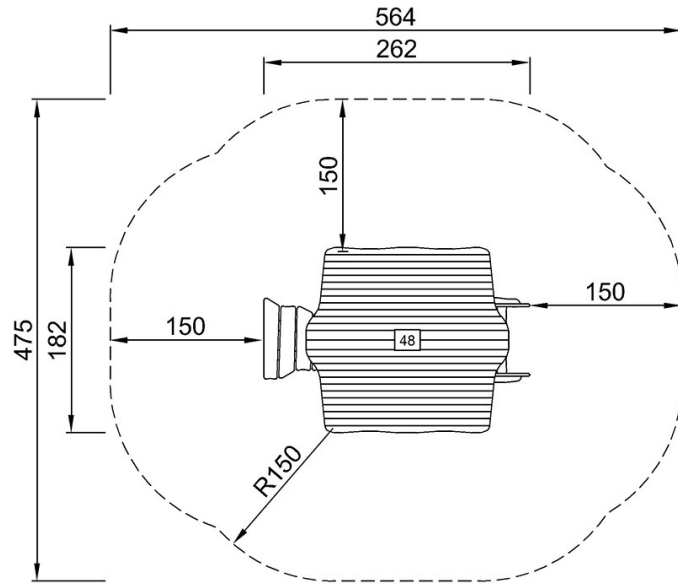

NRO405-xx21
*48cm
**287cm
***22.4m²

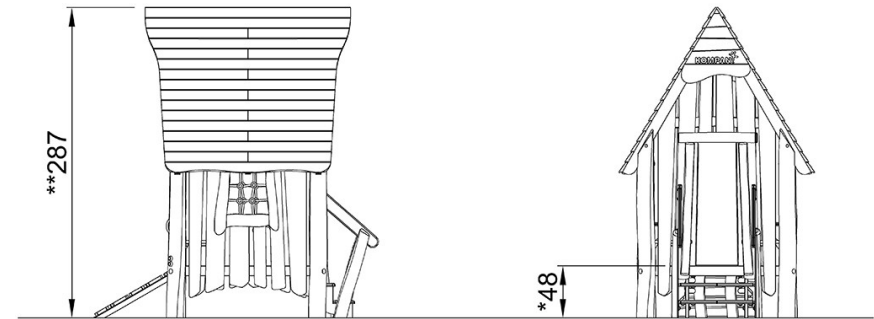

NRO405

[Click to see TOP VIEW](#)

[Click to see SIDE VIEW](#)