

# Shoulder Press

FSW40301



Item no. FSW40301-0001	
<b>General Product Information</b>	
Dimensions LxWxH	4'1"x5'2"x4'0"
Age group	13+
Capacity (users)	1
Color options	



Featuring an adjustable load, the Shoulder Press provides authentic weight training for the shoulder and triceps muscles. The user-friendly handles with multi-function grips allow for various exercise positions and perfect ergonomics for users of all heights. The Shoulder Press is built for safety, with all mechanical stops enclosed within the cover to

ensure there are no crush points.

# Shoulder Press

FSW40301



All mechanical stops are fully enclosed within the cover. The adjustable weight, featuring internal end stops and indexed positions, moves on rollers within an enclosed groove in an aluminum profile. As a result, entrapment is not possible, making it extremely safe to use and providing protection against the elements and unwanted abuse.



The machine features low operating noise thanks to an internal end stop made from TPE (thermoplastic elastomer). The damper absorbs impact energy from the weight with minimal rebound, reducing noise and vibration and ensuring a quieter, more controlled training experience.



The unilateral movement design ensures that each arm works independently, preventing compensation by the stronger side. The independent movement also allows for greater flexibility, enabling multiple exercise variations and supporting inclusive training for users of different abilities.

Item no. FSW40301-0001	
Installation Information	
Max. fall height	1'5"
Safety surfacing area	103ft <sup>2</sup>
Total installation time	5.9 hours
Excavation volume	0yd <sup>3</sup>
Concrete volume	0yd <sup>3</sup>
Footing depth (standard)	0'0"
Shipment weight	631lbs
Anchoring options	
Warranty Information	
Galvanized/painted metal	10 Years
Aluminum	15 Years
Movable parts	2 Years
Hollow PE Parts	10 Years
Spare Parts Availability	10 Years



The weight on each side can be adjusted in 8 steps of 5.5 lbs, providing a training weight from 15 to 85 lbs. The patent pending system is intuitive to use, eliminating the need for traditional pins that can get lost or stuck. Pull the handle and move the weight to quickly select the desired load.



The seat is made of blow-molded PE and mounted directly onto the steel frame, making it highly durable and resistant to wear and tear. To ensure comfort and a great user experience, the seat features an ergonomic groove. A seat height of 16.9" ensures easy access and transfer for wheelchair users.



The seat is made of blow-molded PE and mounted directly onto the steel frame, making it highly durable and resistant to wear and tear. To ensure comfort and a great user experience, the seat features an ergonomic groove. A seat height of 16.9" ensures easy access and transfer for wheelchair users.

**ASTM  
F3101  
compliant**

# Sustainability Data

FSW40301



Cradle to Gate A1-A3	Total CO <sub>2</sub> emission	CO <sub>2</sub> e/kg	Recycled material
	kg CO <sub>2</sub> e	kg CO <sub>2</sub> e/kg	%
<b>FSW40301-0001</b>	1,388.88	6.49	44.59

The overall framework applied for these factors is the Environmental Product Declaration (EPD), which quantifies "environmental information on the life cycle of a product and enable comparisons between products fulfilling the same function" (ISO, 2006). This follows the structure and applies a Life-Cycle Assessment approach to the entire Product stage from raw material through manufacturing (A1-A3))



## Independent review certificate

Kompan A/S  
C. F. Tietgens Blvd. 32C, 5220 Odense SØ

Bureau Veritas hereby attests that the CO<sub>2</sub>e-calculations (covering materials, processing, waste and transport) done by Kompan for "Fitness", meet the requirements set by the listed standard.

Kompan A/S uses a selection of EPDs and emission factors from the Life Cycle Assessment database Ecoinvent 3.11. These values are reported as kg CO<sub>2</sub>e, with all other impact categories excluded in line with the scope of ISO 14067:2018. The emission factors cover, material use, manufacturing processes, transport to Kompan, and electricity used during manufacturing. The presented emissions fall under GHG Protocol scope 3 emissions. Scope 1 and 2 are not presented. Scope 3 emissions include emission sources in the upstream value chain of a company, downstream emissions are excluded in this analysis.

Method: ISO 14067:2018 using GHG protocol guidance documents, reported as kg CO<sub>2</sub>e.

### Object

The verification has been done on the one pager "FAZ10100-0900" version: 27-10-2025. The supporting documentation "KOMPAN data\_updated emissions factors\_2025\_V2" and "Emissions factors, EPD's and ecoinvent 3.11\_2025" was also reviewed and approved.

### Declaration

The review has been completed as a critical review with a limited assurance. I hereby confirm that nothing has come to the reviewer's attention which would lead to conclude that the study does not give an accurate depiction or isn't completed following method of the CO<sub>2</sub>e calculation, the requirements of ISO 14067:2018, and 14071:2024, in the above referenced documentation.

**Note:** This verification only covers calculation elements according to method described in ISO 14067:2018 and may not be seen as a Life Cycle Assessment according to ISO 14067:2018.

**Ref.:** Kompan\_Verification report 2025, 28-10-2025

**Date of certificate:** 29-10-2025

**Expire date:** 29-10-2027

**Verified by:** Julie Marie Vejsgaard Larsen, Environmental Auditor

**Signature:**

# Shoulder Press

FSW40301

\* Max fall height | \*\* Total height | \*\*\* Safety surfacing area

\* Max fall height | \*\* Total height

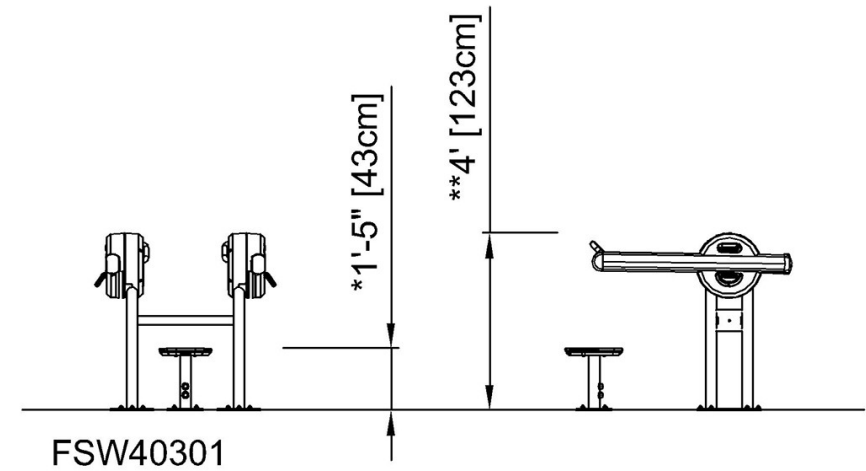
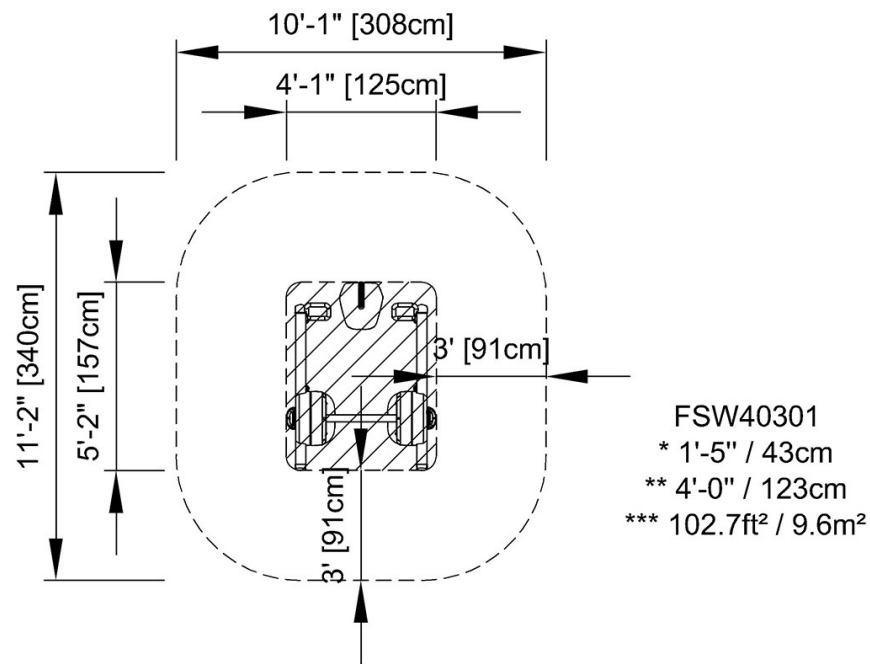

[Click to see TOP VIEW](#)

[Click to see SIDE VIEW](#)