

Supernova

GXY916

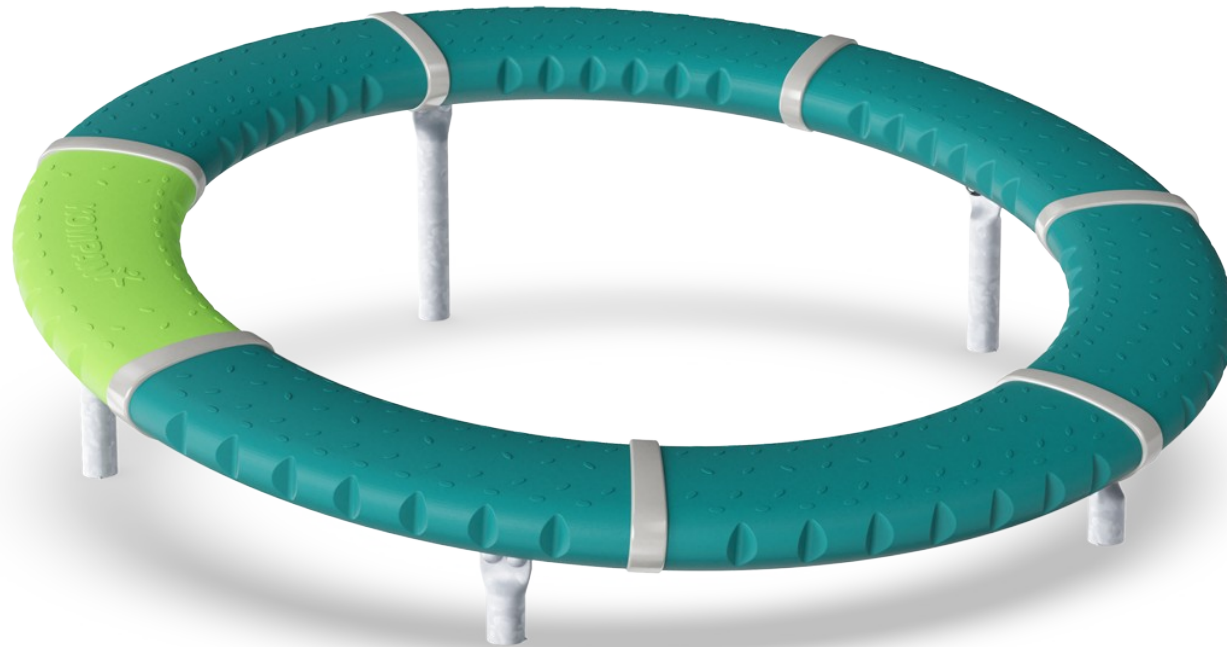

Item no. GXY916021-3417

General Product Information

Dimensions LxWxH	206x206x60 cm
Age group	6+
Play capacity (users)	8
Colour options	

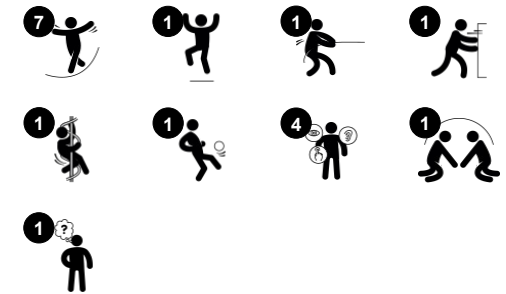

The large, slanting, rotating ring with 7 divided areas invite children to explore the Supernova's countless play options, turning, spinning and balancing either seated, lying, standing, alone or with friends. The many play opportunities and the open ground level design makes it possible for all abilities to be included in play. The 7 areas of the ring inspire a multitude of

different games-with-rules, rough-and-tumble play can be explored and the pushing of the ring and running help develop the children's arm and leg muscles and cardio. The jumping on and off the rotating ring builds bone density. The Supernova trains the sense of balance and space, crucial in being able to sit still or navigate traffic safely. Children help one

another and invent games these stimulate the child's social-emotional skills and cognition, empathy, cooperation skills and logical thinking.



Supernova

GXY916



Slanting ring

Physical: the inclination develops the sense of balance and muscle strength when walking upwards or pushing the ring into motion. Bone density is built when jumping on and off. Furthermore the cardio gets used when pushing, running. The grooves support grip.
Social-Emotional: the round shape allows assistance all over.

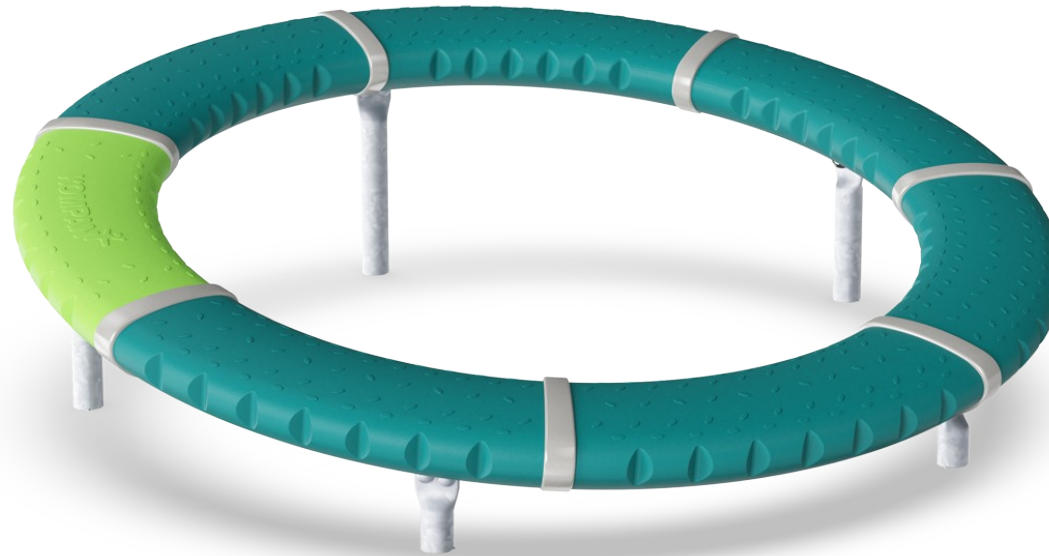

Rotation and gravity

Physical: balance and coordination is used to stay on the ring in motion and walking up- or downwards. This also trains leg and core muscles. **Social-Emotional:** cooperation setting the ring in motion. The round shape allows assistance from all sides. **Cognitive:** logical thinking, working with gravity when figuring out how to stay on the ring or make it move faster.



7 departments/rings

Social-Emotional: turn-taking and cooperation when finding new games. One different colored part makes it possible to count rounds when running, encouraging positive competition. The division into ring sections designates personal space for users who need that. **Cognitive:** games-with-rules gets invented, which promotes logical thinking.

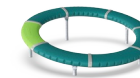

Low entry

Social-Emotional: accessible and usable for all abilities and a wide age span.

Supernova

GXY916



The Supernova is a unique carousel with no centre point placed in an angle of 10° which makes it turn when children walks the ring. The outside ring diameter is 208cm and the upper point is 60cm above ground level.



The 7 ring segments are made of low density PE made from 33% post-consumer recycled materials with excellent impact strength and usable within a large temperature span. Each segment has integrated handholds on both sides and non-skid top surface for safe usage.



The Supernova is designed with a lifetime lubricated maintenance free roller system of vertical and horizontal rollers. The roller system is fully closed and sealed by two rubber lists.

Item no. GXY916021-3417	
Installation Information	
Max. fall height	100 cm
Safety surfacing area	28.9 m ²
Total installation time	3.0
Excavation volume	0.21 m ³
Concrete volume	0.05 m ³
Footing depth (standard)	60 cm
Shipment weight	277 kg
Anchoring options	In-ground ✓ Surface ✓
Warranty Information	
Connector brackets	10 years
Hollow PE parts	10 years
Hot dip galvanised steel	Lifetime
Roller system	5 years
Spare parts guaranteed	10 years



The Supernova is designed with 5 legs with hot dip galvanised surfacing treatment. The galvanisation has excellent corrosion resistance in outside environments and requires low maintenance.



The sand colored variant is made of rotomolded stone mixed PE made from 33% post consumer materials with a non skid surface texture. Minor differences in the stone mix visuality of the material are to be expected.



GreenLine versions in teal color are designed with molded PE parts which consist of 33% recycled post-consumer ocean waste. Ocean waste is collected from the maritime industry, such as fishing nets, ropes and trawls.



Sustainability Data

GXY916

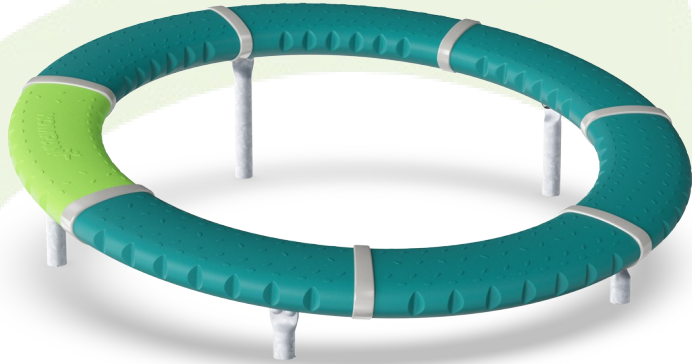

Cradle to Gate A1-A3	Total CO ₂ emission	CO ₂ e/kg	Recycled materials
	kg CO ₂ e	kg CO ₂ e/kg	%
GXY916021-3417	422.96	2.82	44.65

The overall framework applied for these factors is the Environmental Product Declaration (EPD), which quantifies "environmental information on the life cycle of a product and enable comparisons between products fulfilling the same function" (ISO, 2006). This follows the structure and applies a Life-Cycle Assessment approach to the entire Product stage from raw material through manufacturing (A1-A3))

Kompan A/S
C.F. Tietgens Boulevard 32C
DK-5220 Odense SØ
Denmark



Verification of CO₂ calculation of: Freestanding play equipment



Data version no. 2023-10-05

The CO₂ calculation and data are in compliance with the principles of a carbon footprint impact according to the GHG protocol (Greenhouse Gas Protocol), Scope 3, cradle to gate related to all individual components in the product category: "Freestanding play equipment" represented by item no.: GXY916012-3417.

(Scope 3 emissions include emission sources in the upstream and downstream value chain).

Date: 30. October 2023 | Valid until: 30. October 2025

Verified by:

Julie Marie Vejsgaard Larsen, LCA & EPD Consultant

Verification based on report: Validation of CO₂ calculation of 9 categories of Kompan product line, version 1.0, prepared by: Bureau Veritas HSE, Denmark: Julie M. V. Larsen.

Publication date: 30. October 2023

By Bureau Veritas HSE
www.bureauveritas.dk
+45 7731 1000



Supernova

GXY916

* Max fall height | ** Total height | *** Safety surfacing area

* Max fall height | ** Total height

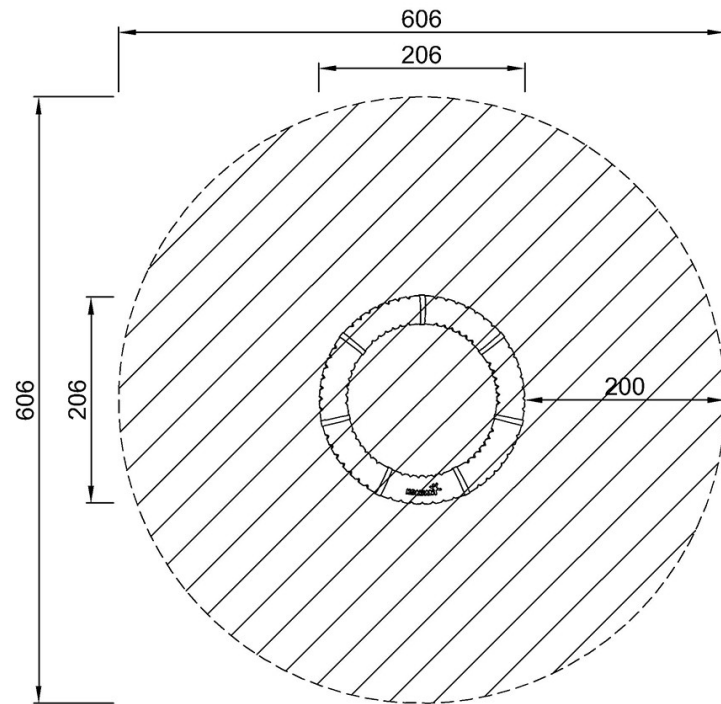

GXY916021
*100cm
**60cm
***28.9m²

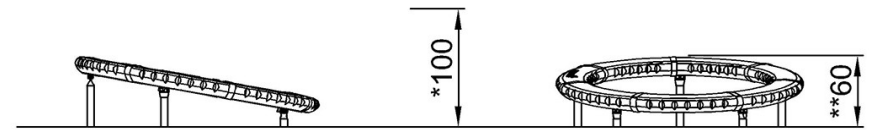

GXY916021

[Click to see TOP VIEW](#)

[Click to see SIDE VIEW](#)